

4

3

2

1

THIS DRAWING IS UNPUBLISHED. RELEASED FOR PUBLICATION .19 . . .
 © COPYRIGHT 19 BY AMP INCORPORATED. ALL RIGHTS RESERVED.

LOC	DIST	REVISIONS					
		P	LTR	DESCRIPTION	DATE	DWN	APVD
G	14	G		ADDED -21 PER 0G3A-0273-00	22MAY00	JR	MS

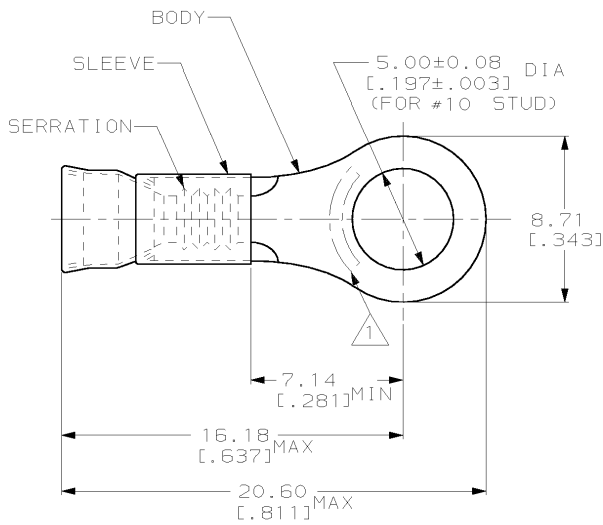

△ 1 STAMP AMP 16-14* APPROX AS SHOWN

- 2. WIRE INSUL DIA, 3.05-4.32 [0.120-.170]
- 3. TONGUE MATL THK, 0.79±0.05 [0.031±0.002]

△ PRELIMINARY - NOT FOR PRODUCTION

QTY	PACKAGE TYPE	PART NO
5000	ON TAPE, REEL	2-322375-1
1000	LOOSE PIECE	322375

AMP INCORPORATED CUSTOMER SERVICE SYSTEM		MAX RECOMMENDED OPERATING TEMPERATURE: 343°C [650°F]	THIS DRAWING IS A CONTROLLED DOCUMENT FOR AMP INCORPORATED. IT IS SUBJECT TO CHANGE AND THE CONTROLLING ENGINEERING ORGANIZATION SHOULD BE CONTACTED FOR THE LATEST REVISION.		DWN L OLMEDA 100CT94	AMP AMP Incorporated Harrisburg, PA 17105-3608	
FOR ADDITIONAL PRODUCT INFORMATION OR COPIES OF DRAWINGS AND TECHNICAL DOCUMENTS	PRODUCT INFORMATION CENTER 1-800-522-6752	VOLTAGE RATING: -	DIMENSIONS: mm [in]	TOLERANCES UNLESS OTHERWISE SPECIFIED: 0 PLC ±- 1 PLC ±- 2 PLC ±0.20 [0.008] 3 PLC ±- 4 PLC ±- ANGLES ±-	CHK M ELLIS 100CT94		NAME S BORTNER 100CT94
FOR APPLICATION TOOLING INFORMATION	TOOLING ASSISTANCE CENTER 1-800-722-1111	CIRCULAR MIL AREA: 1.04mm ² -2.62mm ² [2050-5180]	MATERIAL: BODY, CU PER ASTM B152 SLEEVE, NI SIL PER ASTM B122		FINISH: BODY, NP, 00-N-290	PRODUCT SPEC -	TERMINAL, RING TONGUE, STRATOTHERM, DIAMOND GRIP, WIRE SIZE, 16-14 AWG
FOR ORDER ENTRY	1-800-526-5142	STRANDED WIRE	MATERIAL: BODY, CU PER ASTM B152 SLEEVE, NI SIL PER ASTM B122		FINISH: BODY, NP, 00-N-290	APPLICATION SPEC -	SIZE A3
AMP 1476-19 REV 09MAY94			CUSTOMER DRAWING		WEIGHT -	DRAWING NO C-322375	SCALE 6:1
27 OCT 1994 09:37:24 AMP12368 <UUI28A>DEPT1132-U.DWG1132-U.REV-U.DIAMOND-GRIP-U.STRATOTHERM-U.CUST						SHEET 1 OF 1	REV 6