

THE DRAWING IS UNPUBLISHED. RELEASED FOR PUBLICATION. ALL RIGHTS RESERVED.

REV	DATE	DESCRIPTION	MS	DATE	BY	APPD
G1		REVISED PER ECO-11-004820		11MAR11	RK	HMR

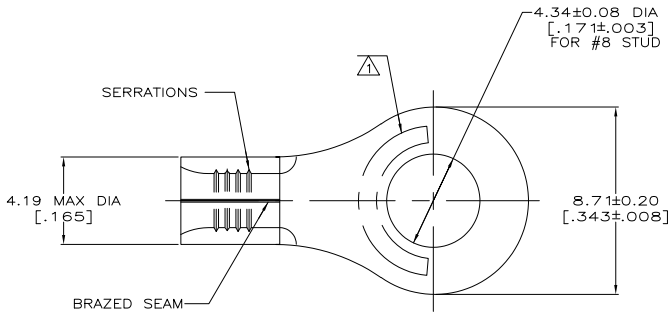

AMP WIRE RANGE	E13288 Listed
16-14 AWG SOLID OR STRANDED	16-14 AWG SOLID OR STRANDED
LR7189 Certified	MILITARY P/N AND CLASS
16-14 AWG SOLID OR STRANDED	NOT APPLICABLE

- △ STAMP AMP 16-14* APPROX AS SHOWN
- △ 0.00254 [.000100] MIN TIN PER ASTM B-545.
- △ CLEANED, UNPLATED

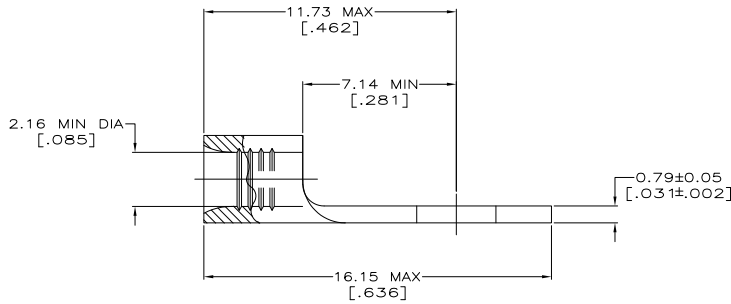

AMP INCORPORATED CUSTOMER SERVICE SYSTEMS		MAX RECOMMENDED OPERATING TEMPERATURE: 170° C MAX
FOR ADDITIONAL PRODUCT INFORMATION OR COPIES OF DRAWINGS AND TECHNICAL DOCUMENTS	PRODUCT INFORMATION CENTER 1-800-522-6752	VOLTAGE RATING: NOT APPLICABLE
FOR APPLICATION TOOLING INFORMATION	TOOLING ASSISTANCE CENTER 1-800-722-1111	WIRE CROSS SECTIONAL AREA RANGE: 1.04-2.62mm ² [2,050-5,180] CIR MILS SOLID OR STRANDED
FOR ORDER ENTRY	1-800-526-5142	THIS DRAWING IS A CONTROLLED DOCUMENT FOR AMP INCORPORATED. IT IS SUBJECT TO CHANGE AND THE CONTROLLING ENGINEERING ORGANIZATION SHOULD BE CONTACTED FOR THE LATEST REVISION.

△	-	LOOSE PIECE	34122-1
△	100	LOOSE PIECE, BOX	8-34122-1
	5000	ON TAPE	2-34122-1
	---	LOOSE PIECE	34122
FINISH	QUANTITY	PACKAGING TYPE	PART NO

THIS DRAWING IS A CONTROLLED DOCUMENT.		BY TA BRINKMAN 3-17-93	DATE 3-17-93	TE Connectivity
DIMENSIONS: mm[INCHES]		CHK DA PATTERSON 3-17-93	DATE 3-17-93	TE Connectivity
TOLERANCES UNLESS OTHERWISE SPECIFIED:		APP DE MILLER 3-17-93	DATE 3-17-93	TE Connectivity
0 P/C	±	PRODUCT SPEC		TERMINAL, RING TONGUE, SOLISTRAND
1 P/C	±	APPLICATION SPEC		
2 P/C	±			
3 P/C	±			
4 P/C	±			
ANGLES	±			
MATERIAL COPPER PER ASTM-B-152 ANNEALED	FINISH	WEIGHT	SIZE A2	CAGE CODE 00779
			DRAWING NO 34122	RESTRICTED TO
		CUSTOMER DRAWING	SCALE 8:1	SHEET 1 of 1

141-9 (5/11)

34122