

THIS DRAWING IS UNPUBLISHED. RELEASED FOR PUBLICATION
 © COPYRIGHT - By - ALL RIGHTS RESERVED.

| LOC | DIST | REVISIONS | | | | | |
|-----|------|-----------|-----|---------------------------|---------|-----|------|
| G | 14 | P | LTR | DESCRIPTION | DATE | DWN | APVD |
| | | A4 | | REVISED PER ECO-11-005027 | 12MAR11 | RK | HMR |

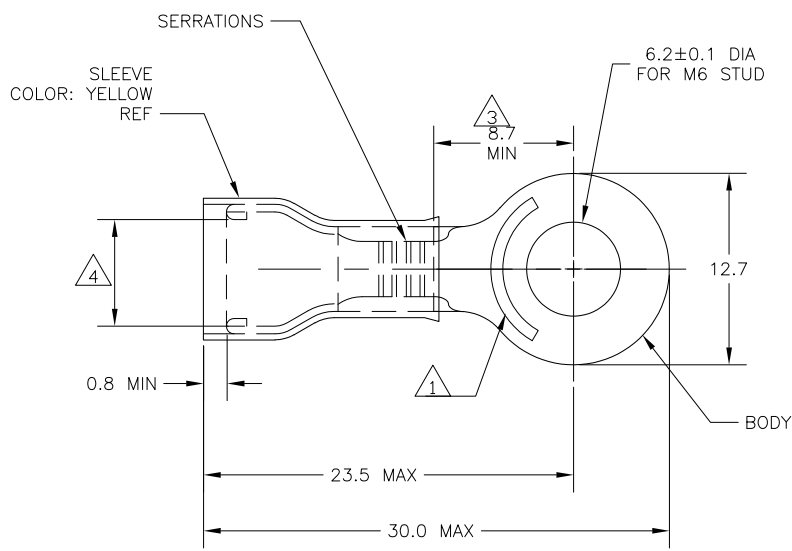

- 1 STAMP "AMP 12-10*", LOCATION APPROX AS SHOWN.
- 2 TONGUE THICKNESS IS 1.00±0.05
- 3 APPLIES TO EDGE OF METAL WIRE BARREL TO CENTER OF STUD HOLE.
- 4 WIRE INSULATION DIA RANGE 3.8-6.4
- 5 BODY - COPPER PER ASTM B152 SLEEVE - COPPER PER ASTM B152 INSULATION - NYLON
- 6 BODY - TIN PLATE PER ASTM B545 SLEEVE - TIN PLATE PER ASTM B545 INSULATION - COLOR-YELLOW
- 7 105°C MAX OPERATING TEMP.
- 8 300 VOLT MAX
- 9 2.62-6.64mm² [5,180-13,100 CMA] SOLID OR STRANDED

| | | |
|------|----------------|------------|
| 2500 | ON TAPE & REEL | 2-165028-1 |
| 500 | LOOSE PIECE | 165028 |
| QTY | PACKAGE TYPE | PART NO |

| | | | | |
|--|-------------|----------------------------------|---|--------------------|
| THIS DRAWING IS A CONTROLLED DOCUMENT. | | DWN jr_ruth 29MAR07 | TE Connectivity | |
| DIMENSIONS: MM | | CHK T MICHIELUTTI 29MAR07 | | |
| TOLERANCES UNLESS OTHERWISE SPECIFIED: | | APVD T MICHIELUTTI 29MAR07 | NAME TERMINAL RING TONGUE, PIDG, WIRE SIZE 12-10 | |
| 0 PLC ± - | 1 PLC ± 0.2 | PRODUCT SPEC | RESTRICTED TO | |
| 2 PLC ± - | 3 PLC ± - | APPLICATION SPEC | SIZE A3 | CAGE CODE 00779 |
| 4 PLC ± - | ANGLES ± 5° | WEIGHT | DRAWING NO C=165028 | SCALE 4:1 |
| MATERIAL | FINISH | CUSTOMER DRAWING | SHEET 1 of 1 | REV A4 |