

DRAWING MADE IN THIRD ANGLE PROJECTION
 THIS DRAWING IS UNPUBLISHED. RELEASED FOR PUBLICATION .19
 © COPYRIGHT 19 BY AMP INCORPORATED. ALL INTERNATIONAL RIGHTS RESERVED.

LOC		DIST		ZONE		LTR		REVISIONS		DATE	APPD
AF	50	P	F					C	REV PER 0710-0522-95	110ECS	RG/NN

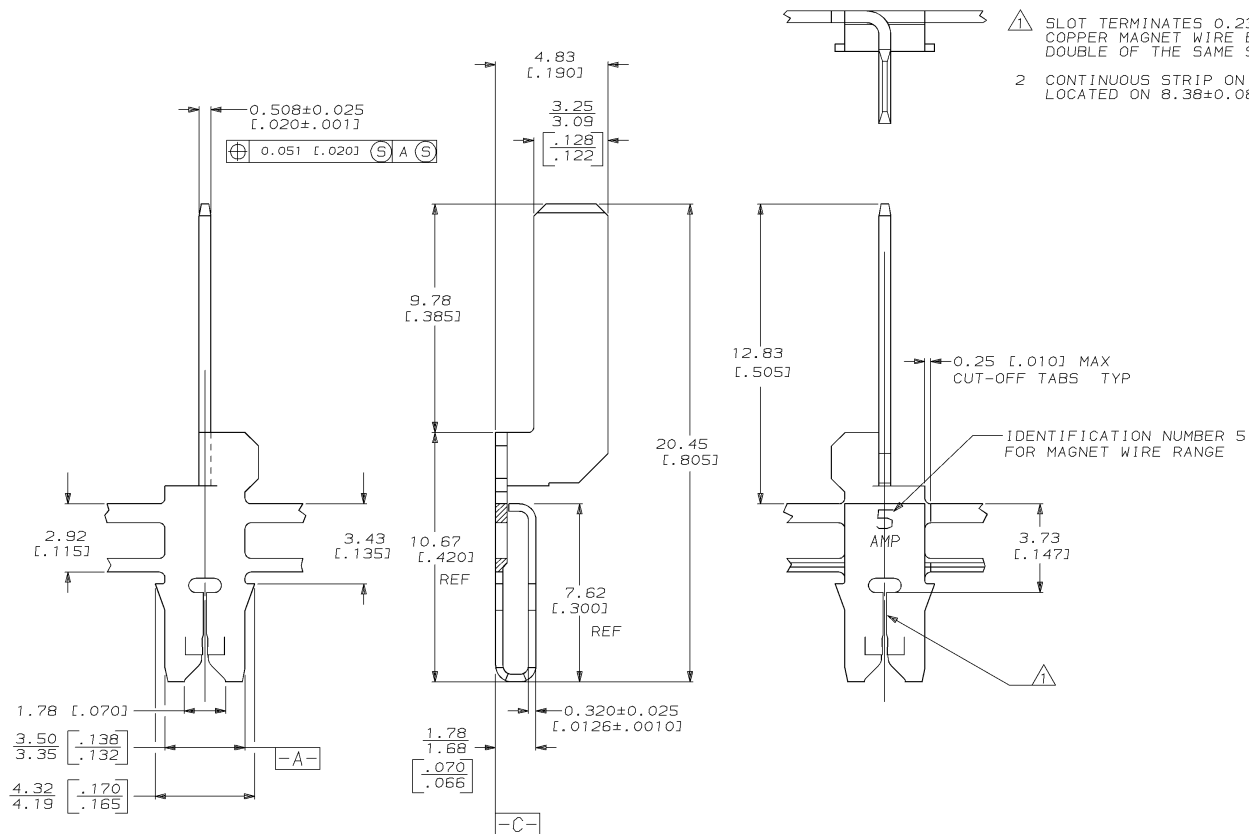

△ SLOT TERMINATES 0.23-0.32mm [#31-#28] AWG COPPER MAGNET WIRE EITHER SINGLE OR DOUBLE OF THE SAME SIZE.
 2 CONTINUOUS STRIP ON REELS WITH TERMINALS LOCATED ON 8.38±0.08 [.330±.003] CENTERS.

0.25 [.010] MAX CUT-OFF TABS TYP

IDENTIFICATION NUMBER 5 FOR MAGNET WIRE RANGE

AMP

63807-1
PART NO

DO NOT SCALE PRINT. UNLESS SPECIFIED DIMENSIONS IN mm [INCHES] TOLERANCES ON: 1 PLC DEC ± 0.25 [.010] 2 PLC DEC ± - 3 PLC DEC ± - ANGLES ± -		DR 19/SEP/94 MICHAEL S. FEHER	AMP Incorporated Harrisburg, PA 17105-3608	
MATERIAL #4M PRE-MILLED BRASS		CHK 21/SEP/94 JEFF R. RUTH		
FINISH 0.002032 [.000080] MIN TIN PER MIL-T-10727		APPD 21/SEP/94 NELSON E. NEFF	NAME TERMINAL, TAB, 3.18 [.125], MAG-MATE™	
APPLICATION SPEC 114-2046		APPD 21/SEP/94 TERRY L. SHUTTER	PRODUCT SPEC 108-2012	SIZE C 00779
WEIGHT -		DRAWING NO C-63807		CAGE CODE 00779
		SCALE 8:1		DRAWING NO C-63807
				SHEET 1 OF 1

THIS DRAWING IS A CONTROLLED DOCUMENT FOR AMP INCORPORATED. IT IS SUBJECT TO CHANGE AND THE CONTROLLING ENGINEERING ORGANIZATION SHOULD BE CONTACTED FOR THE LATEST REVISION.

AMP 1471-6 REV 3-92
 11-DEC-95 08:40:29 amq21428 /ws/dept2127/dwg2127/u_maa-mate/u_300

CUSTOMER DRAWING