

THIS DRAWING IS UNPUBLISHED. RELEASED FOR PUBLICATION .19  
 © COPYRIGHT 19 BY AMP INCORPORATED. ALL INTERNATIONAL RIGHTS RESERVED.

LOC	DIST	REV	DATE	BY	APPD	DESCRIPTION
AF	50					REL TO PRODUCTION 0710-0037-94

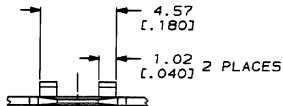

IDENTIFICATION NUMBER 5 FOR MAGNET WIRE RANGE

1 CONTINUOUS STRIP ON REELS WITH TERMINALS LOCATED ON  $8.38 \pm 0.08$  [0.330 ± 0.003] CENTERS. SLOT TERMINATES EITHER A SINGLE OR DOUBLE MAGNET WIRES OF THE SAME TYPE AND SIZE. COPPER RANGE: 0.23-0.32mm [#31-#28] AWG.

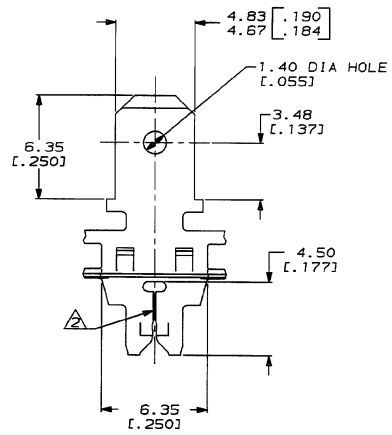
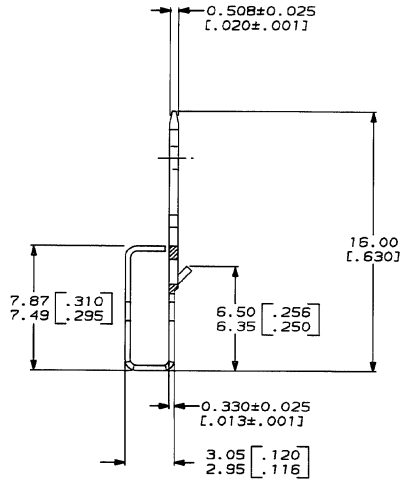
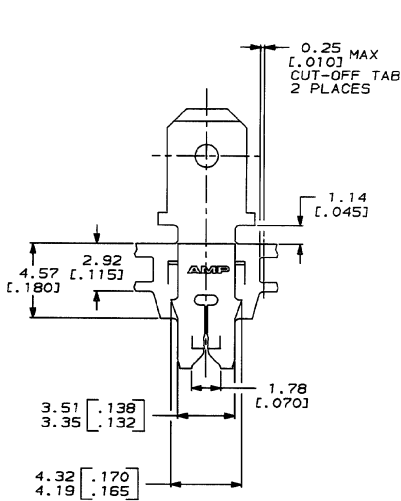

DO NOT SCALE PRINT. UNLESS SPECIFIED DIMENSIONS IN mm (INCHES) TOLERANCES ON: 2 PLG DEC ± 0.25 (0.010) 3 PLG DEC ± - ANGLES ± -		DR 04/DEC/93 MICHAEL S. FEMER	63760-1 PART NO	
MATERIAL 4M PRE-MILLED BRASS	CHK 06/DEC/93 PHILLIP M. FORTNEY	NAME TERRY L. SMUTER	AMP Incorporated Harrisburg, PA 17105-3608	
FINISH 0.002032 [0.000080] MIN TIN PER MIL-T-10727	APPD 07/DEC/93 TERRY L. SMUTER	PRODUCT SPEC 108-2012	TAB, 4.75 [0.187] FASTON™ MAG-MATE™	
	APPLICATION SPEC 114-2094	SIZE C	CAGE CODE 00779	DRAWING NO C-63760
	WEIGHT	SCALE 6:1	SHEET 1 OF 1	

THIS DRAWING IS A CONTROLLED DOCUMENT FOR AMP INCORPORATED. IT IS SUBJECT TO CHANGE AND THE CONTROLLING ENGINEERING ORGANIZATION SHOULD BE CONTACTED FOR THE LATEST REVISION.