

DRAWING MADE IN THIRD ANGLE PROJECTION

THIS DRAWING IS UNPUBLISHED. RELEASED FOR PUBLICATION, 19
 © COPYRIGHT 19 BY AMP INCORPORATED. ALL INTERNATIONAL RIGHTS RESERVED.

LOC	DIST	REVISIONS				
P	F	ZONE	LTR	DESCRIPTION	DATE	APPD
AF	50		C	REV PER AF-6942	8/23/90	

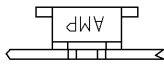

- 1 CONTINUOUS STRIP ON REELS WITH TERMINALS LOCATED ON 5.08 [.200] CENTERS
- 2 SLOT ACCEPTS 0.18-0.23mm DIA [#33-#31]AWG COPPER MAGNET WIRE
- 3 TIN LEAD 0.00380 [.000150] MIN PER MIL-T-10727 OVER NICKEL 0.00127 [.000050] MIN PER QQ-N-290.

IDENTIFICATION NUMBER FOR MAGNET WIRE RANGE

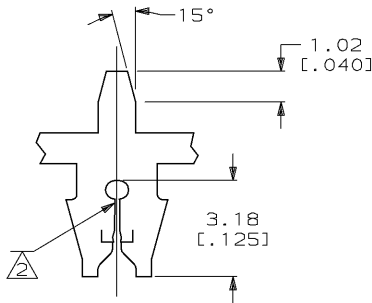
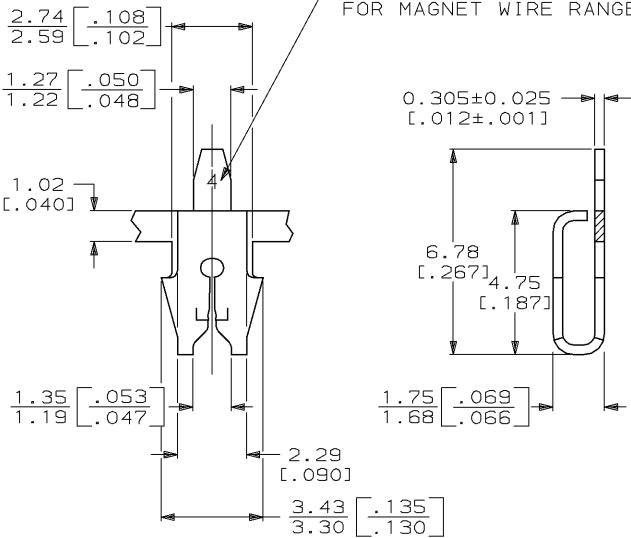

METRIC

63565-1

PART NO

DO NOT SCALE PRINT. UNLESS SPECIFIED DIMENSIONS IN mm [INCHES] TOLERANCES ON: 2 PLC DEC ± 0.25(.010) 3 PLC DEC ± - ANGLES ± -	DR 1/10/90 M.S. FEHR CHK 1/11/90 J.R. RUTH APPD 1/11/90 N.E. NEFF APPD 1/12/90 T.L. SHUTTER	AMP AMP INCORPORATED Harrisburg, Pa. 17105	
MATERIAL #4 HARD BRASS	PRODUCT SPEC -	NAME TERMINAL, POSTED, MAG-MATE™	
FINISH 3	APPLICATION SPEC 114-2069	SIZE B	CAGE CODE 00779
WEIGHT -		DRAWING NO 63565	SHEET 1 OF 1
		SCALE 8:1	

CUSTOMER DRAWING