

DRAWING MADE IN THIRD ANGLE PROJECTION
 THIS DRAWING IS UNPUBLISHED. RELEASED FOR PUBLICATION .19
 © COPYRIGHT 19 BY AMP INCORPORATED. ALL INTERNATIONAL RIGHTS RESERVED.

LOC		DIST		ZONE		LTR		REVISIONS		DATE	APPD
AF	50	P	F					C	REVISED & REDRAWN PER 0710-0455-94	14/JAN/95	MF/NN

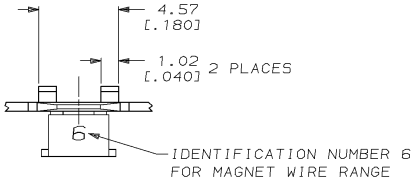

1 CONTINUOUS STRIP ON REELS WITH TERMINALS LOCATED ON 8.38±0.08 [0.330±.003] CENTERS. SLOTTED ACCEPTS 0.25-0.36mm [#30-#27] AWG COPPER MAGNET WIRE. 2 WIRES OF THE SAME SIZE MAX PER SLOT.

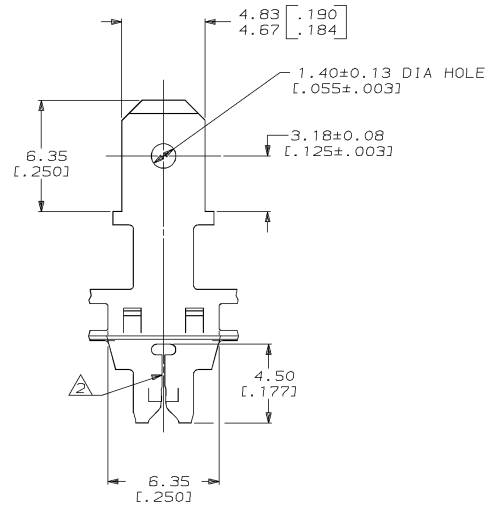
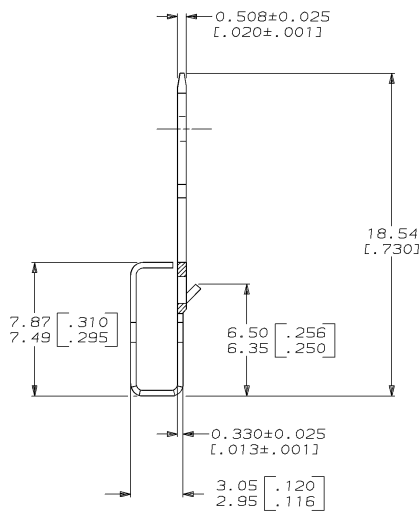
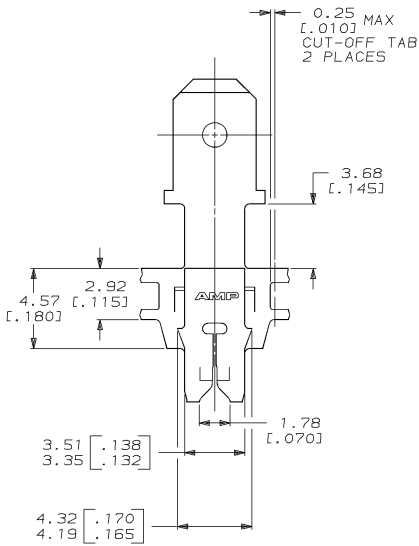

63447-1
PART NO

DO NOT SCALE PRINT. UNLESS SPECIFIED DIMENSIONS IN mm [INCHES] TOLERANCES ON: 2 PLC DEC ± 0.25 (.010) 3 PLC DEC ± - ANGLES ± -		DR 14/JAN/95 MICHAEL S. FEHER	AMP AMP Incorporated Harrisburg, PA 17105-3608	
MATERIAL 4M PRE-MILLED BRASS	APPD 16/JAN/95 NELSON E. NEFF	CHK 16/JAN/95 PHILLIP M. FORTNEY	NAME TAB, 4.75 [0.187] FASTON™, MAG-MATE™	
FINISH 0.002032 [0.00080] MIN TIN PER MIL-T-10727	APPD 16/JAN/95 TERRY L. SHUTTER	PRODUCT SPEC 108-2012	SIZE CAGE CODE 00779	DRAWING NO C=63447
	APPLICATION SPEC 114-2094	WEIGHT	SCALE 6:1	SHEET 1 OF 1

THIS DRAWING IS A CONTROLLED DOCUMENT FOR AMP INCORPORATED. IT IS SUBJECT TO CHANGE AND THE CONTROLLING ENGINEERING ORGANIZATION SHOULD BE CONTACTED FOR THE LATEST REVISION.

CUSTOMER DRAWING