

DRAWING MADE IN THIRD ANGLE PROJECTION

THIS DRAWING IS UNPUBLISHED. RELEASED FOR PUBLICATION, 19 .
 © COPYRIGHT 19 BY AMP INCORPORATED. ALL INTERNATIONAL RIGHTS RESERVED.

LOC	DIST	REVISIONS				
P	F	ZONE	LTR	DESCRIPTION	DATE	APPD
AF	50		E	REVISED PER 0232-93	8/4/93	PF/NN



- 1 CONTINUOUS STRIP ON REELS WITH TERMINALS LOCATED ON 5.08 [.200] CENTERS
- 2 SLOT ACCEPTS 0.25-0.32mm [#30-#28]AWG COPPER MAGNET WIRE
- 3 TIN LEAD 0.00380 [.000150] MIN PER MIL-T-10727 OVER NICKEL 0.00127 [.000050] MIN PER QQ-N-290.

IDENTIFICATION NUMBER FOR MAGNET WIRE RANGE

2.74 [.108]
2.59 [.102]

1.27 [.050]
1.22 [.048]

1.02 [.040]

1.35 [.053]
1.19 [.047]

2.29 [.090]

3.43 [.135]
3.30 [.130]

0.305±0.025
[.012±.001]

6.78 [.267]
4.75 [.187]

1.75 [.069]
1.68 [.066]

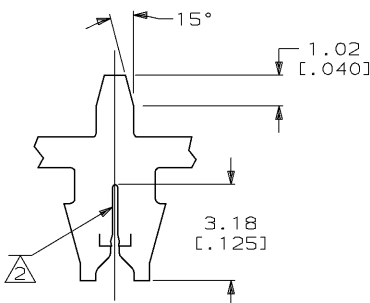

METRIC

63160-1

PART NO

DO NOT SCALE PRINT. UNLESS SPECIFIED DIMENSIONS IN mm [INCHES] TOLERANCES ON: 2 PLC DEC ± 0.25 [.010] 3 PLC DEC ± - ANGLES ± -	DR 7/16/90 M.S. FEHR	AMP INCORPORATED Harrisburg, Pa. 17105 TERMINAL, TAB, MAG-MATE™
MATERIAL #4 HARD BRASS	CHK 7/20/90 J.R. RUTH	
FINISH 3	APPD 7/20/90 N.E. NEFF	
	APPD 7/20/90 T.L. SHUTTER	
	PRODUCT SPEC 108-2012	NAME
	APPLICATION SPEC 114-2069	SIZE B CAGE CODE 00779 DRAWING NO 63160
	WEIGHT -	SCALE 8:1 SHEET 1 OF 1