

DRAWING MADE IN THIRD ANGLE PROJECTION
 THIS DRAWING IS UNPUBLISHED. RELEASED FOR PUBLICATION
 © COPYRIGHT 19 BY AMP INCORPORATED. ALL INTERNATIONAL RIGHTS RESERVED.

LOC	DIST	P	F	ZONE	LTR	REVISIONS	DATE	APPD
AF	50				F	REVISED PER 0710-0453-95	20/OCT/95	MF/NN

- CONTINUOUS STRIP ON REELS WITH TERMINALS LOCATED ON 5.59±0.08 [.220±.003] CENTERS.
- SLOT ACCEPTS A SINGLE WIRE MAX OF 0.18-0.23mm [#33-#31] AWG COPPER MAGNET WIRE.
- POKE-IN ACCEPTS A 0.5-0.8mm² [#20-#18] AWG SOLID OR FUSED STRANDED LEAD WIRE.
- AFTER INSERTION INTO PLASTIC HOLDER TAB PORTION MUST BE BENT OVER 45° TO 90° OR POTTED-IN TO PREVENT PULL-OUT WHEN MATING RECEPTACLE IS DISCONNECTED.

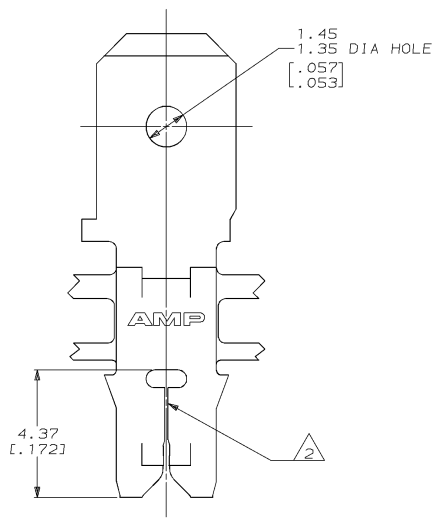
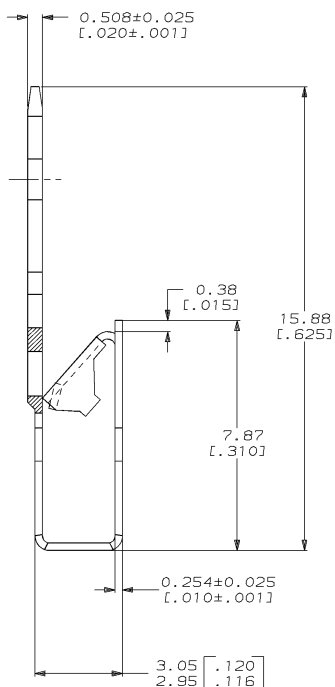
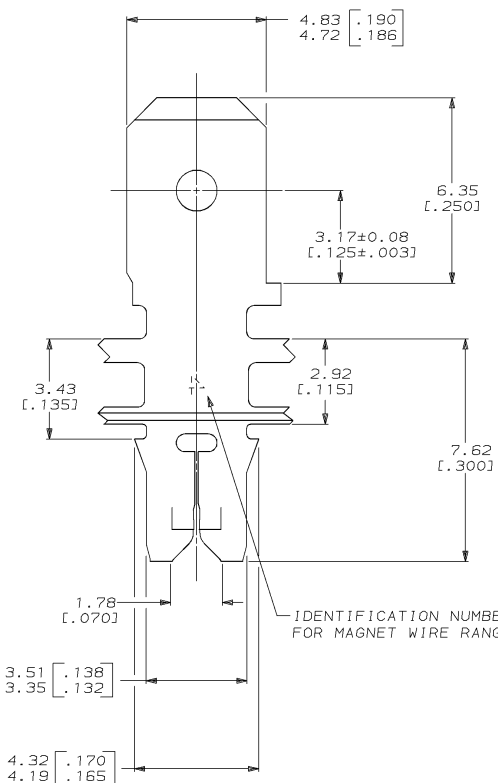
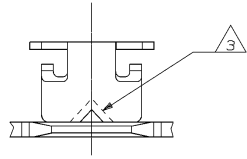

		63018-1	
		PART NO	
DO NOT SCALE PRINT. UNLESS SPECIFIED DIMENSIONS IN mm [INCHES] TOLERANCES ON 2 PLC DEC ± 0.25 (.010) 3 PLC DEC ± ANGLES ± -		DR 4-12-94 RAYMOND R. BUCHHEISTER JR.	AMP Incorporated Harrisburg, PA 17105-3608
MATERIAL 4M PRE-MILLED BRASS		CHK 4-22-94 MICHAEL S. FEHER	
FINISH 0.002032 (.000080) MIN TIN PER MIL-T-10727		APPD 4-27-94 NELSON E. NEFF	NAME TERMINAL, TAB, POKE-IN/4.75 [.187] FASTON™ COMBINATION, MAG-MATE™
		APPD 4-27-94 TERRY L. SHUTTER	PRODUCT SPEC 108-2012
		APPLICATION SPEC 114-2046	SIZE CAGE CODE DRAWING NO 00779 C-63018
		WEIGHT	SCALE 10:1 SHEET 1 OF 1

THIS DRAWING IS A CONTROLLED DOCUMENT FOR AMP INCORPORATED. IT IS SUBJECT TO CHANGE AND THE CONTROLLING ENGINEERING ORGANIZATION SHOULD BE CONTACTED FOR THE LATEST REVISION.

CUSTOMER DRAWING