

DRAWING MADE IN THIRD ANGLE PROJECTION

THIS DRAWING IS UNPUBLISHED. RELEASED FOR PUBLICATION, 19 .  
 © COPYRIGHT 19 BY AMP INCORPORATED. ALL INTERNATIONAL RIGHTS RESERVED.

LOC	DIST	REVISIONS				
P	F	ZONE	LTR	DESCRIPTION	DATE	APPD
AF	50		C	REV PER 0710-0165-95	5/12/95	JR/NN

IDENTIFICATION NUMBER 4 FOR MAGNET WIRE RANGE

- ① SLOT ACCEPTS 0.18-0.23mm DIA [#33-#31]AWG COPPER MAGNET WIRE
- ② 0.00203-0.00635 [.000080-.000250] TIN PLATE PER MIL-T-10727 OVER 0.00254 [.000100] MIN COPPER UNDERPLATE PER MIL-C-14550.

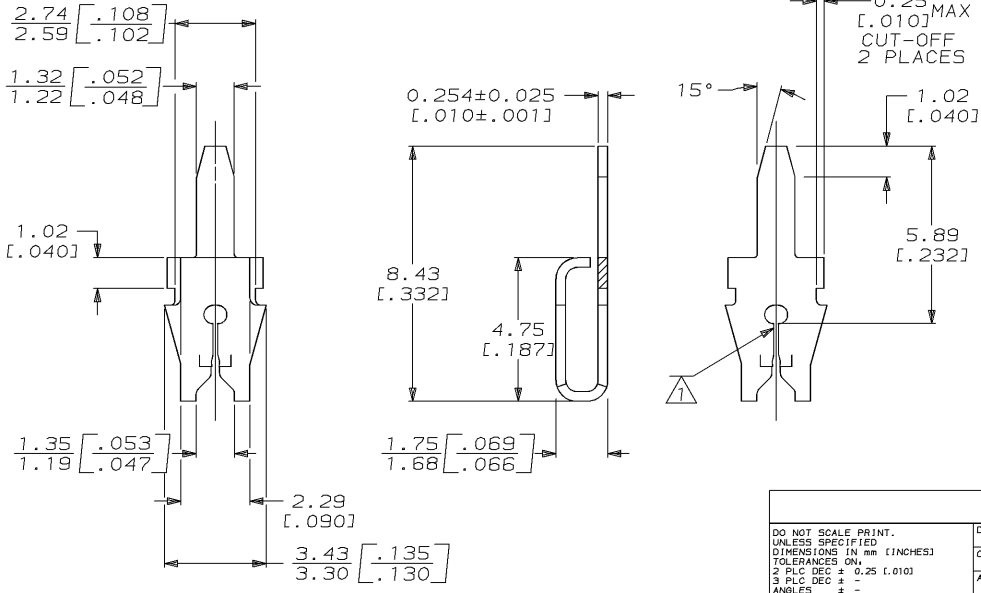

THIS DRAWING IS A CONTROLLED DOCUMENT FOR AMP INCORPORATED. IT IS SUBJECT TO CHANGE AND THE CONTROLLING ENGINEERING ORGANIZATION SHOULD BE CONTACTED FOR THE LATEST REVISION.

DO NOT SCALE PRINT. UNLESS SPECIFIED DIMENSIONS IN mm (INCHES) TOLERANCES ON: 2 PLC DEC ± 0.25 (.010) 3 PLC DEC ± - ANGLES ± -		DR 12/17/93 PHILLIP H FORTNEY	<b>AMP</b> AMP Incorporated Harrisburg, PA 17105-3608
MATERIAL H04 BRASS		CHK 12/17/93 MICHAEL S FEHER	
FINISH ②		APPD 12/17/93 NELSON E NEFF	NAME TERMINAL, POSTED, LOOSE PIECE, MAG-MATE™
		PRODUCT SPEC 108-2012	SIZE B
		APPLICATION SPEC 114-2069	CAGE CODE 00779
		WEIGHT -	DRAWING NO C=62934
			SCALE 8:1
			SHEET 1 OF 1

62934-1  
PART NO

AMP 1470-15 REV 3-92  
12-MAY-95 14:57:56 amp13469 /ws/dept2127/dwg2127/u.maq-mate/u.187

CUSTOMER DRAWING