

DRAWING MADE IN THIRD ANGLE PROJECTION

THIS DRAWING IS UNPUBLISHED. RELEASED FOR PUBLICATION, 19 .  
 © COPYRIGHT 19 BY AMP INCORPORATED. ALL INTERNATIONAL RIGHTS RESERVED.

LOC	DIST	REVISIONS				
P	F	ZONE	LTR	DESCRIPTION	DATE	APPD
AF	50		H	REV PER 0710-0196-96	18JUN96	RG/NN

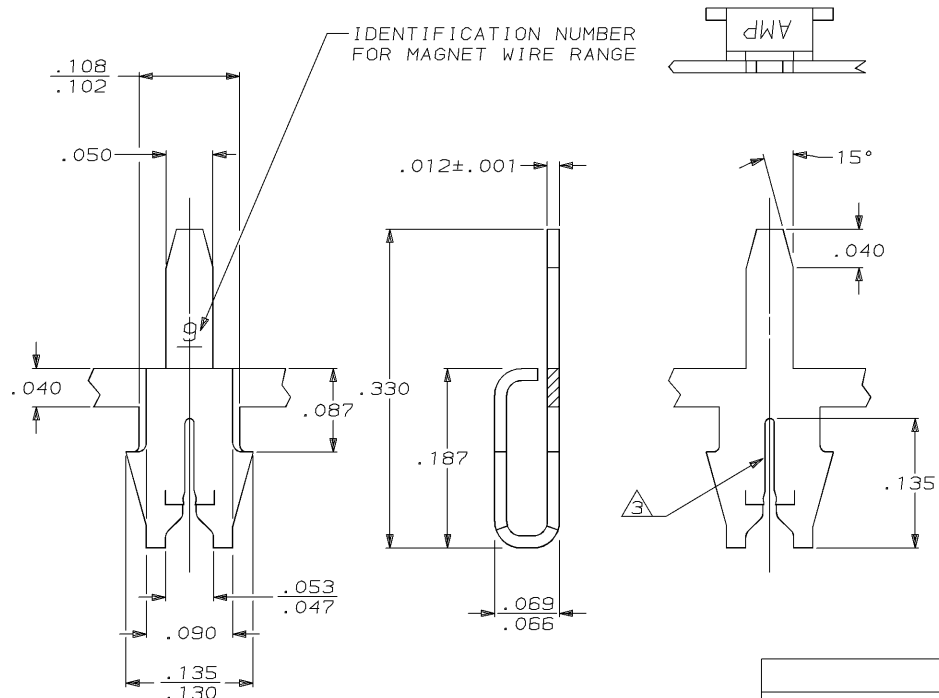

- ① MAG-MATE CAVITY SPECIFICATION.
- ② CONTINUOUS STRIP ON REELS WITH TERMINALS LOCATED ON .200 CENTERS.
- ③ SLOT ACCEPTS #27-#25 AWG COPPER MAGNET WIRE.
- ④ REELED FOR APPLICATION THROUGH MAG-MATE INSERTION MACHINE.
- ⑤ REELED FOR INSERTION INTO PRINTED CIRCUIT BOARD.
- ⑥ 0.002032[.000080] MIN TIN PER MIL-T-10727 OVER 0.00127[.000050] MIN NICKEL PER QQ-N-290

⑤	62438-2
④	62438-1
PART NO	
<b>AMP</b> AMP INCORPORATED Harrisburg, Pa. 17105	
NAME TERMINAL, POSTED, MAG-MATE™	
SIZE <b>B</b>	FSCM NO 00779
SCALE 10:1	DRAWING NO 62438
SHEET 1 OF 1	

DO NOT SCALE PRINT. UNLESS SPECIFIED DIMENSIONS IN INCHES TOLERANCES ON: 2 PLC DEC ± .010 3 PLC DEC ± .010 ANGLES ± -	DR 11/21/88 M.S. FEHER CHK 11/27/88 JR RUTH APPD 11/28/88 NELSON E. NEFF APPD 11/28/88 C.G. ATHERTON PRODUCT SPEC -
MATERIAL #4 HARD BRASS	FINISH ⑥

AMP 1470-15 REV 3-87  
 18-JUN-96 08:08:25 amp21428 /ws/dept2127/dwg2127/u.mag-mate/u.187

CUSTOMER DRAWING