

DRAWING MADE IN AMERICAN PROJECTION

© 1970 BY AMP INCORPORATED. ALL RIGHTS RESERVED. AMP PRODUCTS COVERED BY PATENTS AND/OR PATENTS PENDING.

REVISIONS				
ZONE	LTR	DESCRIPTION	DATE	APPROVED
	0	NPS 70-0606 (REV 2)	12-30-70	FCJ
	A	REVISED TO AGREE WITH PROD. DWG	1-21-71	FCJ
	B	REV PER ECN P-6553	3-23-71	FCJ
	C	REVISED F-55A	5-12-71	FCJ
	D	REVISED P-6602	6-23-71	FCJ
	E	REV U-1790	5-28-72	JW

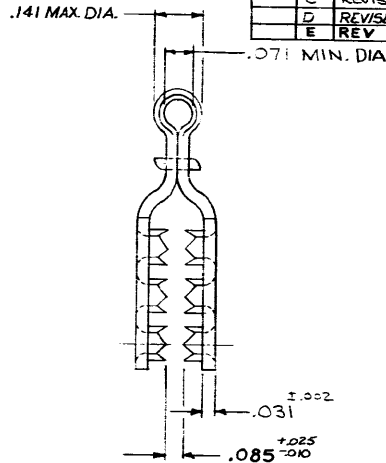
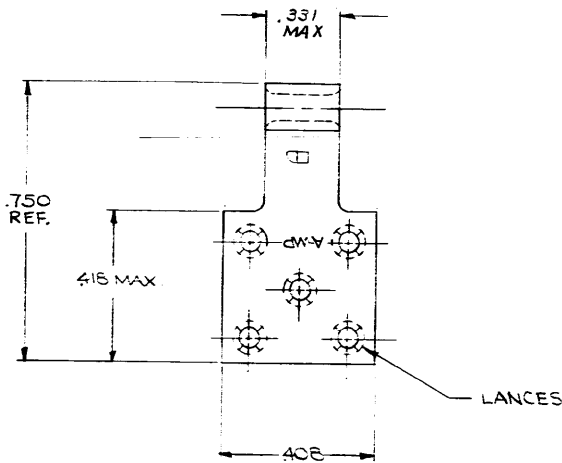

UNLESS OTHERWISE SPECIFIED DIMENSIONS ARE IN INCHES TOLERANCES ON: DECIMALS ± .008 ANGLES ± 5°	CONTRACT NO. <u>4</u>	<b>AMP</b> AMP INCORPORATED HARRISBURG, PENNSYLVANIA
	DR. <u>12-24-70</u> CHK. <u>12-31-70</u> APPD. <u>12-31-70</u> DGMN APPD. <u>12-31-70</u> OTHER APPD.	
MATERIAL COPPER (QQ-C-576) TIN PLATE (MIL-T-10727)	SIZE <b>B</b>	CODE IDENT NO. <b>00779</b>
	SCALE <b>4-1</b>	NUMBER <b>52584</b> SHEET <b>1 OF 1</b>