

DRAWING MADE IN THIRD ANGLE PROJECTION

THIS DRAWING IS UNPUBLISHED. RELEASED FOR PUBLICATION  
 © COPYRIGHT 19 BY AMP INCORPORATED. ALL INTERNATIONAL RIGHTS RESERVED.

LOC	DIST	REV	ZONE	LTR	DESCRIPTION	DATE	APPD
AF	50			G	REVISED PER 063A-0315-01	MF-DD	08MAY01

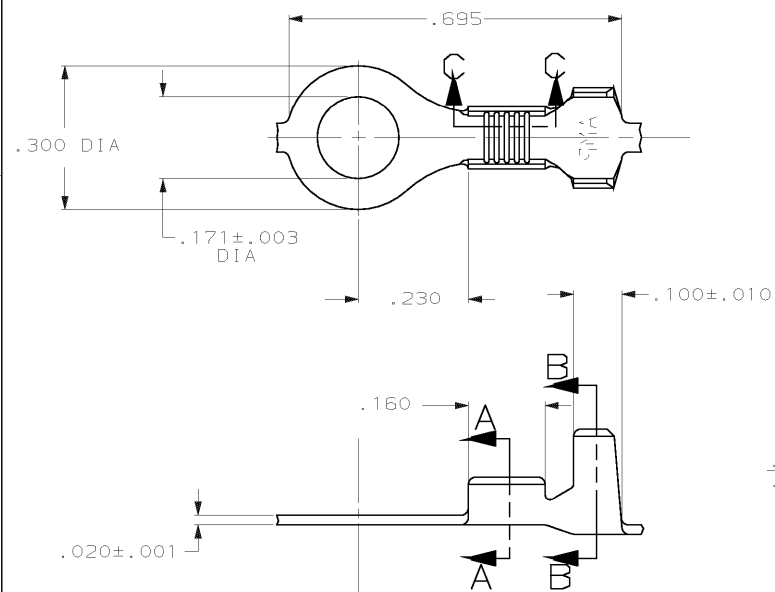

1 CONTINUOUS STRIP ON REELS

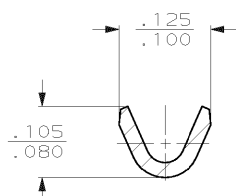

SECTION A-A  
SCALE 8:1

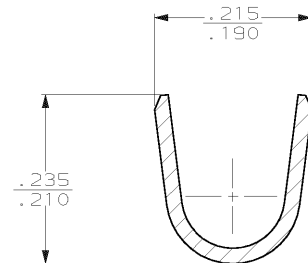

SECTION B-B  
SCALE 8:1

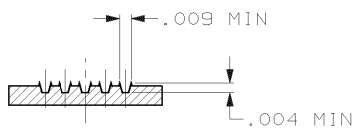

SECTION C-C  
SCALE 10:1

.125-.165 DIA	23-19 AWG	60323-2
---------------	-----------	---------

INSULATION RANGE      MAGNET WIRE RANGE      PART NO

DO NOT SCALE PRINT. UNLESS SPECIFIED DIMENSIONS IN INCHES TOLERANCES ON: 2 PLC DEC ± 3 PLC DEC ± .015 ANGLES ± -	DR 3/1/90 P FORNEY	<b>AMP</b> AMP INCORPORATED Harrisburg, Pa. 17105  NAME #8 STUD RING, AMPLIVAR
	CHK 3/1/90 MS FEHER	
	APPD 3/1/90 G YETTER	
	APPD 3/10/90 R KUZO	
MATERIAL #2 HARD BRASS	PRODUCT SPEC -	SIZE <b>B</b>
FINISH .000080 MIN TIN PLATE	APPLICATION SPEC -	CAGE CODE 00779
	WEIGHT -	DRAWING NO 60323
		SCALE 5:1
		SHEET 1 OF 1

CUSTOMER DRAWING