

4

3

2

1

THIS DRAWING IS UNPUBLISHED. RELEASED FOR PUBLICATION
 © COPYRIGHT - By - ALL RIGHTS RESERVED.

LOC	DIST	REVISIONS			
P	LTR	DESCRIPTION	DATE	DWN	APVD
AF	50	L2	REVISED PER ECO-11-005027	12MAR11	RK HMR

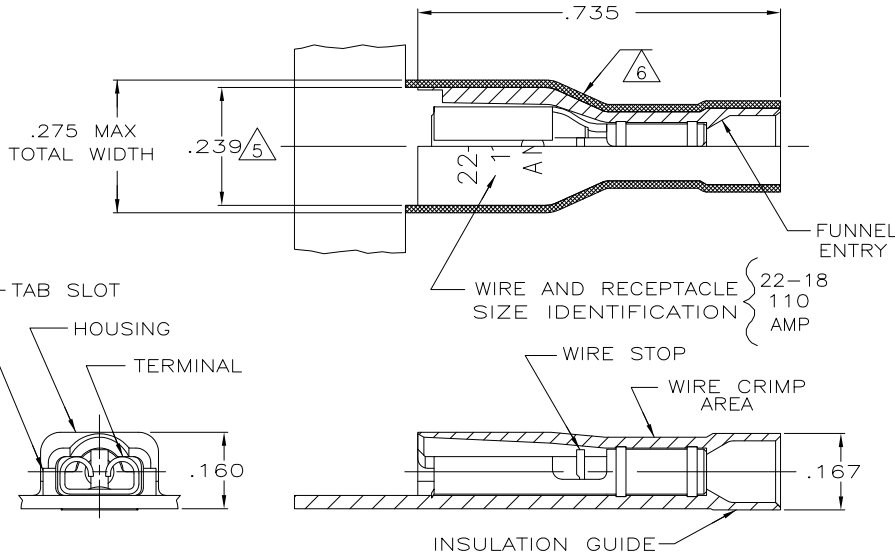

- 1 MATES WITH .032±.001x.110 OR .125 TAB
- 2 WIRE STRIP LENGTH .281
- 3 INSULATION SIZE .120 MAX DIA
- 4 CONTINUOUS STRIP ON REELS
- △5 DIMENSION DOES NOT INCLUDE TRIM BURR
- △6 .015 MAX CARRIER TRIM BURR PER SIDE IS ALLOWABLE IN THE SHADED AREA

HOUSING: NYLON, COLOR-BLACK TRANSLUCENT RECEPTACLE: #3 HARD BRASS TIN PL .000080 MIN THK	9-520272-2
HOUSING: NYLON, COLOR-RED TRANSLUCENT RECEPTACLE: #3 HARD BRASS TIN PL .000080 MIN THK	2-520272-2
MATERIAL & FINISH	PART NO

THIS DRAWING IS A CONTROLLED DOCUMENT.		DWN P FORTNEY 11/9/88	TE Connectivity	
DIMENSIONS: INCHES		CHK MS FEHER 11/9/88		
TOLERANCES UNLESS OTHERWISE SPECIFIED:		APVD K RANDOLPH 11/11/88	NAME RECEPTACLE ASSY, ULTRA-FAST, .110/.125 SERIES, 22-18AWG	
0 PLC ± -		PRODUCT SPEC 108-2043	APPLICATION SPEC	
1 PLC ± -		114-2123	RESTRICTED TO	
2 PLC ± -		WEIGHT	SIZE A3	CAGE CODE 00779
3 PLC ± .015		FINISH	DRAWING NO C-520272	SCALE 5:1
4 PLC ± -		MATERIAL SEE TABLE	SHEET 1 OF 1	
ANGLES ± -		FINISH SEE TABLE	REV L2	
MATERIAL SEE TABLE		CUSTOMER DRAWING		