

THIS DRAWING IS UNPUBLISHED. RELEASED FOR PUBLICATION 1999  
 © COPYRIGHT 1999 BY AMP INCORPORATED. ALL INTERNATIONAL RIGHTS RESERVED.

LOC	DIST	P	F	ZONE	LTR	REVISIONS	DATE	APPD
AF	50					REV PER 061A-0048-99	04/09/99	JR/DD

1 CONTINUOUS STRIP ON REEL.

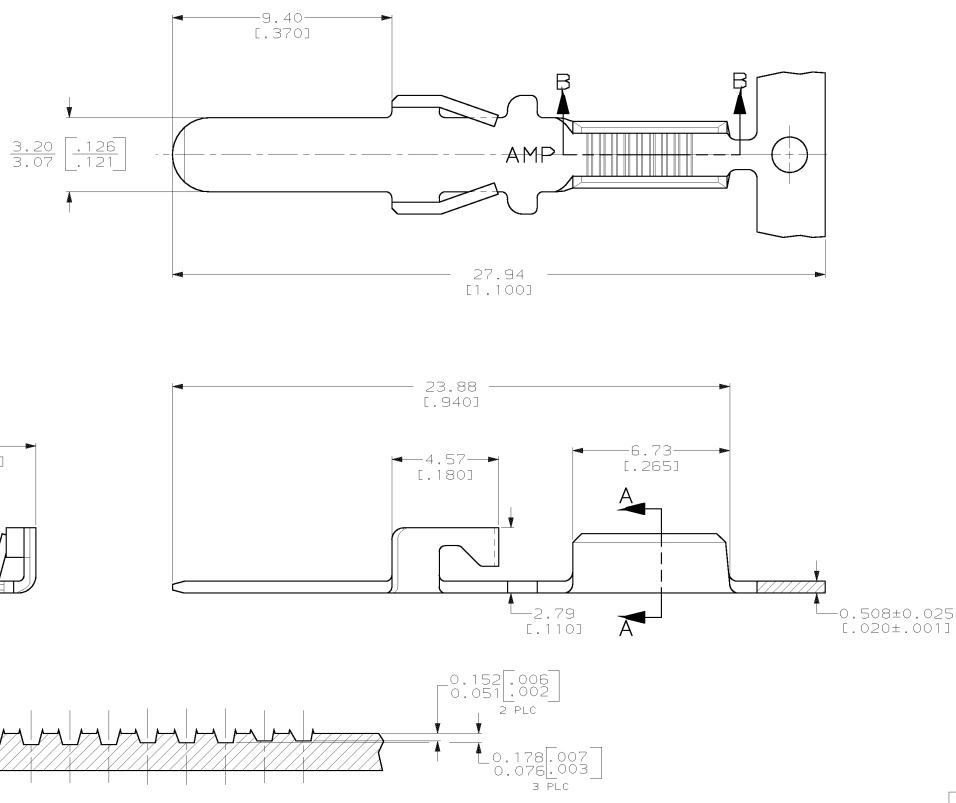

SECTION A-A  
SCALE 10:1

SECTION B-B  
SCALE 25:1

400-1600 CMA RANGE	1217029-1
WIRE RANGE	PART NO
<b>AMP</b> AMP Incorporated Harrisburg, PA 17105-3608	
NAME <b>CONTACT, 3.18 [0.125] BLADE, AMPLIVAR</b>	
MATERIAL 082 BRASS	FINISH 0.002032 [0.00080] MIN TIN PL PER MIL-T-10727
DR D4/NOV/97 PHILLIP M FORTNEY	CHK 04/NOV/97 JEFF R RUTH
APPD 04/NOV/97 SUE WRIGHT	APPD 04/NOV/97 DON DECKER
PRODUCT SPEC -	APPLICATION SPEC -
SIZE C	CAGE CODE 00779
SCALE 8:1	DRAWING NO C-1217029
WEIGHT -	SHEET 1 OF 1

THIS DRAWING IS A CONTROLLED DOCUMENT FOR AMP INCORPORATED. IT IS SUBJECT TO CHANGE AND THE CONTROLLING ENGINEERING ORGANIZATION SHOULD BE CONTACTED FOR THE LATEST REVISION.

CUSTOMER DRAWING