

4

3

2

1

THIS DRAWING IS UNPUBLISHED. RELEASED FOR PUBLICATION
 © COPYRIGHT - By - ALL RIGHTS RESERVED.

LOC	DIST	REVISIONS			
P	LTR	DESCRIPTION	DATE	DWN	APVD
AF	50	M	REVISED PER ECR-11-018063	26DEC11	KH PD

- CONTINUOUS STRIP ON REELS.
- WIRE SIZE [#22-#18] AWG.
- INSULATION RANGE IS 2.16-3.18 [.085-.125] DIA.

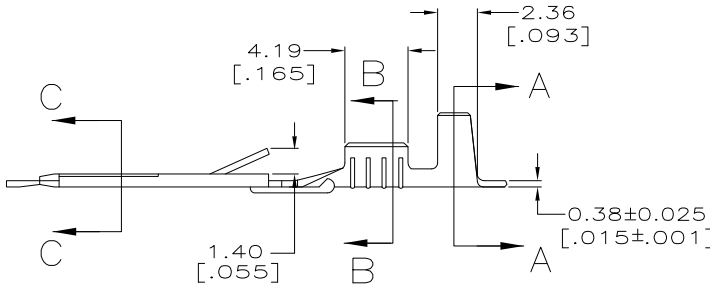
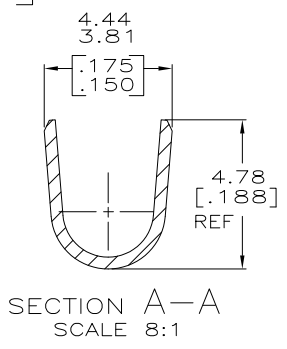
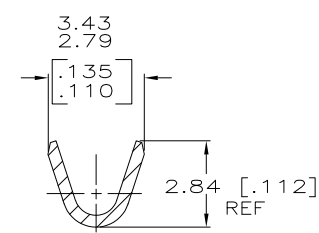
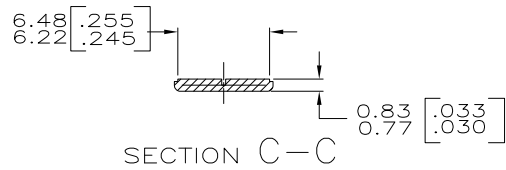
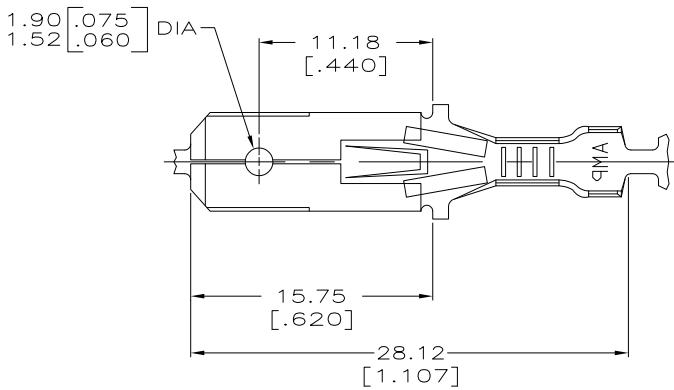

PRE-TIN	62553-4
TIN	62553-3
-	62553-1
FINISH	PART NO.

THIS DRAWING IS A CONTROLLED DOCUMENT.		DWN	JR RUTH	3/27/97
DIMENSIONS: mm [INCHES]		CHK	MS FEHER	3/27/97
TOLERANCES UNLESS OTHERWISE SPECIFIED:		APVD	J GILLESPIE	3/27/97
0 PLC	± -	NAME		
1 PLC	± -	TE Connectivity		
2 PLC	± 0.38 [.015]	TAB, FASTIN-FASTON, 6.35 [.250] SERIES		
3 PLC	± -	PRODUCT SPEC		
4 PLC	± -	APPLICATION SPEC		
ANGLES	± -	SIZE	114-2025	RESTRICTED TO
MATERIAL	082 BRASS	CAGE CODE	00779	DRAWING NO
FINISH	SEE TABLE	©	62553	—
		WEIGHT	-	—
		CUSTOMER DRAWING	SCALE	4:1
		SHEET	1 OF 1	REV
				M