



STAP85025

RF power transistor, LdmoST plastic family N-channel enhancement-mode lateral MOSFETs

Target specification

Features

- Excellent thermal stability
- Common source configuration
- $P_{OUT} = 25\text{ W}$ with 15.7 dB gain @ 870 MHz / 13.6 V
- Plastic package
- ESD protection
- In compliance with the 2002/95/EC European directive

Description

The STAP85025 is a common source N-channel, enhancement-mode lateral field-effect RF power transistor. It is designed for high gain, broadband commercial and industrial applications. It operates at 13.6 V in common source mode at frequencies of up to 1 GHz. STAP85025 boasts the excellent gain, linearity and reliability of ST's latest LDMOS technology mounted in STAP ST advanced PowerSO-10RF package. STAP85025's superior linearity performance makes it an ideal solution for car mobile radio.

The STAP ST plastic package was designed to offer high reliability and high power capability. It has been specially optimized for RF needs and offers excellent RF performances and ease of assembly.

Mounting recommendations are available in www.st.com/rf/ (look for application note AN1294)

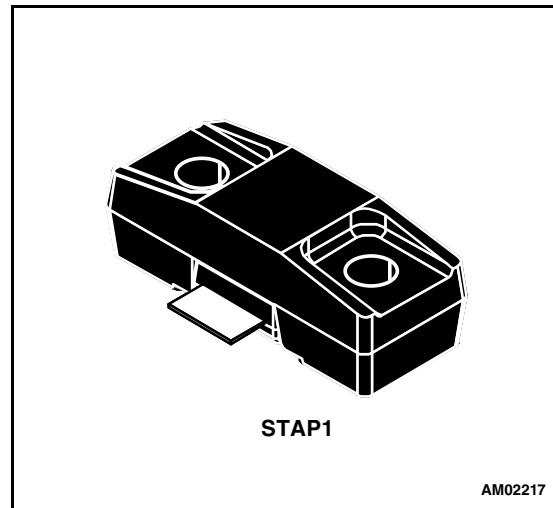

Figure 1. Pin connection

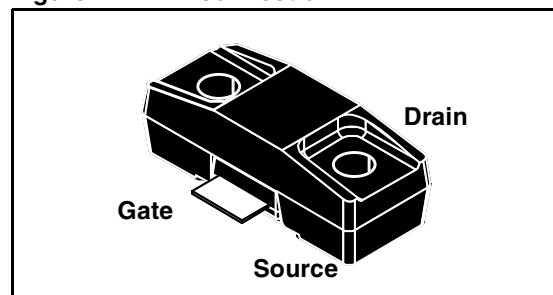

Table 1. Device summary

Order code	Package	Packaging
STAP85025	STAP1	Tube

Contents

1	Electrical data	3
	1.1 Maximum ratings	3
	1.2 Thermal data	3
2	Electrical characteristics	4
	2.1 Static	4
	2.2 Dynamic	4
3	Impedance	5
4	Typical performance	6
5	ECOPACK®	9
6	Revision history	11

1 Electrical data

1.1 Maximum ratings

Table 2. Absolute maximum ratings ($T_{CASE} = 25\text{ °C}$)

Symbol	Parameter	Value	Unit
$V_{(BR)DSS}$	Drain-source voltage	40	V
V_{GS}	Gate-source voltage	-0.5 to +15	V
I_D	Drain current	7	A
P_{DISS}	Power dissipation (@ $T_C = 70\text{ °C}$)	79	W
T_J	Max. operating junction temperature	165	°C
T_{STG}	Storage temperature	-65 to +150	°C

1.2 Thermal data

Table 3. Thermal data

Symbol	Parameter	Value	Unit
R_{thJC}	Junction - case thermal resistance	1.2	°C/W

2 Electrical characteristics

$$T_{\text{CASE}} = +25 \text{ }^{\circ}\text{C}$$

2.1 Static

Table 4. Static

Symbol	Test conditions		Min	Typ	Max	Unit	
I_{DSS}	$V_{\text{GS}} = 0 \text{ V}$	$V_{\text{DS}} = 25 \text{ V}$	-		1	μA	
I_{GSS}	$V_{\text{GS}} = 5 \text{ V}$	$V_{\text{DS}} = 0 \text{ V}$			1	μA	
$V_{\text{GS(Q)}}$	$V_{\text{DS}} = 10 \text{ V}$	$I_{\text{D}} = 300 \text{ mA}$			4.1	V	
$V_{\text{DS(ON)}}$	$V_{\text{GS}} = 10 \text{ V}$	$I_{\text{D}} = 1 \text{ A}$			0.27	0.31	V
C_{ISS}	$V_{\text{GS}} = 0 \text{ V}$	$V_{\text{DS}} = 12.5 \text{ V}$		$f = 1 \text{ MHz}$	55		pF
C_{OSS}	$V_{\text{GS}} = 0 \text{ V}$	$V_{\text{DS}} = 12.5 \text{ V}$		$f = 1 \text{ MHz}$	40		pF
C_{RSS}	$V_{\text{GS}} = 0 \text{ V}$	$V_{\text{DS}} = 12.5 \text{ V}$		$f = 1 \text{ MHz}$	1.5		pF

2.2 Dynamic

Table 5. Dynamic

Symbol	Test conditions		Min	Typ	Max	Unit
P3dB	$V_{\text{DD}} = 13.6 \text{ V}$, $I_{\text{DQ}} = 300 \text{ mA}$	$f = 870 \text{ MHz}$	25	30	-	W
G_{P}	$V_{\text{DD}} = 13.6 \text{ V}$, $I_{\text{DQ}} = 300 \text{ mA}$, $P_{\text{OUT}} = 10 \text{ W}$, $f = 870 \text{ MHz}$		15	17.3		dB
h_{D}	$V_{\text{DD}} = 13.6 \text{ V}$, $I_{\text{DQ}} = 300 \text{ mA}$, $P_{\text{OUT}} = \text{P3dB}$, $f = 870 \text{ MHz}$		60	66		%
Load mismatch	$V_{\text{DD}} = 17 \text{ V}$, $I_{\text{DQ}} = 300 \text{ mA}$, $P_{\text{OUT}} = 45 \text{ W}$, $f = 870 \text{ MHz}$ All phase angles		20:1			VSWR

2.3 ESD protection characteristics

Table 6. ESD protection characteristics

Test conditions	Class
Human body model	2
Machine model	M3

3 Impedance

Figure 2. Current conventions

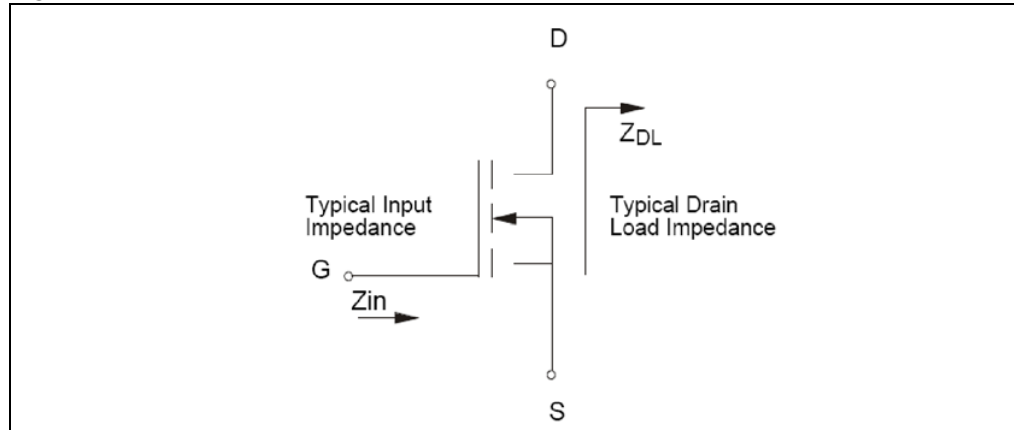

Table 7. Impedance data

Frequency (MHz)	Z_{IN} (Ω)	Z_{DL} (Ω)
870 MHz	$0.21 + j 1.82$	$1.23 - j 0.98$

4 Typical performances

Figure 3. Capacitances vs drain voltage

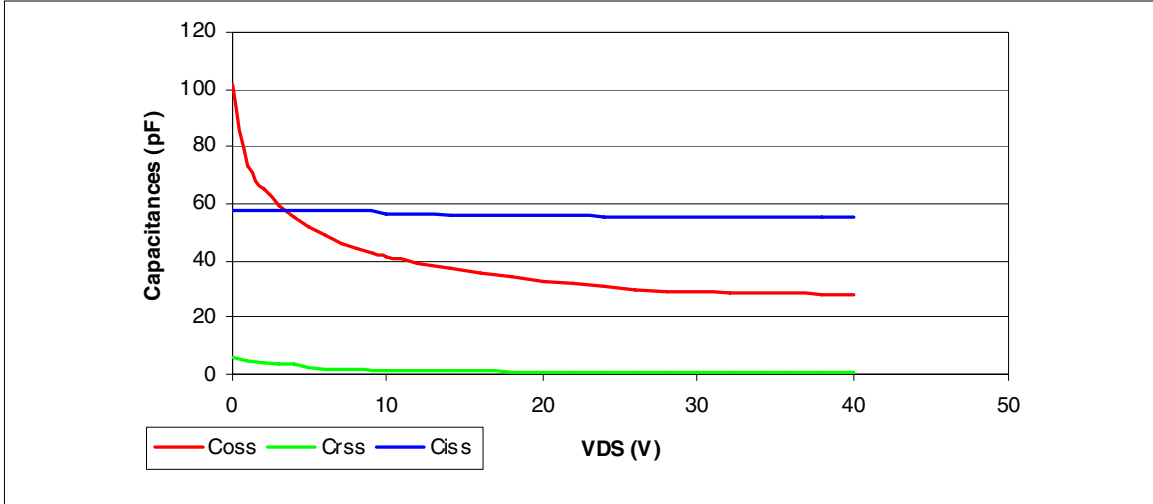

Figure 4. DC output characteristics (T_{amb} = -40 °C)

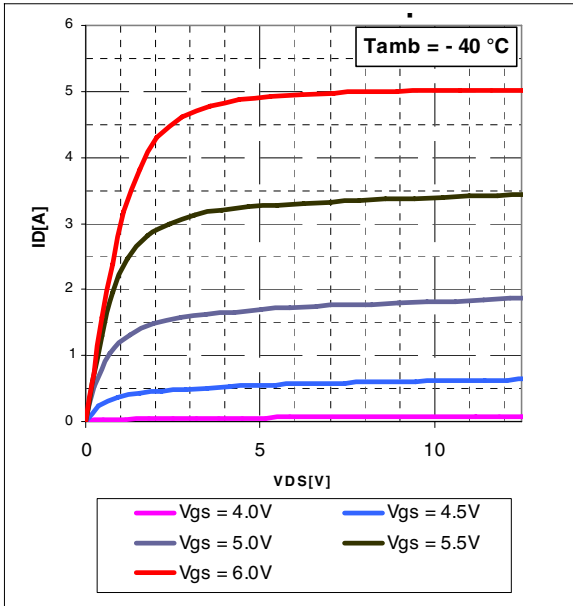

Figure 5. DC output characteristics (T_{amb} = 20 °C)

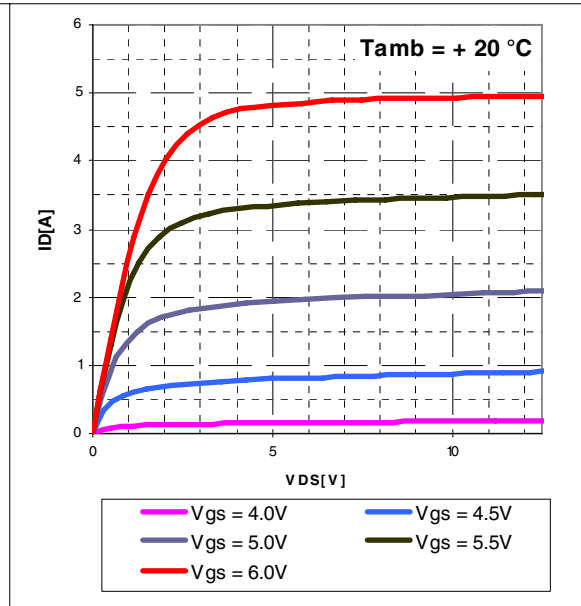

Figure 6. DC output characteristics
($T_{amb} = 60\text{ }^{\circ}\text{C}$)

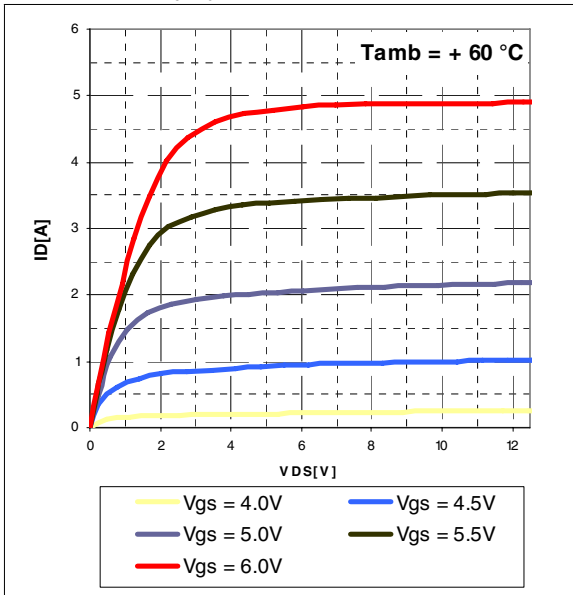

Figure 7. Gain vs output power and bias current

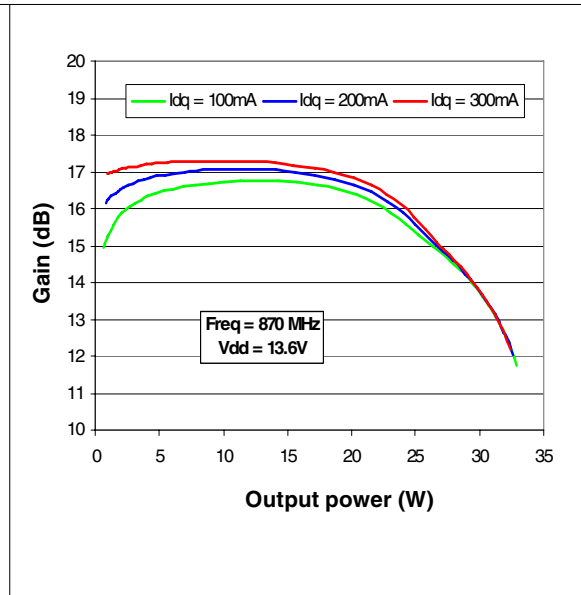

Figure 8. Output power and efficiency vs input power

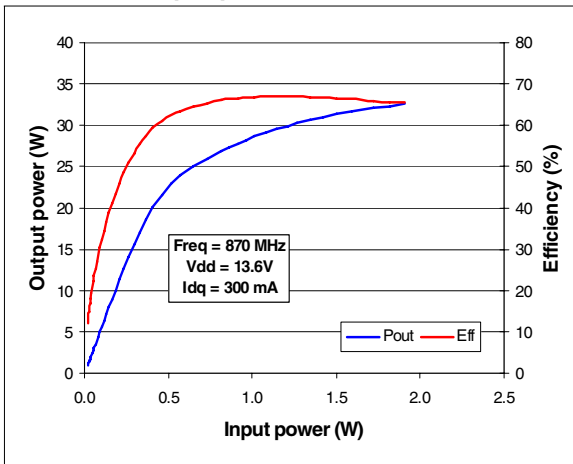

Figure 9. Output power and drain current vs gate voltage

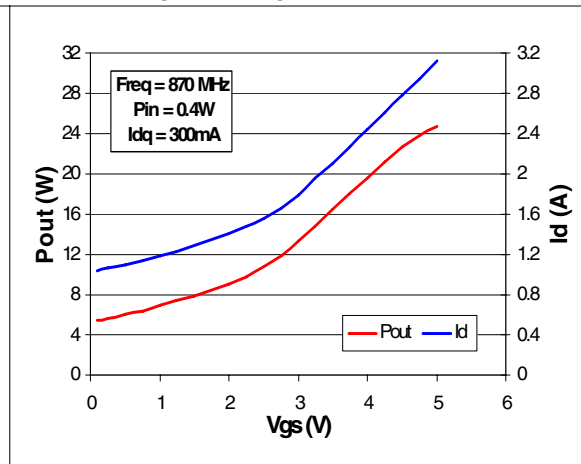

Figure 10. Pout and drain current vs supply voltage ($P_{in} = 0.4\text{ W}$)

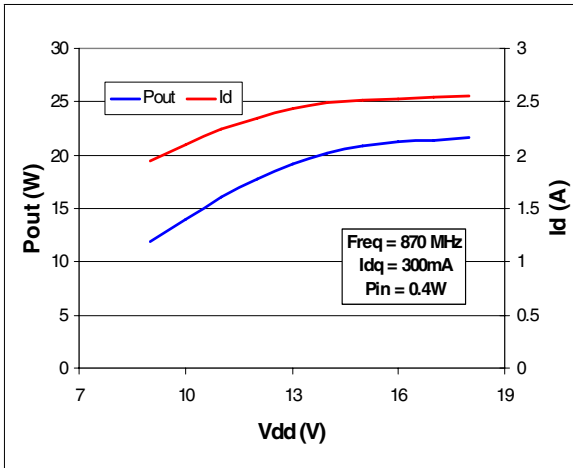
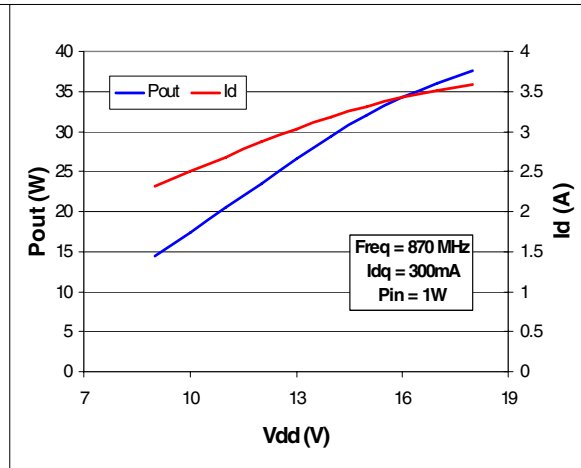

Figure 11. Pout and drain current vs supply voltage ($P_{in} = 1\text{ W}$)



5 ECOPACK®

In order to meet environmental requirements, ST offers these devices in different grades of ECOPACK® packages, depending on their level of environmental compliance. ECOPACK® specifications, grade definitions and product status are available at: www.st.com. ECOPACK® is an ST trademark.

Table 8. STAP1 mechanical data

Dim.	mm.		Inch	
	Min	Max	Min	Max
A	5.40	5.65	0.212	0.222
B	9.27	9.53	0.365	0.375
B1	2.90	3.10	0.114	0.122
B2	15.10	15.65	0.594	0.616
C	6.60	6.99	0.260	0.275
D	23.11	23.42	0.910	0.922
D1	14.88	15.19	0.586	0.598
D2	7.52	7.82	0.296	0.308
E	7.42	7.57	0.292	0.298
E1	5.69	5.84	0.224	0.230
F	0.21	0.31	0.008	0.012
G	1.62	1.72	0.064	0.068
Q	3.15	3.30	0.124	0.130
R1	1.52		0.060	
R2	0.64		0.025	

Figure 12. Package dimensions

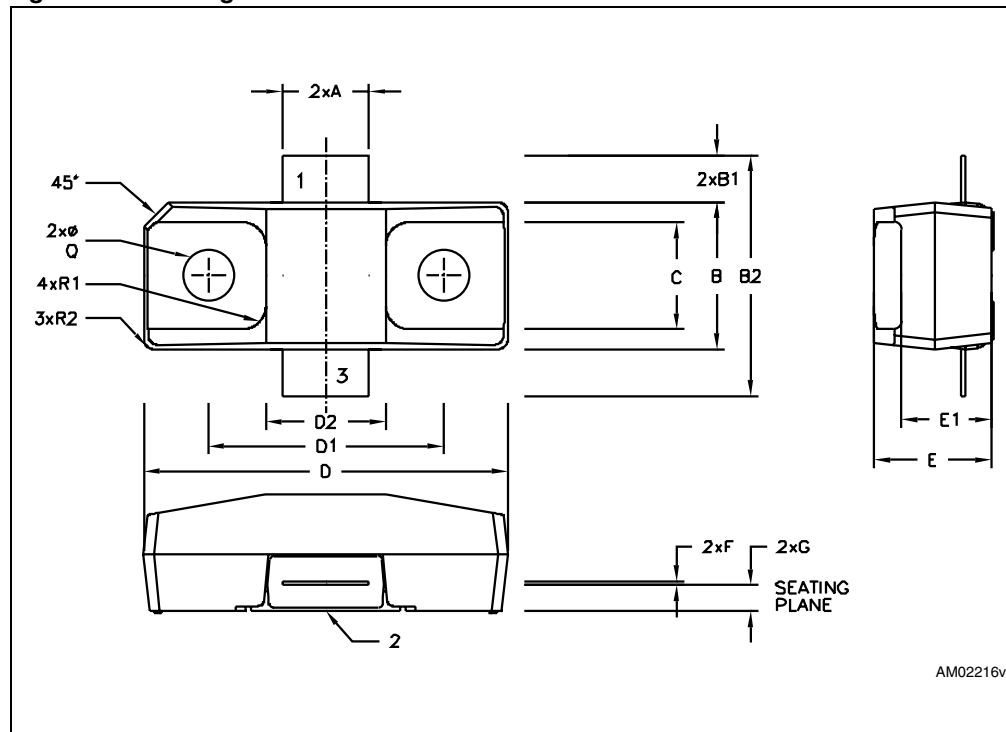

6 Revision history

Table 9. Document revision history

Date	Revision	Changes
01-Jun-2009	1	Initial release
02-Jul-2009	2	Deleted moisture sensitivity level table on page 4

Please Read Carefully:

Information in this document is provided solely in connection with ST products. STMicroelectronics NV and its subsidiaries ("ST") reserve the right to make changes, corrections, modifications or improvements, to this document, and the products and services described herein at any time, without notice.

All ST products are sold pursuant to ST's terms and conditions of sale.

Purchasers are solely responsible for the choice, selection and use of the ST products and services described herein, and ST assumes no liability whatsoever relating to the choice, selection or use of the ST products and services described herein.

No license, express or implied, by estoppel or otherwise, to any intellectual property rights is granted under this document. If any part of this document refers to any third party products or services it shall not be deemed a license grant by ST for the use of such third party products or services, or any intellectual property contained therein or considered as a warranty covering the use in any manner whatsoever of such third party products or services or any intellectual property contained therein.

UNLESS OTHERWISE SET FORTH IN ST'S TERMS AND CONDITIONS OF SALE ST DISCLAIMS ANY EXPRESS OR IMPLIED WARRANTY WITH RESPECT TO THE USE AND/OR SALE OF ST PRODUCTS INCLUDING WITHOUT LIMITATION IMPLIED WARRANTIES OF MERCHANTABILITY, FITNESS FOR A PARTICULAR PURPOSE (AND THEIR EQUIVALENTS UNDER THE LAWS OF ANY JURISDICTION), OR INFRINGEMENT OF ANY PATENT, COPYRIGHT OR OTHER INTELLECTUAL PROPERTY RIGHT.

UNLESS EXPRESSLY APPROVED IN WRITING BY AN AUTHORIZED ST REPRESENTATIVE, ST PRODUCTS ARE NOT RECOMMENDED, AUTHORIZED OR WARRANTED FOR USE IN MILITARY, AIR CRAFT, SPACE, LIFE SAVING, OR LIFE SUSTAINING APPLICATIONS, NOR IN PRODUCTS OR SYSTEMS WHERE FAILURE OR MALFUNCTION MAY RESULT IN PERSONAL INJURY, DEATH, OR SEVERE PROPERTY OR ENVIRONMENTAL DAMAGE. ST PRODUCTS WHICH ARE NOT SPECIFIED AS "AUTOMOTIVE GRADE" MAY ONLY BE USED IN AUTOMOTIVE APPLICATIONS AT USER'S OWN RISK.

Resale of ST products with provisions different from the statements and/or technical features set forth in this document shall immediately void any warranty granted by ST for the ST product or service described herein and shall not create or extend in any manner whatsoever, any liability of ST.

ST and the ST logo are trademarks or registered trademarks of ST in various countries.

Information in this document supersedes and replaces all information previously supplied.

The ST logo is a registered trademark of STMicroelectronics. All other names are the property of their respective owners.

© 2009 STMicroelectronics - All rights reserved

STMicroelectronics group of companies

Australia - Belgium - Brazil - Canada - China - Czech Republic - Finland - France - Germany - Hong Kong - India - Israel - Italy - Japan - Malaysia - Malta - Morocco - Philippines - Singapore - Spain - Sweden - Switzerland - United Kingdom - United States of America

www.st.com