



BUL742C BULB742C

High voltage fast-switching NPN power transistor

Features

- Low spread of dynamic parameters
- High voltage capability
- Minimum lot-to-lot spread for reliable operation
- Very high switching speed

Applications

- Electronic ballast for fluorescent lighting
- Switch mode power supplies

Description

The devices are manufactured using high voltage multi-epitaxial planar technology for high switching speeds and high voltage capability. Thanks to an increased intermediate layer, it has an intrinsic ruggedness which enables the transistor to withstand an high collector current level during breakdown condition, without using the transil protection usually necessary in typical converters for lamp ballast.

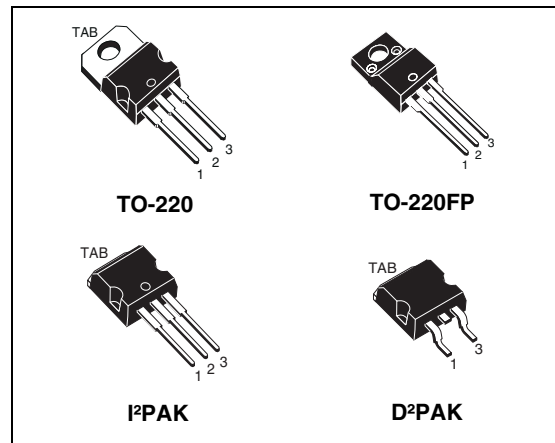

Figure 1. Internal schematic diagram

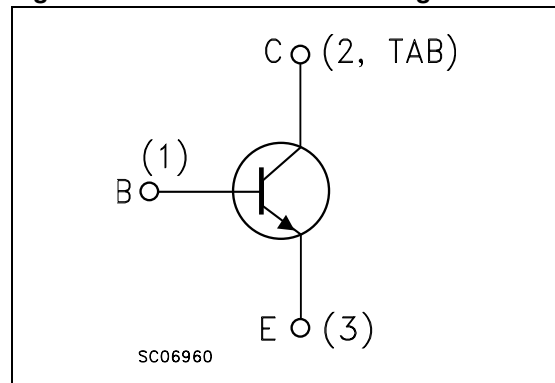

Table 1. Device summary

Order codes	Markings	Packages	Packaging
BUL742C	BUL742C	TO-220	Tube
BUL742CFP	BUL742CFP	TO-220FP	
BULB742C-1	BULB742C	I ² PAK	
BULB742CT4	BULB742C	D ² PAK	Tape and reel

1 Electrical ratings

Table 2. Absolute maximum ratings

Symbol	Parameter	TO-220 / D ² PAK / I ² PAK	TO-220FP	Unit
V _{CES}	Collector-emitter voltage (V _{BE} = 0)	1050		V
V _{CEO}	Collector-emitter voltage (I _B = 0)	400		V
V _{EBO}	Emitter-base voltage (I _C = 0, I _B = 2 A, t _p < 10 ms)	V _{(BR)EBO}		V
I _C	Collector current	4		A
I _{CM}	Collector peak current (t _p < 5 ms)	8		A
I _B	Base current	2		A
I _{BM}	Base peak current (t _p < 5 ms)	4		A
P _{TOT}	Total dissipation at T _c = 25 °C	70	30	W
T _{STG}	Storage temperature	-65 to 150		°C
V _{ISO}	Isolation withstand voltage (RMS) from all three leads to external heatsink		1500	V
T _J	Max. operating junction temperature	150		°C

Table 3. Thermal data

Symbol	Parameter	TO-220/D ² PAK/I ² PAK	TO-220FP	Unit
R _{thJC}	Thermal resistance junction - case	1.79	4.17	°C/W
R _{thJA}	Thermal resistance junction - ambient	62.5	62.5	°C/W

2 Electrical characteristics

$T_{\text{case}} = 25^{\circ}\text{C}$ unless otherwise specified.

Table 4. Electrical characteristics

Symbol	Parameter	Test conditions	Min.	Typ.	Max.	Unit
I_{CES}	Collector cut-off current ($V_{\text{BE}} = 0$)	$V_{\text{CE}} = 1050 \text{ V}$		0.2	10	μA
I_{CEO}	Collector cut-off current ($I_{\text{B}} = 0$)	$V_{\text{CE}} = 400 \text{ V}$		10	250	μA
$V_{(\text{BR})\text{EBO}}$	Emitter base breakdown voltage ($I_{\text{C}} = 0$)	$I_{\text{E}} = 1 \text{ mA}$	15	19	24	V
$V_{\text{CEO(sus)}}^{(1)}$	Collector-emitter sustaining voltage ($I_{\text{B}} = 0$)	$I_{\text{C}} = 10 \text{ mA}$	400	450		V
$V_{\text{CE(sat)}}^{(1)}$	Collector-emitter saturation voltage	$I_{\text{C}} = 1 \text{ A}$ $I_{\text{B}} = 0.2 \text{ A}$ $I_{\text{C}} = 3.5 \text{ A}$ $I_{\text{B}} = 1 \text{ A}$		0.15 0.6	0.5 1.5	V V
$V_{\text{BE(sat)}}^{(1)}$	Base-emitter saturation voltage	$I_{\text{C}} = 3.5 \text{ A}$ $I_{\text{B}} = 1 \text{ A}$		1.1	1.5	V
$h_{\text{FE}}^{(1)}$	DC current gain	$I_{\text{C}} = 0.1 \text{ A}$ $V_{\text{CE}} = 5 \text{ V}$ $I_{\text{C}} = 0.8 \text{ A}$ $V_{\text{CE}} = 3 \text{ V}$	48 25	75 35	100 50	
t_{s} t_{f}	Resistive load Storage time Fall time	$I_{\text{C}} = 2 \text{ A}$ $V_{\text{CC}} = 125 \text{ V}$ $I_{\text{B1}} = - I_{\text{B2}} = 400 \text{ mA}$ $t_{\text{p}} = 300 \mu\text{s}$ $V_{\text{BE(off)}} = -5 \text{ V}$		2.4 350	3.5 500	μs ns
E_{ar}	Repetitive avalanche energy	$L = 2 \text{ mH}$ $C = 1.8 \text{ nF}$ $V_{\text{BE(off)}} = -5 \text{ V}$	6			mJ

1. Pulse test: pulse duration $\leq 300 \mu\text{s}$, duty cycle $\leq 2\%$.

2.1 Electrical characteristics (curves)

Figure 2. Safe operating area for TO-220/I²PAK/D²PAK

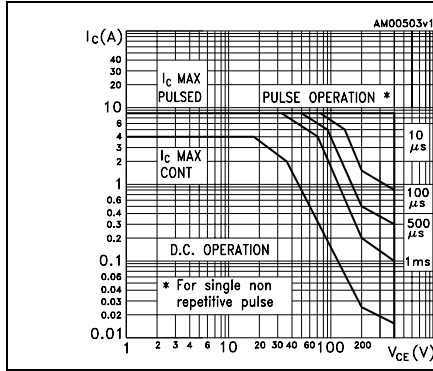

Figure 3. Safe operating area for TO-220FP

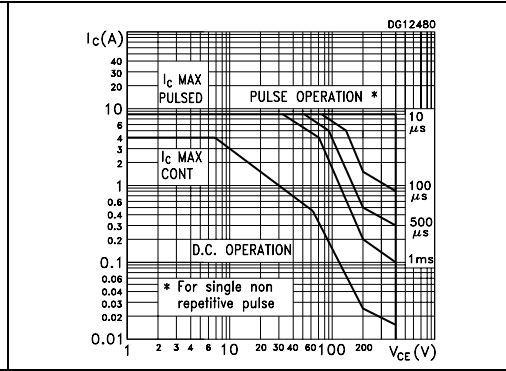

Figure 4. Derating curve



Figure 5. Output characteristics

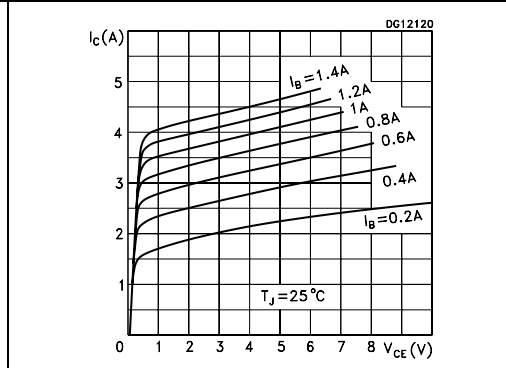

Figure 6. DC current gain (V_{CE} = 3 V)

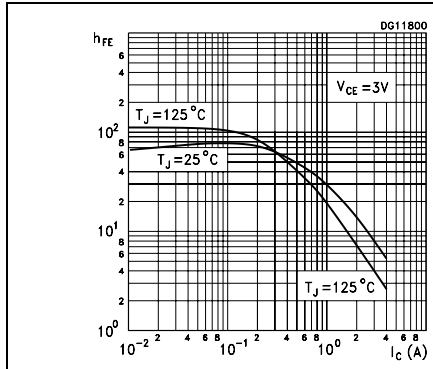

Figure 7. DC current gain (V_{CE} = 5 V)

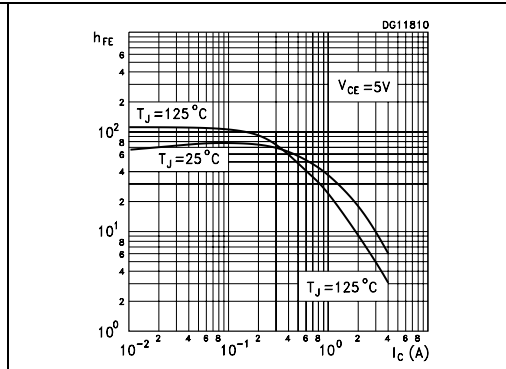

Figure 8. Collector - emitter saturation voltage **Figure 9. Base-emitter saturation voltage**

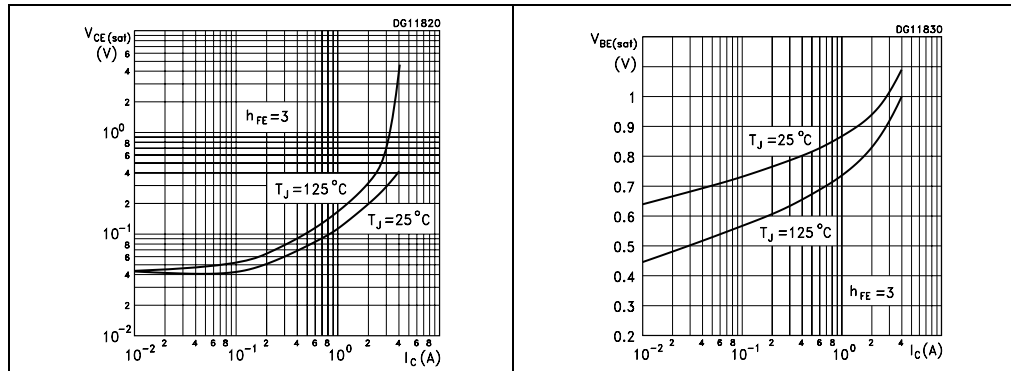

Figure 10. Resistive load switching on times ($h_{FE} = 5$) **Figure 11. Resistive load switching off times ($h_{FE} = 5$)**

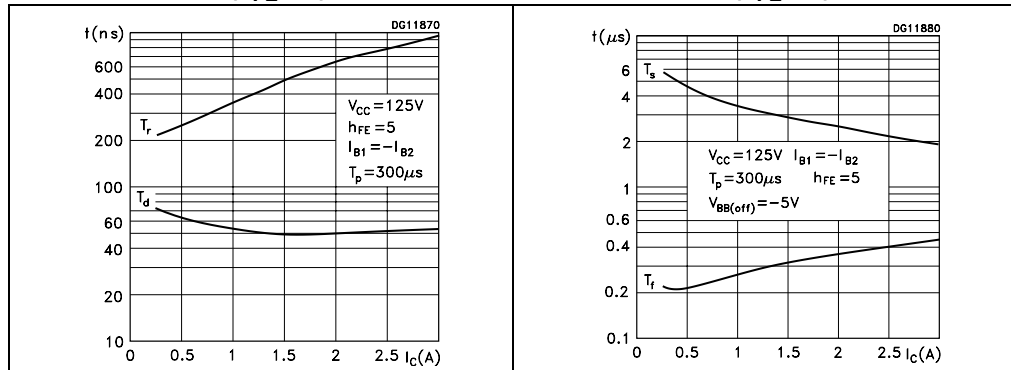

Figure 12. Resistive load switching on times ($h_{FE} = 10$) **Figure 13. Resistive load switching off times ($h_{FE} = 10$)**

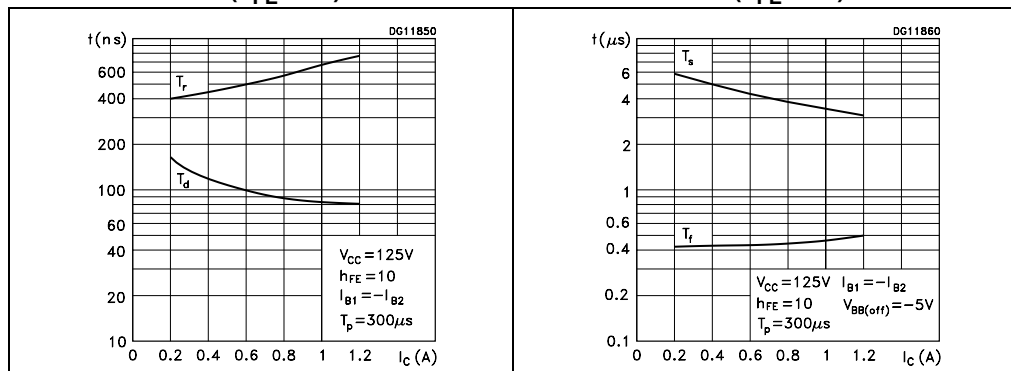
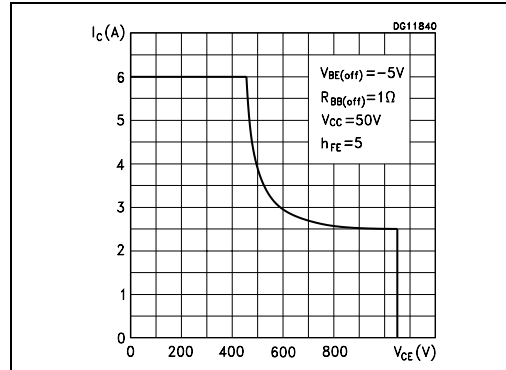

Figure 14. Reverse biased SOA



3 Test circuit

Figure 15. Energy rating test circuit

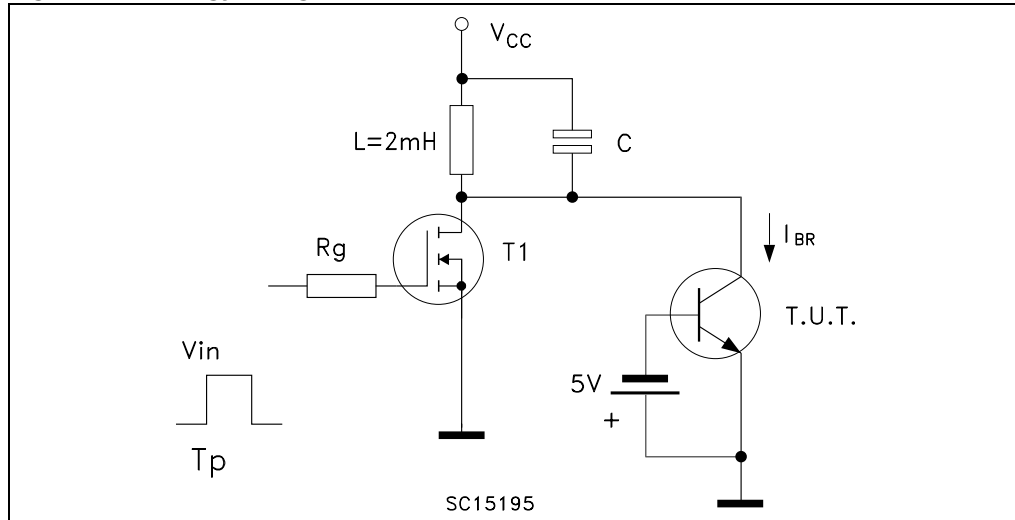
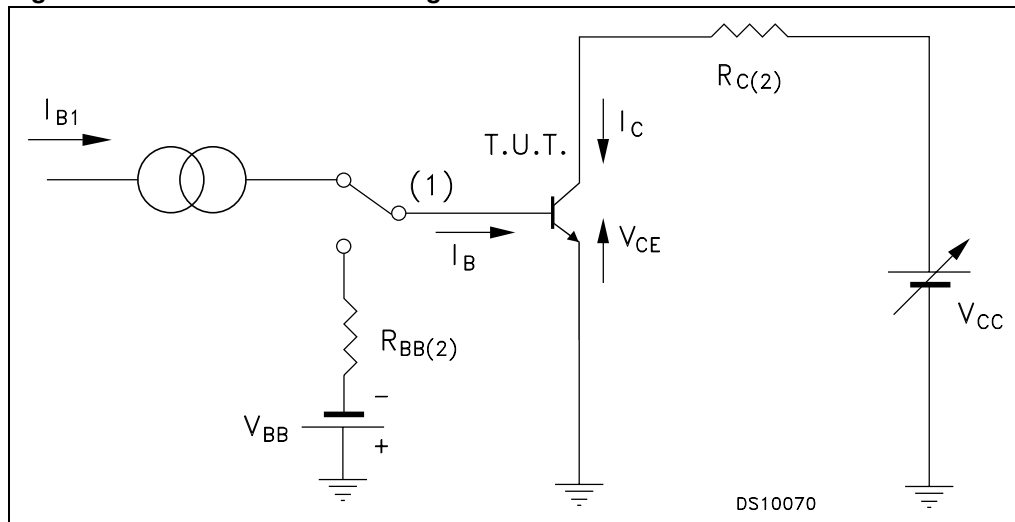

Figure 16. Resistive load switching test circuit



4 Package mechanical data

In order to meet environmental requirements, ST offers these devices in different grades of ECOPACK[®] packages, depending on their level of environmental compliance. ECOPACK[®] specifications, grade definitions and product status are available at: www.st.com. ECOPACK[®] is an ST trademark.

TO-220 type A mechanical data

Dim	mm		
	Min	Typ	Max
A	4.40		4.60
b	0.61		0.88
b1	1.14		1.70
c	0.48		0.70
D	15.25		15.75
D1		1.27	
E	10		10.40
e	2.40		2.70
e1	4.95		5.15
F	1.23		1.32
H1	6.20		6.60
J1	2.40		2.72
L	13		14
L1	3.50		3.93
L20		16.40	
L30		28.90	
∅P	3.75		3.85
Q	2.65		2.95

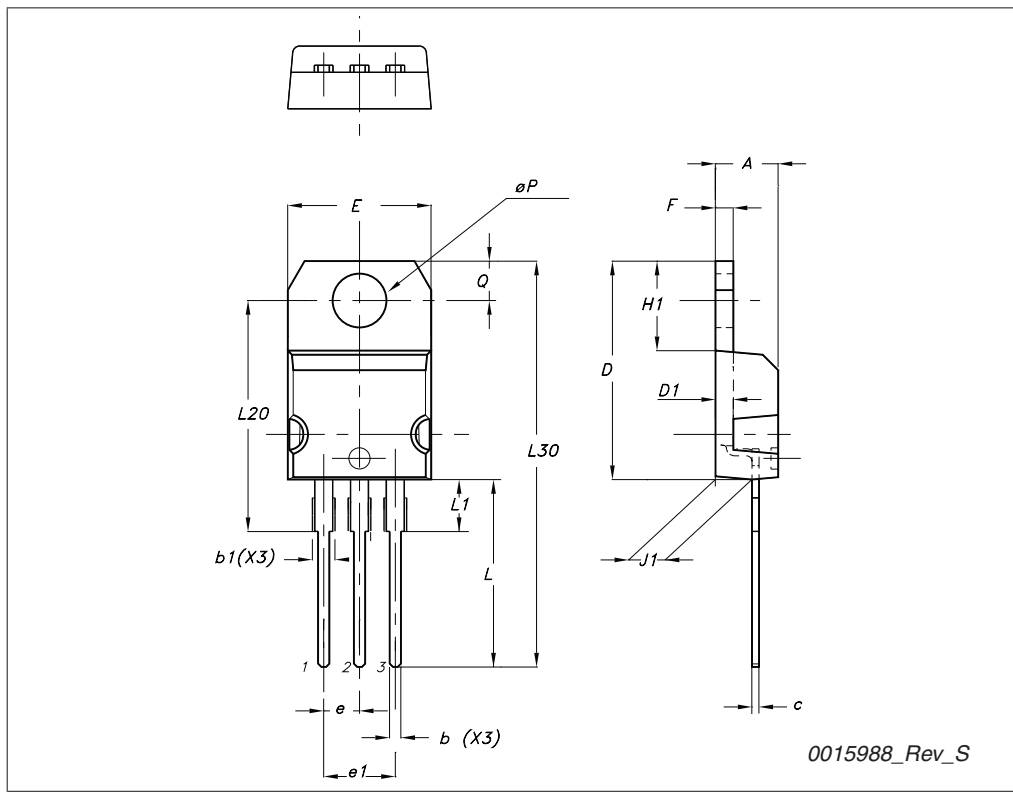

I²PAK (TO-262) mechanical data

Dim	mm			inch		
	Min	Typ	Max	Min	Typ	Max
A	4.40		4.60	0.173		0.181
A1	2.40		2.72	0.094		0.107
b	0.61		0.88	0.024		0.034
b1	1.14		1.70	0.044		0.066
c	0.49		0.70	0.019		0.027
c2	1.23		1.32	0.048		0.052
D	8.95		9.35	0.352		0.368
e	2.40		2.70	0.094		0.106
e1	4.95		5.15	0.194		0.202
E	10		10.40	0.393		0.410
L	13		14	0.511		0.551
L1	3.50		3.93	0.137		0.154
L2	1.27		1.40	0.050		0.055

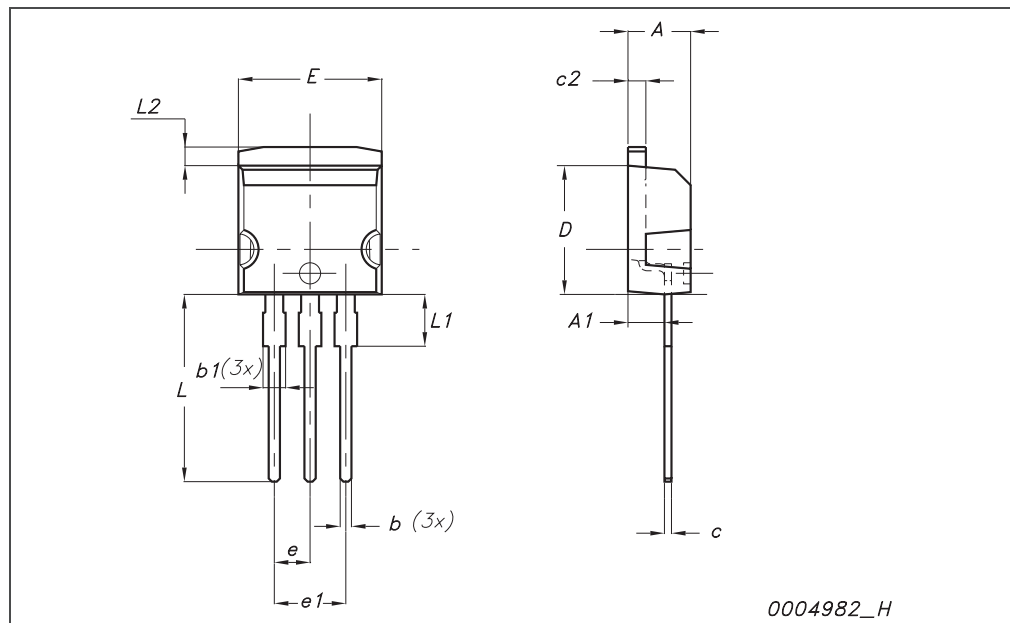
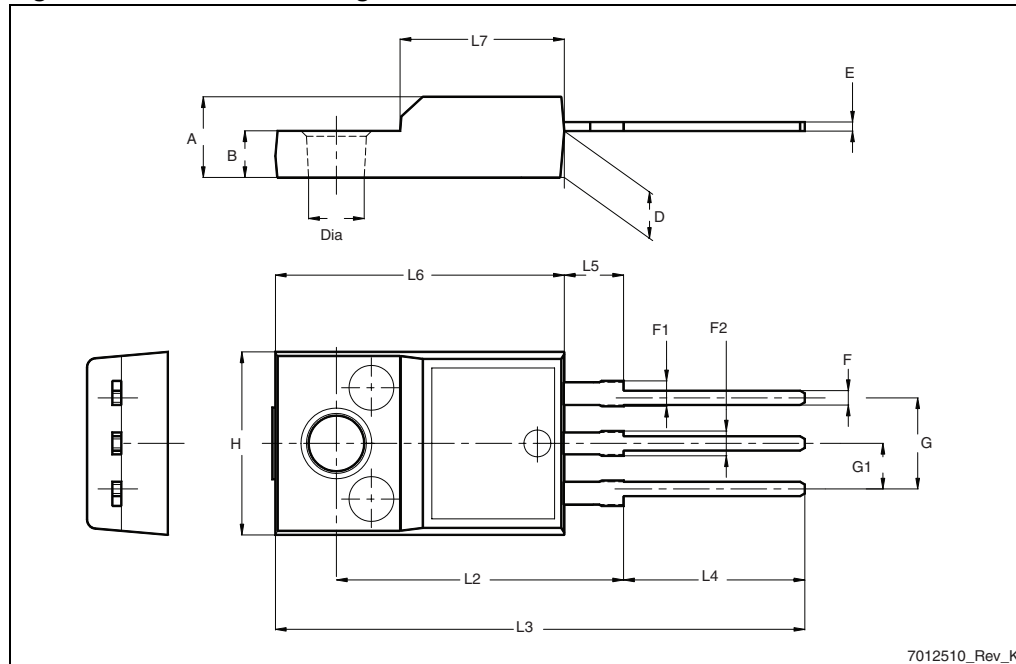

Table 5. TO-220FP mechanical data

Dim.	mm.		
	Min.	Typ.	Max.
A	4.4		4.6
B	2.5		2.7
D	2.5		2.75
E	0.45		0.7
F	0.75		1
F1	1.15		1.70
F2	1.15		1.70
G	4.95		5.2
G1	2.4		2.7
H	10		10.4
L2		16	
L3	28.6		30.6
L4	9.8		10.6
L5	2.9		3.6
L6	15.9		16.4
L7	9		9.3
Dia	3		3.2

Figure 17. TO-220FP drawing



D²PAK (TO-263) mechanical data

Dim.	mm.		
	Min.	Typ.	Max.
A	4.40		4.60
A1	0.03		0.23
b	0.70		0.93
b2	1.14		1.70
c	0.45		0.60
c2	1.23		1.36
D	8.95		9.35
D1	7.50		
E	10		10.40
E1	8.50		
e		2.54	
e1	4.88		5.28
H	15		15.85
J1	2.49		2.69
L	2.29		2.79
L1	1.27		1.40
L2	1.30		1.75
R		0.4	
V2	0°		8°

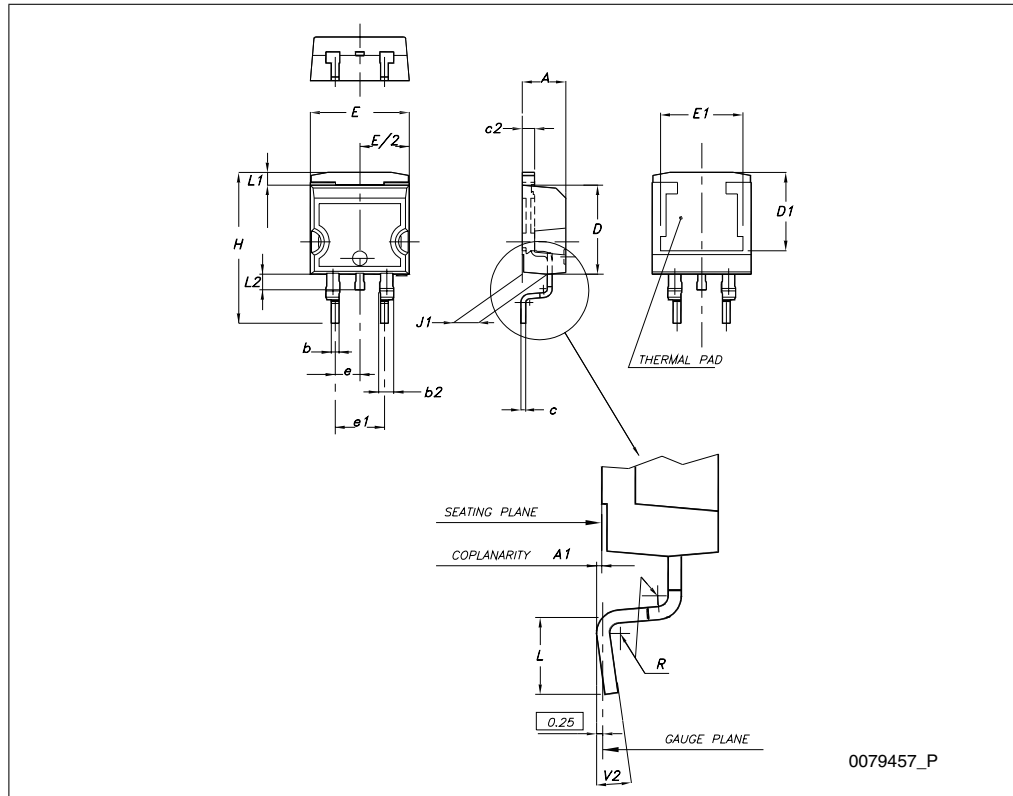

5 Revision history

Table 6. Document revision history

Date	Revision	Changes
21-Jun-2004	1	First release
10-Aug-2007	2	No content changes, document reformatted
27-May-2008	3	Added I ² PAK package
30-Nov-2010	4	Added TO-220FP and D ² PAK packages

Please Read Carefully:

Information in this document is provided solely in connection with ST products. STMicroelectronics NV and its subsidiaries ("ST") reserve the right to make changes, corrections, modifications or improvements, to this document, and the products and services described herein at any time, without notice.

All ST products are sold pursuant to ST's terms and conditions of sale.

Purchasers are solely responsible for the choice, selection and use of the ST products and services described herein, and ST assumes no liability whatsoever relating to the choice, selection or use of the ST products and services described herein.

No license, express or implied, by estoppel or otherwise, to any intellectual property rights is granted under this document. If any part of this document refers to any third party products or services it shall not be deemed a license grant by ST for the use of such third party products or services, or any intellectual property contained therein or considered as a warranty covering the use in any manner whatsoever of such third party products or services or any intellectual property contained therein.

UNLESS OTHERWISE SET FORTH IN ST'S TERMS AND CONDITIONS OF SALE ST DISCLAIMS ANY EXPRESS OR IMPLIED WARRANTY WITH RESPECT TO THE USE AND/OR SALE OF ST PRODUCTS INCLUDING WITHOUT LIMITATION IMPLIED WARRANTIES OF MERCHANTABILITY, FITNESS FOR A PARTICULAR PURPOSE (AND THEIR EQUIVALENTS UNDER THE LAWS OF ANY JURISDICTION), OR INFRINGEMENT OF ANY PATENT, COPYRIGHT OR OTHER INTELLECTUAL PROPERTY RIGHT.

UNLESS EXPRESSLY APPROVED IN WRITING BY AN AUTHORIZED ST REPRESENTATIVE, ST PRODUCTS ARE NOT RECOMMENDED, AUTHORIZED OR WARRANTED FOR USE IN MILITARY, AIR CRAFT, SPACE, LIFE SAVING, OR LIFE SUSTAINING APPLICATIONS, NOR IN PRODUCTS OR SYSTEMS WHERE FAILURE OR MALFUNCTION MAY RESULT IN PERSONAL INJURY, DEATH, OR SEVERE PROPERTY OR ENVIRONMENTAL DAMAGE. ST PRODUCTS WHICH ARE NOT SPECIFIED AS "AUTOMOTIVE GRADE" MAY ONLY BE USED IN AUTOMOTIVE APPLICATIONS AT USER'S OWN RISK.

Resale of ST products with provisions different from the statements and/or technical features set forth in this document shall immediately void any warranty granted by ST for the ST product or service described herein and shall not create or extend in any manner whatsoever, any liability of ST.

ST and the ST logo are trademarks or registered trademarks of ST in various countries.

Information in this document supersedes and replaces all information previously supplied.

The ST logo is a registered trademark of STMicroelectronics. All other names are the property of their respective owners.

© 2010 STMicroelectronics - All rights reserved

STMicroelectronics group of companies

Australia - Belgium - Brazil - Canada - China - Czech Republic - Finland - France - Germany - Hong Kong - India - Israel - Italy - Japan - Malaysia - Malta - Morocco - Philippines - Singapore - Spain - Sweden - Switzerland - United Kingdom - United States of America

www.st.com