

50 mA, 3 μ A supply current low drop linear regulator

Features

- 2.3 V to 12 V input voltage range
- 50 mA maximum output current
- 3 μ A quiescent current
- Available in 1.8 V, 2.5 V, 3.3 V, 5.0 V and adjustable
- 200 mV dropout voltage at 25 mA output current
- Internal thermal protection
- Available in SOT323-5L package, and SOT23-5L package (upon request)

Applications

- Portable/battery powered equipments
- Electronic sensors
- Microcontroller power
- Real time clock backup power

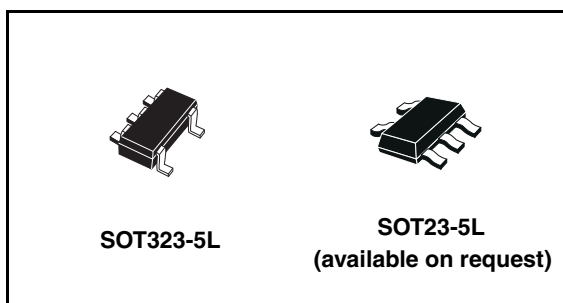

Description

The STLQ50 is a BiCMOS linear regulator specifically designed for operating in environment with very low power consumption constraints.

Due to the very low quiescent current (3 μ A) the device is suitable for those application that have very long stand-by time allowing extension of battery life.

The P-MOS pass element allows also a very good drop-out figure (200 mV at 25 mA I_O and 350 mV at full load) without affecting the consumption characteristics.

Housed in the very small SOT323-5L or SOT23-5L, it fulfils the space saving requirements in battery powered equipments.

Table 1. Device summary

Part number	Order codes		Output voltage
	Packages		
	SOT323-5L (T&R)	SOT23-5L (T&R) ⁽¹⁾	
STLQ50XX18	STLQ50C18R	STLQ50M18R	Fixed $V_O = 1.8V$
STLQ50XX25	STLQ50C25R	STLQ50M25R	Fixed $V_O = 2.5V$
STLQ50XX33	STLQ50C33R	STLQ50M33R	Fixed $V_O = 3.3V$
STLQ50XX50	STLQ50C50R	STLQ50M50R	Fixed $V_O = 5.0V$
STLQ50	STLQ50C-R	STLQ50M-R	Adjustable

1. Available upon request.

Contents

1	Diagram	3
2	Pin configuration	4
3	Maximum ratings	5
4	Electrical characteristics	6
5	Typical application	7
6	Typical characteristics	8
7	Application information	10
	7.1 External components	10
	7.2 Power dissipation	10
	7.3 Protection	11
8	Package mechanical data	12
9	Revision history	17

1 Diagram

Figure 1. Block diagram

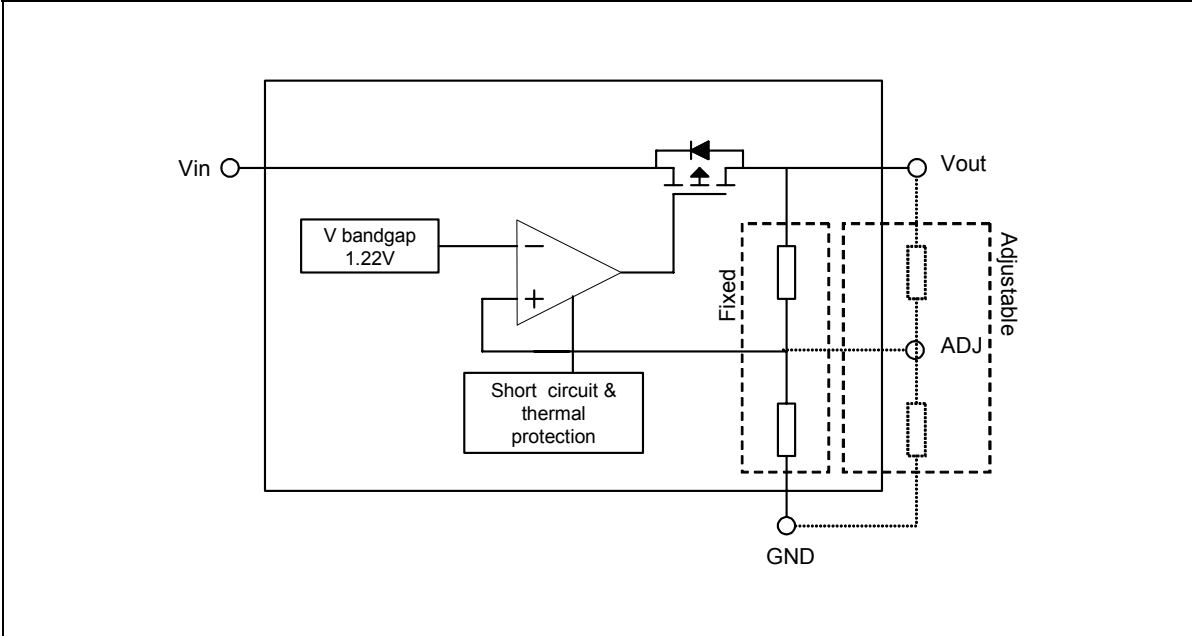

2 Pin configuration

Figure 2. Pin connections (top view)

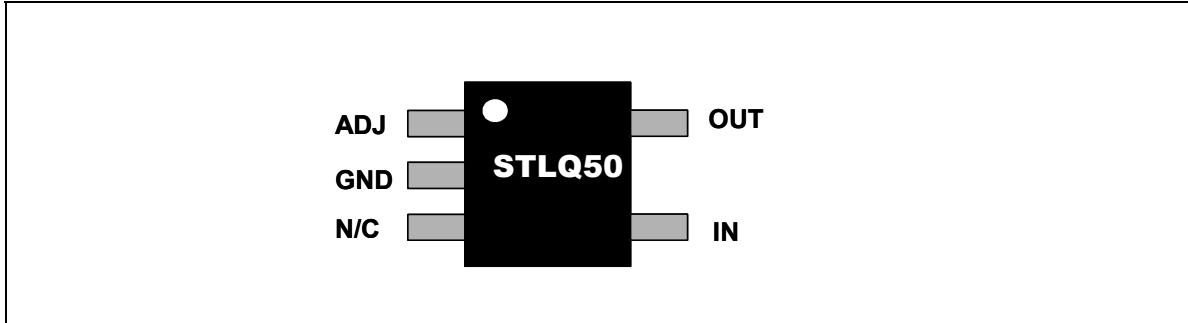

Table 2. Pin description

Pin n°	Symbol	Note
1	ADJ	STLQ50: output voltage adjust
	N/C	STLQ50xx: not connected
2	GND	Ground
3	N/C	Not connected
4	IN	Input voltage
5	OUT	Output voltage

3 Maximum ratings

Table 3. Absolute maximum ratings

Symbol	Parameter	Value	Unit
V _I	DC Input voltage	-0.3 to +14	V
V _{FB}	FB voltage	-0.3 to +7	V
ESD	Human body model (all pins)	±2	kV
T _J	Junction temperature	-40 to 150	°C
T _{STG}	Storage temperature range	-55 to 150	°C

Note: Absolute maximum ratings are those values beyond which damage to the device may occur. Functional operation under these conditions is not implied.

Table 4. Thermal data

Symbol	Parameter	SOT323-5L	SOT23-5L	Unit
R _{thJA}	Thermal resistance junction-ambient	331.4 ⁽¹⁾	191 ⁽¹⁾	°C/W

1. This value is referred to a 4-layer PCB, JEDEC standard test board.

4 Electrical characteristics

Table 5. Electrical characteristics

($V_I = V_{O(NOM)} + 1\text{ V}$ or $V_I = 2.5\text{ V}$ if $V_O + 1.5\text{ V}$; $T_A = -40\text{ °C}$ to 125 °C ; $I_O = 1\text{ mA}$; typical values are at $T_A = 25\text{ °C}$, $C_O = 1\text{ }\mu\text{F}$ unless otherwise specified)

Symbol	Parameter	Test conditions	Min.	Typ.	Max.	Unit
V_I	Input voltage range	$I_O=20\text{mA}$	2.3		12	V
		$I_O=50\text{mA}$	2.5		12	
I_Q	Quiescent current (Measured on ground pin, fixed version)	$V_I=5\text{V}$		3.5	5.0	μA
		$V_I=12\text{V}$		4.1	6.0	
V_O	Output voltage range (STLQ50ADJ)		1.222		11	V
	Accuracy as percentage of nominal voltage at $T_J=25\text{°C}$		-2		+2	%
$V_{DROD-MAX}$	Max dropout voltage ⁽¹⁾	$I_O=50\text{mA}$;		0.4	0.7	V
ΔV_O	Load regulation	$1\text{mA} < I_O < 50\text{mA}$			0.15	%/mA
ΔV_O	Line regulation	$V_O=1.5\text{V}$; $V_O+1\text{V} < V_I < 12\text{V}$; $V_O=1.5\text{V}$; $2.5\text{V} < V_I < 12\text{V}$;			0.3	%/V
SVR	Supply voltage rejection	$V_{RIPPLE} = 0.1\text{V}$, $I_O = 20\text{mA}$ $f=120\text{Hz}$		30		dB
eN	Output noise voltage	B_W from 200KHz to 100KHZ; $I_O=10\text{mA}$		560		μV_{RMS}
Th	Thermal protection			160		$^{\circ}\text{C}$
$I_{O\text{MAX}}$	Maximum output current ⁽²⁾	$V_O=0\text{V}$		500		mA

1. $V_I=2.5\text{V}$ when $V_{O(NOM)} \leq 1.1\text{V}$

2. The maximum power dissipation must not be exceeded, see application information for details.

5 Typical application

Figure 3. Fixed versions: STLQ5018- STLQ5025- STLQ5033- STLQ5050

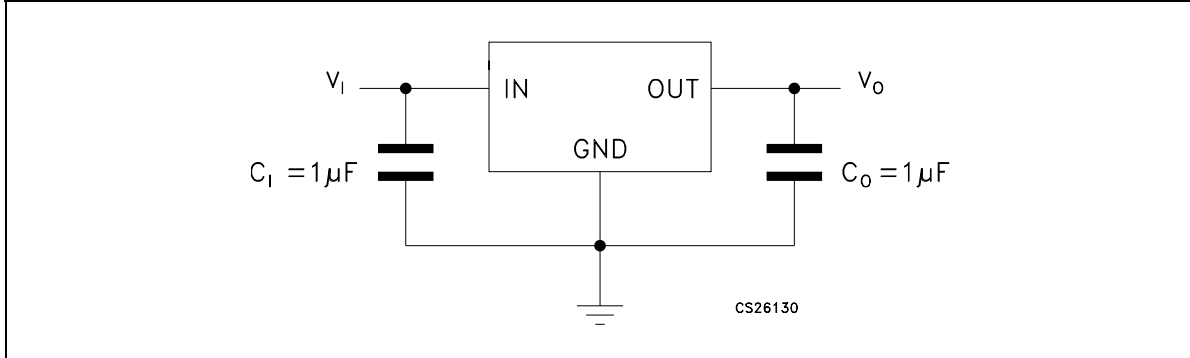
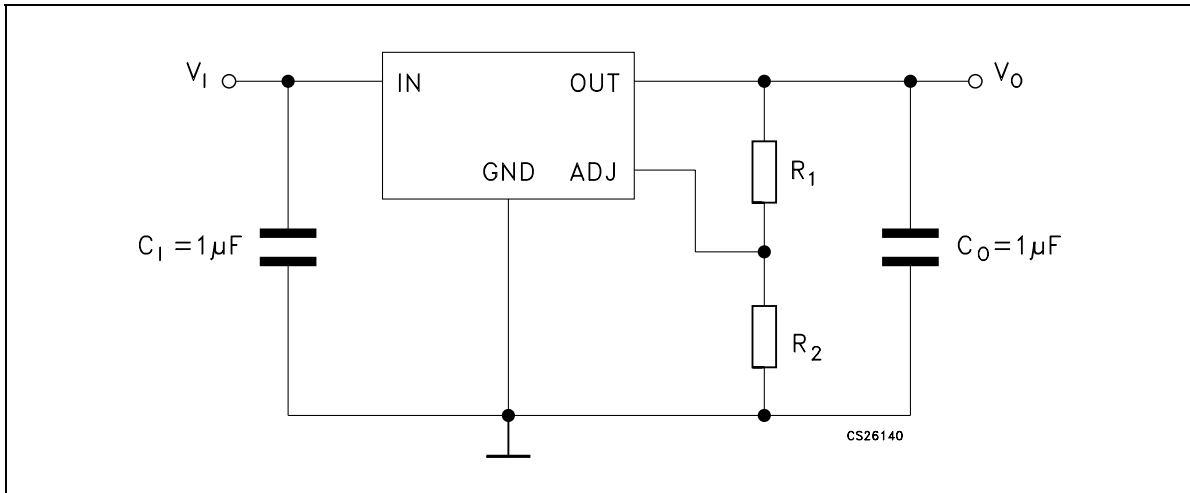

Figure 4. Adjustable version STLQ50ADJ



6 Typical characteristics

Figure 5. V_O vs T_J

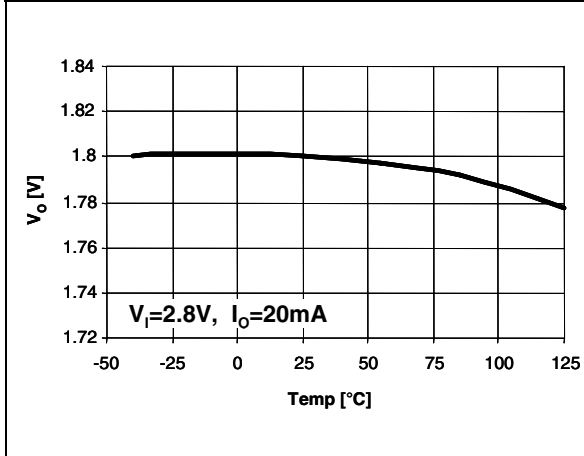

Figure 6. V_O vs V_I

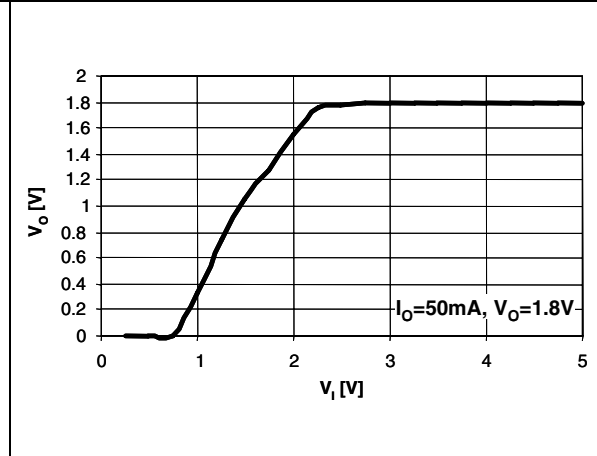

Figure 7. I_Q vs T_J

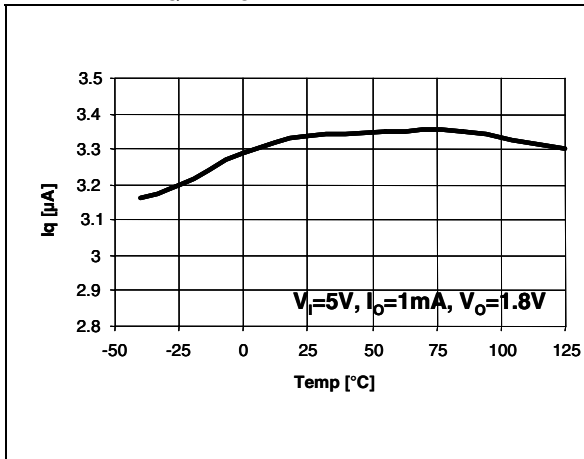

Figure 8. V_{DROD} vs I_O

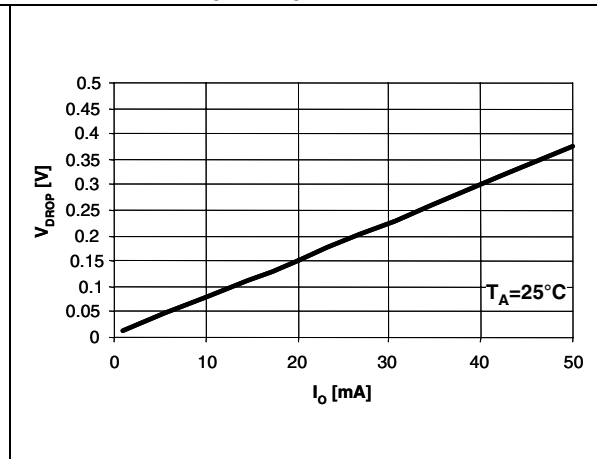

Figure 9. V_{DROD} vs T_J

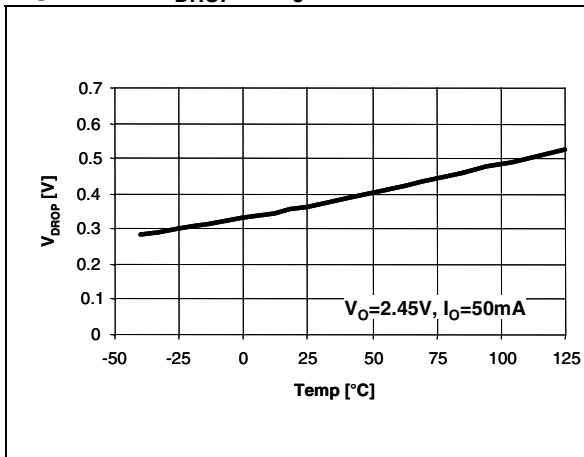

Figure 10. Stability

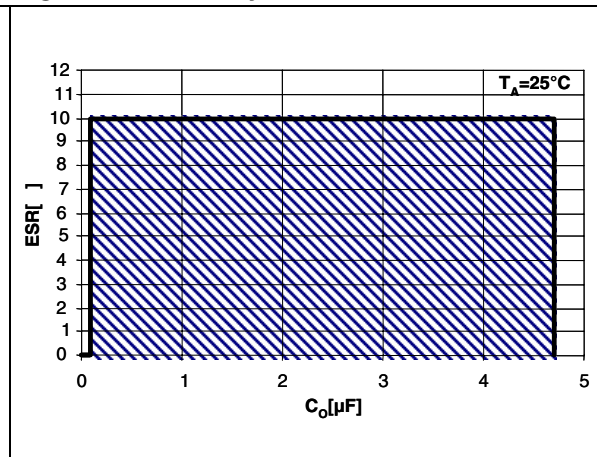

Figure 11. S.V.R. vs Freq.

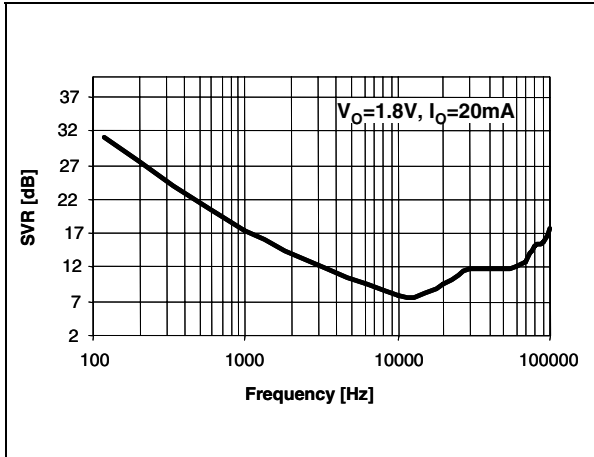

Figure 12. S.V.R. vs I_O

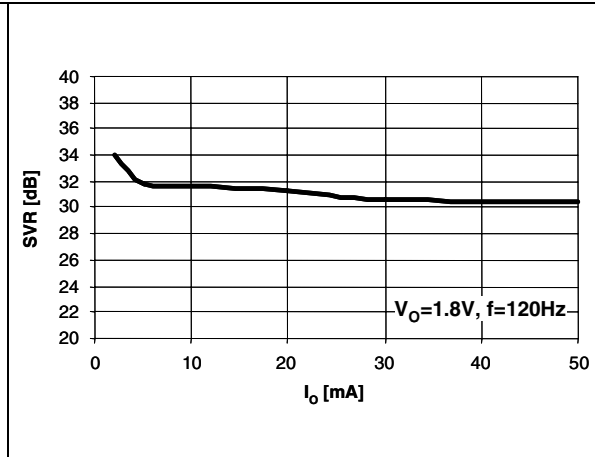

Figure 13. Line transient response

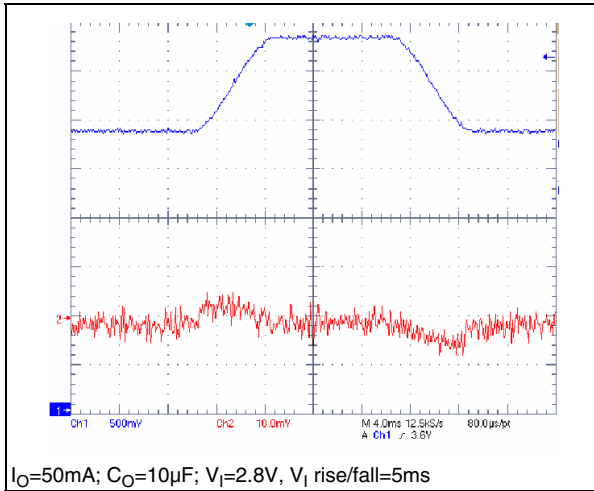

Figure 14. Load transient response

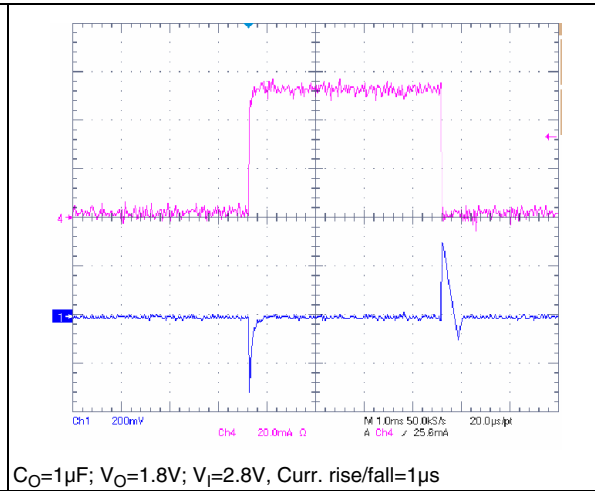

Figure 15. Short circuit current

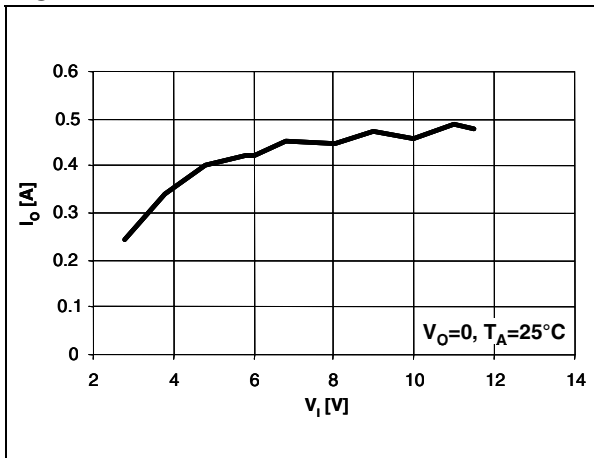
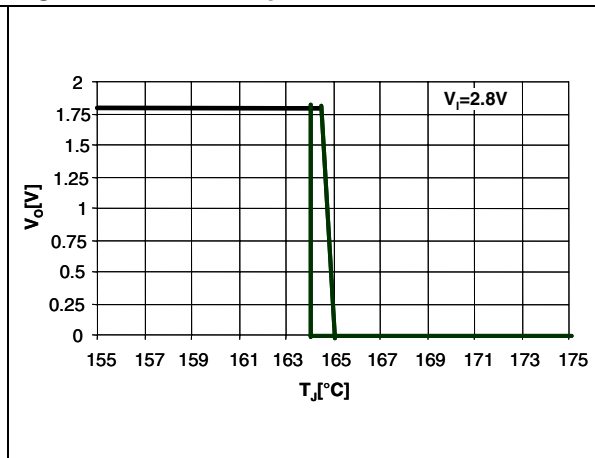

Figure 16. Thermal protection



7 Application information

The STLQ50 is a BiCMOS linear regulator specifically designed for operating in environment with very low power consumption constraints. The very low quiescent current of 3 μA is obtained with use of CMOS technology that makes the device suitable for those application that have very long stand-by time. The very low power consumption allows extending the battery life and the tiny packages (SOT323-5L or SOT23-5L) fulfil the space saving requirements of battery powered equipments. Moreover the STLQ50 provides wide input voltage operation from 2.5 V up to 12 V.

The P-MOS pass element allows also a very good drop-out figure: 0.7 V at full load and at 125 °C without affecting the consumption characteristics.

7.1 External components

The typical application schematic of STLQ50 is shown in [Figure 1 - Figure 2](#), a 1 μF input and output capacitors placed close to the device are needed in order to provide proper operation. The device is stable with electrolytic and ceramic output capacitors having values higher than 1 μF (see figure typical characteristics for stability details).

In the adjustable version (STLQ50) the output voltage is programmed using an external resistor divider as shown in [Figure 2](#). The output voltage can be adjusted from 1.22 to 11 V and it can be calculated using the following formula:

$$V_O = V_{FB} \times (1 + R_1/R_2)$$

where $V_{FB}=1.222$ V is the internal reference voltage;

The sum between R_1 and R_2 resistors should be chosen in order to guarantee 1 μA of divider current at least. Lower value resistors will improve the noise performances but the quiescent current will increase. Higher value resistors should be avoided because the ADJ leakage current will influence the voltage set by the resistor divider making the above formula no more valid.

The suggested design procedure is to choose $R_2 = 1$ M Ω and then calculate R_1 using the following formula: $R_1 = (V_O/V_{FB}-1) \times R_2$

7.2 Power dissipation

In order to ensure proper operation, the STLQ50 junction temperature should never exceed 125 °C, this limits the maximum power dissipation the regulator can sustain in any application. The maximum power dissipation can be calculated as:

$$P_{D\text{MAX}} = (T_{J\text{MAX}} - T_A)/R_{thJA}$$

where $T_{J\text{MAX}} = 125$ °C;

T_A is the ambient temperature;

R_{thJA} is the junction to ambient thermal resistance of the package (see [Table 4](#) thermal data).

The power dissipation can be calculated simply as:

$$P_D = (V_I - V_O) \times I_O$$

In every application condition, P_D must be lower than $P_{D\text{MAX}}$.

7.3 Protection

The P-MOS pass element has an internal diode with anode connected to V_O and cathode to V_I . In case $V_O > V_I$ the current will flow from output to the input without any limitation. In this case proper limiting network is recommended.

The current limitation is automatically provided by the characteristics of the PMOS pass element (see typical characteristics), so the short circuit current is dependent on the input voltage. When considering the short circuit current take care, in any case, to not exceed the maximum power dissipation sustainable by the device.

The STLQ50 features an internal thermal protection that linearly reduces the output current when the internal temperature increases, consequently, at a given load, also the output voltage decreases. The action of the thermal protection starts at 125 °C when the output voltage slightly decreases, while close to 163 °C the output voltage drops to 0 V. Since this is a linear control, sudden over current conditions can quickly rise the chip temperature without time for the thermal protection to act, so it cannot be used as a limitation for the output current.

8 Package mechanical data

In order to meet environmental requirements, ST offers these devices in ECOPACK[®] packages. These packages have a lead-free second level interconnect. The category of second Level Interconnect is marked on the package and on the inner box label, in compliance with JEDEC Standard JESD97. The maximum ratings related to soldering conditions are also marked on the inner box label. ECOPACK is an ST trademark. ECOPACK specifications are available at: www.st.com.

SOT323-5L mechanical data

Dim.	mm.			mils.		
	Min.	Typ.	Max.	Min.	Typ.	Max.
A	0.80		1.10	31.5		43.3
A1	0.00		0.10	0.0		3.9
A2	0.80		1.00	31.5		39.4
b	0.15		0.30	5.9		11.8
C	0.10		0.18	3.9		7.1
D	1.80		2.20	70.9		86.6
E	1.80		2.40	70.9		94.5
E1	1.15		1.35	45.3		53.1
e		0.65			25.6	
e1		1.3			51.2	
L	0.10		0.30	3.9		11.8

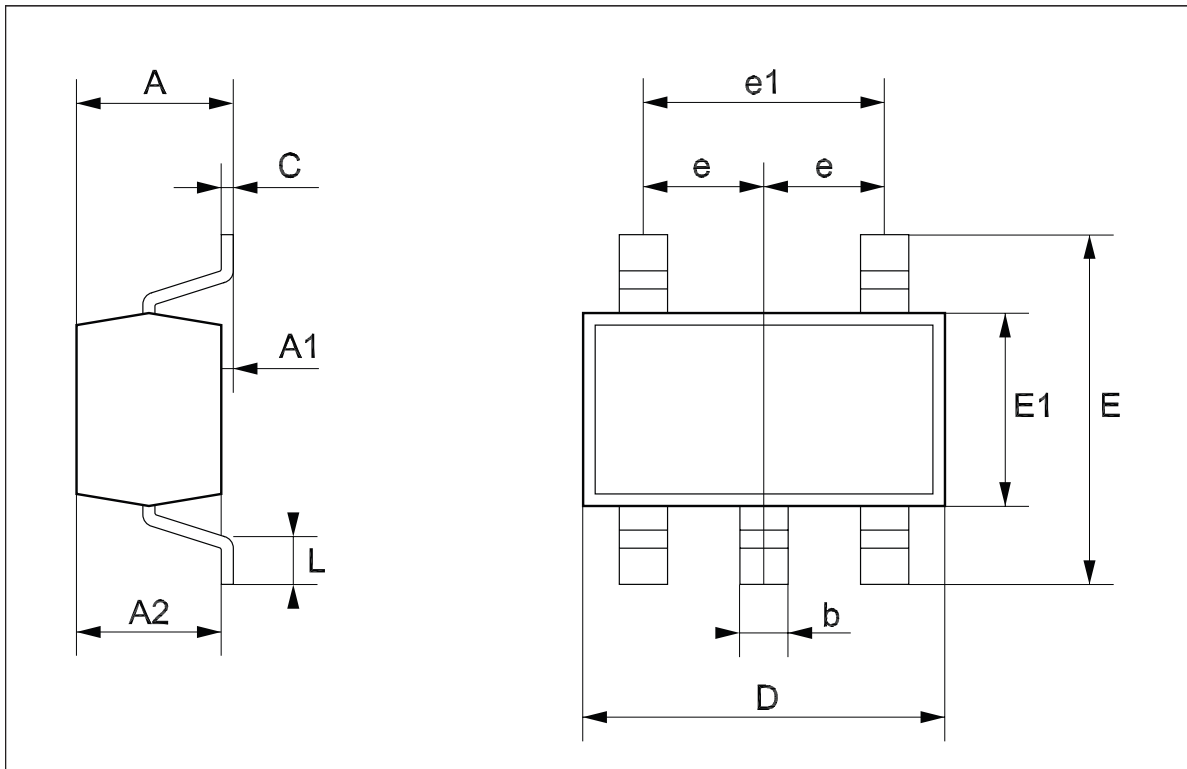

SOT23-5L mechanical data

Dim.	mm.			mils.		
	Min.	Typ.	Max.	Min.	Typ.	Max.
A	0.90		1.45	35.4		57.1
A1	0.00		0.10	0.0		3.9
A2	0.90		1.30	35.4		51.2
b	0.35		0.50	13.7		19.7
C	0.09		0.20	3.5		7.8
D	2.80		3.00	110.2		118.1
E	1.50		1.75	59.0		68.8
e		0.95			37.4	
H	2.60		3.00	102.3		118.1
L	0.10		0.60	3.9		23.6

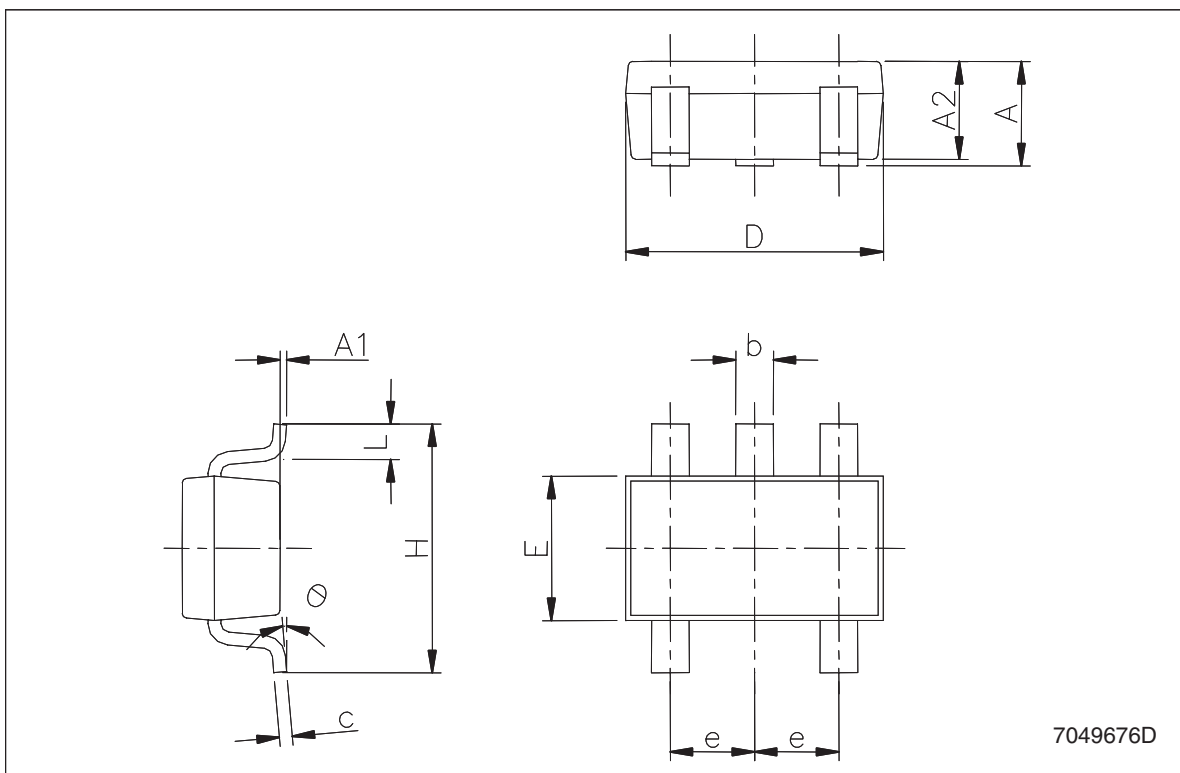

Tape & reel SOT323-xL mechanical data

Dim.	mm.			inch.		
	Min.	Typ.	Max.	Min.	Typ.	Max.
A	175	180	185	6.889	7.086	7.283
C	12.8	13	13.2	0.504	0.512	0.519
D	20.2			0.795		
N	59.5	60	60.5		2.362	
T			14.4			0.567
Ao		2.25			0.088	
Bo		2.7			0.106	
Ko		1.2			0.047	
Po	3.9	4	4.1	0.153	0.157	0.161
P	3.8	4	4.2	0.149	0.157	0.165

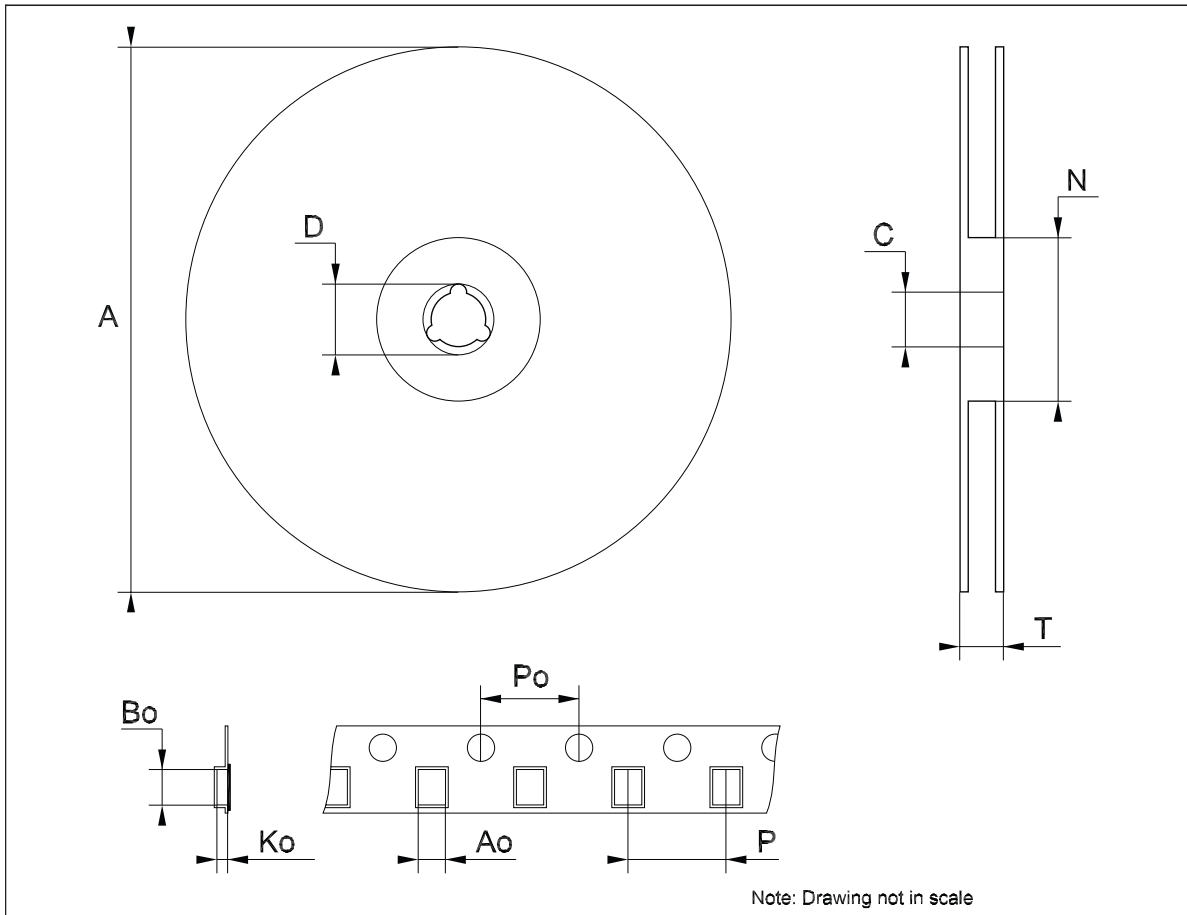

Tape & reel SOT23-xL mechanical data

Dim.	mm.			inch.		
	Min.	Typ.	Max.	Min.	Typ.	Max.
A			180			7.086
C	12.8	13.0	13.2	0.504	0.512	0.519
D	20.2			0.795		
N	60			2.362		
T			14.4			0.567
Ao	3.13	3.23	3.33	0.123	0.127	0.131
Bo	3.07	3.17	3.27	0.120	0.124	0.128
Ko	1.27	1.37	1.47	0.050	0.054	0.058
Po	3.9	4.0	4.1	0.153	0.157	0.161
P	3.9	4.0	4.1	0.153	0.157	0.161

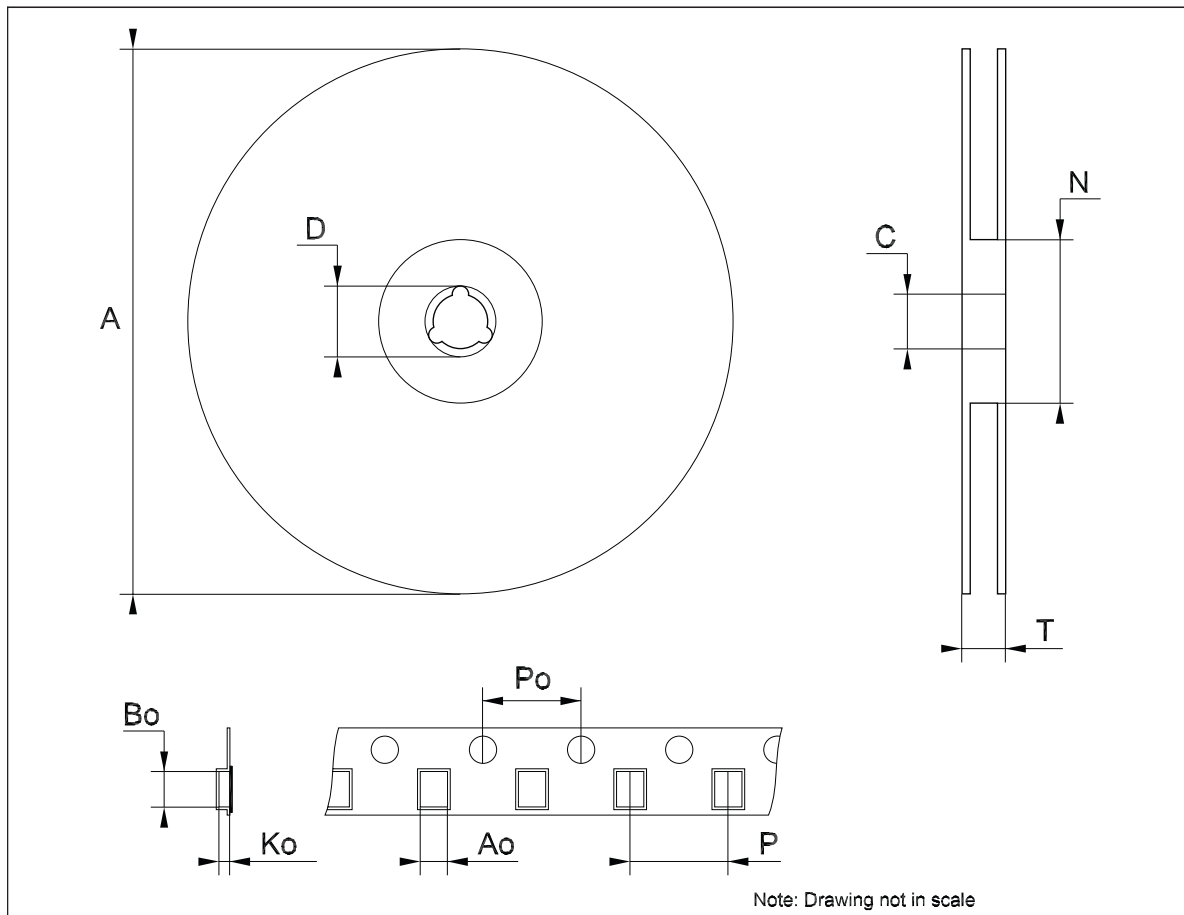

9 Revision history

Table 6. Document revision history

Date	Revision	Changes
07-Feb-2007	1	Initial release.
13-Feb-2007	2	Typo in cover page 350mA ==> 350mV.
06-Jul-2007	3	Added part number.
14-Nov-2007	4	Added Table 1 .

Please Read Carefully:

Information in this document is provided solely in connection with ST products. STMicroelectronics NV and its subsidiaries ("ST") reserve the right to make changes, corrections, modifications or improvements, to this document, and the products and services described herein at any time, without notice.

All ST products are sold pursuant to ST's terms and conditions of sale.

Purchasers are solely responsible for the choice, selection and use of the ST products and services described herein, and ST assumes no liability whatsoever relating to the choice, selection or use of the ST products and services described herein.

No license, express or implied, by estoppel or otherwise, to any intellectual property rights is granted under this document. If any part of this document refers to any third party products or services it shall not be deemed a license grant by ST for the use of such third party products or services, or any intellectual property contained therein or considered as a warranty covering the use in any manner whatsoever of such third party products or services or any intellectual property contained therein.

UNLESS OTHERWISE SET FORTH IN ST'S TERMS AND CONDITIONS OF SALE ST DISCLAIMS ANY EXPRESS OR IMPLIED WARRANTY WITH RESPECT TO THE USE AND/OR SALE OF ST PRODUCTS INCLUDING WITHOUT LIMITATION IMPLIED WARRANTIES OF MERCHANTABILITY, FITNESS FOR A PARTICULAR PURPOSE (AND THEIR EQUIVALENTS UNDER THE LAWS OF ANY JURISDICTION), OR INFRINGEMENT OF ANY PATENT, COPYRIGHT OR OTHER INTELLECTUAL PROPERTY RIGHT.

UNLESS EXPRESSLY APPROVED IN WRITING BY AN AUTHORIZED ST REPRESENTATIVE, ST PRODUCTS ARE NOT RECOMMENDED, AUTHORIZED OR WARRANTED FOR USE IN MILITARY, AIR CRAFT, SPACE, LIFE SAVING, OR LIFE SUSTAINING APPLICATIONS, NOR IN PRODUCTS OR SYSTEMS WHERE FAILURE OR MALFUNCTION MAY RESULT IN PERSONAL INJURY, DEATH, OR SEVERE PROPERTY OR ENVIRONMENTAL DAMAGE. ST PRODUCTS WHICH ARE NOT SPECIFIED AS "AUTOMOTIVE GRADE" MAY ONLY BE USED IN AUTOMOTIVE APPLICATIONS AT USER'S OWN RISK.

Resale of ST products with provisions different from the statements and/or technical features set forth in this document shall immediately void any warranty granted by ST for the ST product or service described herein and shall not create or extend in any manner whatsoever, any liability of ST.

ST and the ST logo are trademarks or registered trademarks of ST in various countries.

Information in this document supersedes and replaces all information previously supplied.

The ST logo is a registered trademark of STMicroelectronics. All other names are the property of their respective owners.

© 2007 STMicroelectronics - All rights reserved

STMicroelectronics group of companies

Australia - Belgium - Brazil - Canada - China - Czech Republic - Finland - France - Germany - Hong Kong - India - Israel - Italy - Japan - Malaysia - Malta - Morocco - Singapore - Spain - Sweden - Switzerland - United Kingdom - United States of America

www.st.com