

LNB supply and control IC with step-up and I²C interface

Features

- Complete interface between LNB and I²C bus
- Built-in DC-DC converter for single 12 V supply operation and high efficiency (typ. 93% @ 0.5 A)
- Selectable output current limit by external resistor
- Compliant with main satellite receivers output voltage specification
- Auxiliary modulation input (EXTM pin) facilitates DiSEqC™ 1.X encoding
- Accurate built-in 22 kHz tone generator suits widely accepted standards
- Low-drop post regulator and high efficiency step-up PWM with integrated power NMOS allow low power losses
- Overload and over-temperature internal protections with I²C diagnostic bits
- LNB short circuit dynamic protection
- ± 4 kV ESD tolerant on output power pins

Applications

- STB satellite receivers
- TV satellite receivers
- PC card satellite receivers

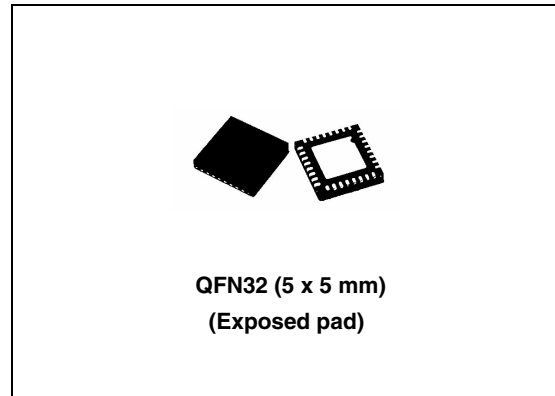

Description

Intended for analog and digital satellite receivers, the LNBH23L is a monolithic voltage regulator and interface IC, assembled in QFN32 5 x 5 specifically designed to provide the 13 / 18 V power supply and the 22 kHz tone signalling to the LNB down-converter in the antenna dish or to the multi-switch box. In this application field, it offers a complete solution with extremely low component count, low power dissipation together with simple design and I²C standard interfacing.

Table 1. Device summary

Order code	Package	Packaging
LNBH23LQTR	QFN32 (5 x 5 mm) Exposed pad	Tape and reel

Contents

1	Block diagram	4
2	Application information	5
2.1	DiSEqC™ data encoding	5
2.2	DiSEqC™ 1.X implementation by EXTM pin	5
2.3	DiSEqC™ 1.X implementation with VOTX and EXTM pin connection	5
2.4	PDC optional circuit for DiSEqC™ 1.X applications using VOTX signal on to EXTM pin	6
2.5	I ² C interface	6
2.6	Output voltage selection	6
2.7	Diagnostic and protection functions	6
2.8	Over-current and short circuit protection and diagnostic	6
2.9	Thermal protection and diagnostic	7
2.10	Output current limit selection	7
3	Pin configuration	8
4	Maximum ratings	10
5	Typical application circuit	11
6	I²C bus interface	14
6.1	Data validity	14
6.2	Start and stop condition	14
6.3	Byte format	14
6.4	Acknowledge	14
6.5	Transmission without acknowledge	14
7	LNBH23L software description	16
7.1	Interface protocol	16
7.2	System register (SR, 1 byte)	16
7.3	Transmitted data (I ² C bus write mode)	16
7.4	Diagnostic received data (I ² C read mode)	17

7.5	Power-on I ² C interface reset	18
7.6	Address pin	18
7.7	DiSEqC™ implementation	18
8	Electrical characteristics	19
9	Package mechanical data	21
10	Revision history	24

1 Block diagram

Figure 1. Block diagram

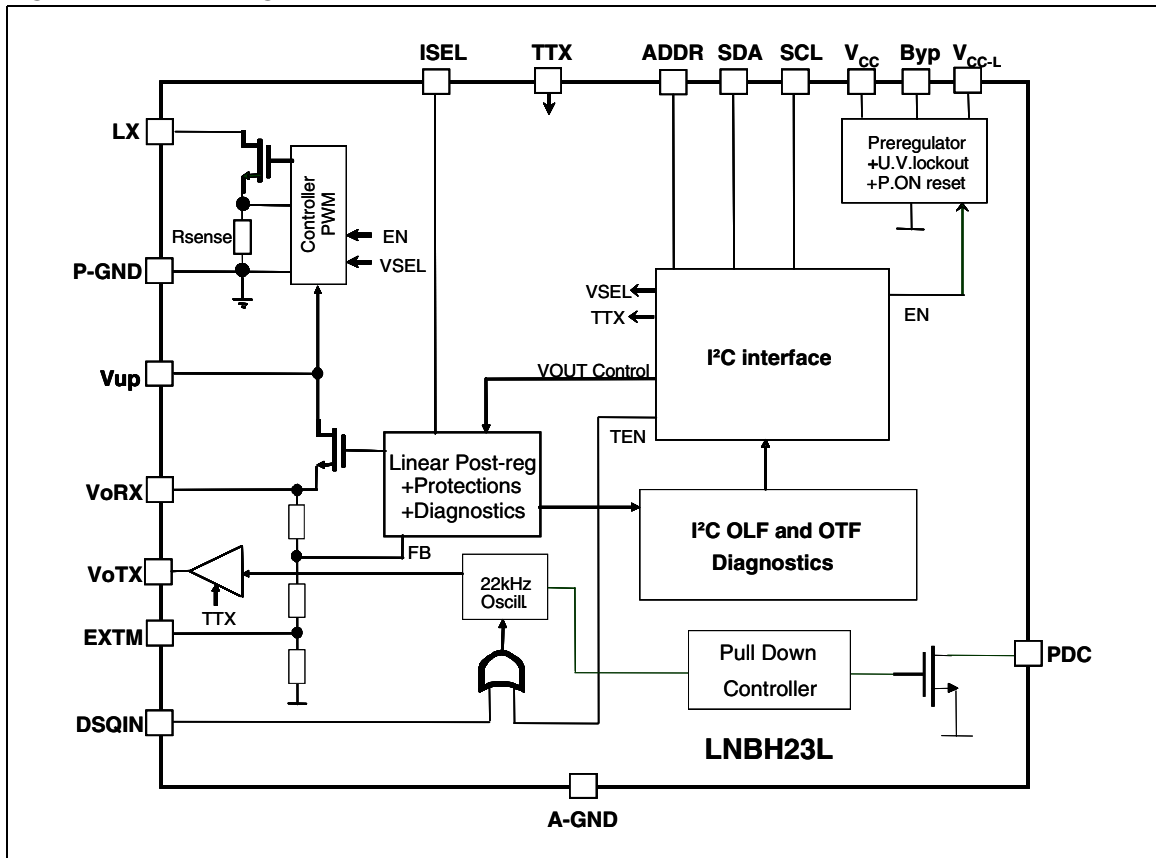

2 Application information

This IC has a built-in DC-DC step-up converter that, from a single source from 8 V to 15 V, generates the voltages (V_{UP}) that let the linear post-regulator to work at a minimum dissipated power of 0.55 W typ. @ 500 mA load (the linear post-regulator drop voltage is internally kept at $V_{UP} - V_{OUT} = 1.1$ V typ.). An under voltage lockout circuit will disable the whole circuit when the supplied V_{CC} drops below a fixed threshold (6.7 V typically).

Note: In this document the V_{OUT} is intended as the voltage present at the linear post-regulator output (V_{ORX} pin).

2.1 DiSEqC™ data encoding

The internal 22 kHz tone generator is factory trimmed in accordance to the standards, and can be selected by I²C interface TTX bit (or TTX pin) and activated by a dedicated pin (DSQIN) that allows immediate DiSEqC™ data encoding, or through TEN I²C bit in case the 22 kHz presence is requested in continuous mode. In stand-by condition (EN bit LOW) The TTX function must be disabled setting TTX to LOW. Besides the internal 22 kHz tone generator, the auxiliary modulation pin (EXTM) can be driven by an external 22 kHz source and in this case TTX must be set to low.

2.2 DiSEqC™ 1.X implementation by EXTM pin

In order to improve design flexibility and reduce the total application cost, an analogic modulation input pin is available (EXTM) to generate the 22 kHz tone superimposed to the V_{ORX} DC output voltage. An appropriate DC blocking capacitor must be used to couple the modulating signal source to the EXTM pin. If the EXTM solution is used the output R-L filter can be removed (see [Figure 5](#)) saving the external components cost. If this configuration is used keep TTX set to low.

The pin EXTM modulates the V_{ORX} voltage through the series decoupling capacitor, so that:

$$V_{ORX(AC)} = V_{EXTM(AC)} \times G_{EXTM}$$

Where $V_{ORX(AC)}$ and $V_{EXTM(AC)}$ are, respectively, the peak to peak voltage on the V_{ORX} and EXTM pins while G_{EXTM} is the voltage gain from EXTM to V_{ORX} .

2.3 DiSEqC™ 1.X implementation with V_{OTX} and EXTM pin connection

If an external 22 kHz tone source is not available, it is possible to use the internal 22 kHz tone generator signal available through the V_{OTX} pin to drive the EXTM pin. The V_{OTX} pin internal circuit must be preventively set ON by setting the TTX function to High. This can be controlled both through the TTX pin or by I²C bit. By this way the V_{OTX} 22 kHz signal will be superimposed to the V_{ORX} DC voltage to generate the LNB output 22 kHz tone (see [Figure 3](#)). After TTX is set to High the internal 22 kHz tone generator available through the V_{OTX} pin can be activated during the 22 kHz transmission either by DSQIN pin or by the TEN bit. The DSQIN internal circuit activates the 22 kHz tone on the V_{OTX} output with 0.5 cycles \pm 25 μ s delay from the TTL signal presence on the DSQIN pin, and it stops with 1 cycles \pm 25 μ s delay after the TTL signal is expired. As soon as the tone transmission is expired, the

V_{OTX} internal circuits must be disabled by setting the TTX to LOW. The 13 / 18 V power supply will be always provided to the LNB from the V_{ORX} pin.

2.4 PDC optional circuit for DiSEQC™ 1.X applications using V_{OTX} signal on to EXTM pin

In some applications, at light output current (< 50 mA) having heavy LNB output capacitive load, the 22 kHz tone can be distorted. In this case it is possible to add the "Optional" external components shown in the typical application circuits (see [Figure 4](#)) connected between V_{ORX} and PDC pin. This optional circuit acts as an active pull-down discharging the output capacitance only when the internal 22 kHz tone is activated. This optional circuit is not needed in standard applications having $I_{OUT} > 50$ mA and capacitive load up to 250 nF.

2.5 I²C interface

The main functions of the IC are controlled via I²C bus by writing 6 bits on the system register (SR 8 bits in write mode). On the same register there are 5 bits that can be read back (SR 8 bits in read mode) to provide the diagnostic flags of two internal monitoring functions (OTF, OLF) and three output voltage register status (EN, VSEL, LLC) received by the IC (see below diagnostic functions section). In read mode there are 3 Test bits (test 1 - 2 - 3) that must be disregarded from the MCU. While, in write mode, 2 test bits (test 4 - 5) must be always set LOW.

2.6 Output voltage selection

When the IC sections are in stand-by mode (EN bit LOW), the power blocks are disabled. When the regulator blocks are active (EN bit HIGH), the output can be logic controlled to be 13 or 18 V by means of the V_{SEL} bit (voltage SElect). Additionally, the LNBH23L is provided with the LLC I²C bit that increases the selected voltage value to compensate possible voltage drop along the output line. The LNBH23L is also compliant to the USA LNB power supply standards. In stand-by condition (EN bit LOW) all the I²C bits and the TTX pin must be set LOW (if the TTX pin is not used it can be left floating or to GND but the TTX bit must be set LOW during the stand-by condition).

2.7 Diagnostic and protection functions

The LNBH23L has two diagnostic internal functions provided via I²C bus by reading 2 bits on the system register (SR bits in read mode). the diagnostic bits are, in normal operation (no failure detected), set to LOW. The diagnostic bits are dedicated to the over-temperature and over-load protections status (OTF and OLF).

2.8 Over-current and short circuit protection and diagnostic

In order to reduce the total power dissipation during an overload or a short circuit condition, the device is provided with a dynamic short circuit protection. It is possible to set the short circuit current protection either statically (simple current clamp) or dynamically by the PCL bit of the I²C SR. When the PCL (pulsed current limiting) bit is set to LOW, the over current protection circuit works dynamically: as soon as an overload is detected, the output is shut-

down for a time T_{OFF} typically 900 ms. Simultaneously the diagnostic OLF I²C bit of the system register is set to "1". After this time has elapsed, the output is resumed for a time $T_{ON} = 1/10 T_{OFF} = 90$ ms (typ.). At the end of T_{ON} , if the overload is still detected, the protection circuit will cycle again through T_{OFF} and T_{ON} . At the end of a full T_{ON} in which no overload is detected, normal operation is resumed and the OLF diagnostic bit is reset to LOW. Typical $T_{ON} + T_{OFF}$ time is 990ms and an internal timer determines it. This dynamic operation can greatly reduce the power dissipation in short circuit condition, still ensuring excellent power-on start-up in most conditions. However, there could be some cases in which a highly capacitive load on the output may cause a difficult start-up when the dynamic protection is chosen. This can be solved by initiating any power start-up in static mode ($PCL = 1$) and, then, switching to the dynamic mode ($PCL = 0$) after a chosen amount of time depending on the output capacitance. When in static mode, the diagnostic OLF bit goes to "1" when the current clamp limit is reached and returns LOW when the overload condition is cleared.

2.9 Thermal protection and diagnostic

The LNBH23L is also protected against overheating: when the junction temperature exceeds 150 °C (typ.), the step-up converter and the liner regulator are shut-off, and the diagnostic OTF SR bit is set to "1". Normal operation is resumed and the OTF bit is reset to LOW when the junction is cooled down to 135 °C (typ.)

2.10 Output current limit selection

The linear regulator current limit threshold can be set by an external resistor connected to ISEL pin. The resistor value defines the output current limit by the equation:

$$I_{MAX} (A) = 10000 / R_{SEL}$$

where R_{SEL} is the resistor connected between I_{SEL} and GND. The highest selectable current limit threshold shall be 0.65 A typ with $R_{SEL} = 15$ k Ω . The above equation defines the typical threshold value.

Note: External components are needed to comply DiSEqC™ bus hardware requirements. Full compliance of the whole application with DiSEqC™ specifications is not implied by the bare use of this IC. NOTICE: DiSEqC™ is a trademark of EUTELSAT.

3 Pin configuration

Figure 2. Pin connections (bottom view)

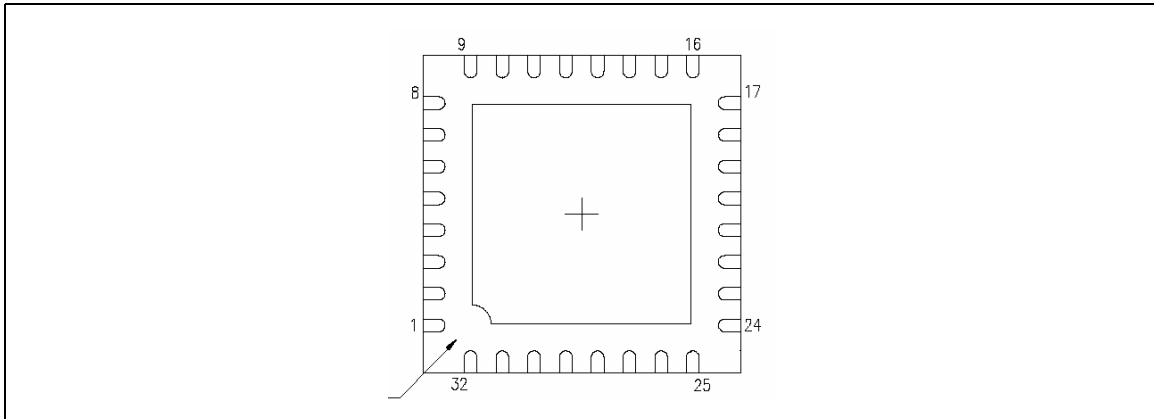

Table 2. Pin description

Pin n°	Symbol	Name	Pin function
19	V _{CC}	Supply input	8 to 15 V IC DC-DC power supply.
18	V _{CC-L}	Supply input	8 to 15 V analog power supply.
4	LX	NMOS drain	Integrated N-channel power MOSFET drain.
27	V _{UP}	Step-up voltage	Input of the linear post-regulator. The voltage on this pin is monitored by the internal step-up controller to keep a minimum dropout across the linear pass transistor.
21	V _{ORX}	LDO output port	Output of the integrated low drop linear regulator. See truth tables for voltage selections and description.
22	V _{OTX}	Output port for 22 kHz Tone TX	TX Output to the LNB. See truth tables for selection.
6	SDA	Serial data	Bi-directional data from/to I ² C bus.
9	SCL	Serial clock	Clock from I ² C bus.
12	DSQIN	DiSEqC input	This pin will accept the DiSEqC code from the main μ Controller. The LNBH23L will use this code to modulate the internally generated 22 kHz carrier. Set to ground if not used.
14	TTX	TTX enable	This pin can be used, as well as the TTX I ² C bit of the system register, to control the TTX function enable before to start the 22 kHz tone transmission. Set floating or to GND if not used.
29	Reserved	Reserved	To be connected to GND.
11	PDC	Pull down control	To be connected to the external NPN transistor Base to reduce the 22 kHz tone distortion in case of heavy capacitive load at light output current. If not used it can be left floating.
13	EXTM	External modulation	External Modulation Input acts on V _{ORX} linear regulator output to superimpose an external 22 kHz signal. Needs DC decoupling to the AC source. If not used it can be left floating.
5	P-GND	Power ground	DC-DC converter power ground.

Table 2. Pin description (continued)

Pin n°	Symbol	Name	Pin function
Epad	Epad	Exposed pad	To be connected with power grounds and to the ground layer through vias to dissipate the heat.
20	A-GND	Analog ground	Analog circuits ground.
15	BYP	By-pass capacitor	Needed for internal pre-regulator filtering. The BYP pin is intended only to connect an external ceramic capacitor. Any connection of this pin to external current or voltage sources may cause permanent damage to the device.
10	ADDR	Address setting	Two I ² C bus addresses available by setting the Address pin level voltage. See address pin characteristics table.
28	ISEL	Current selection	The resistor "RSEL" connected between ISEL and GND defines the linear regulator current limit threshold by the equation: $I_{MAX}(typ.) = 10000 / RSEL$.
30	Reserved	Reserved	To be left floating. Do not connect to GND.
1, 2, 3, 7, 8, 16, 17, 23, 24, 25, 26, 31, 32	N.C.	Not internally connected	Not internally connected pins. These pins can be connected to GND to improve thermal performances.

4 Maximum ratings

Table 3. Absolute maximum ratings ⁽¹⁾

Symbol	Parameter	Value	Unit
V_{CC-L}, V_{CC}	DC power supply input voltage pins	-0.3 to 16	V
V_{UP}	DC input voltage	-0.3 to 24	V
I_{OUT}	Output current	Internally limited	mA
V_{ORX}	DC output pin voltage	-0.3 to 25	V
V_{OTX}	Tone output pin voltage	-0.3 to 25	V
V_I	Logic input voltage (TTX, SDA, SCL, DSQIN, ADDR pins)	-0.3 to 7	V
V_{OH}	Logic high output voltage (PDC pin)	-0.3 to 7	V
V_{EXTM}	EXTM pin voltage	-0.3 to 2	V
LX	LX input voltage	-0.3 to 24	V
V_{BYP}	Internal reference pin voltage ⁽²⁾	-0.3 to 4.6	V
ISEL	Current selection pin voltage	-0.3 to 4.6	V
T_{STG}	Storage temperature range	-50 to 150	°C
T_J	Operating junction temperature range	-25 to 125	°C
ESD	ESD rating with human body model (HBM) for all pins unless 4, 21, 22	2	kV
	ESD rating with human body model (HBM) for pins 21, 22	4	
	ESD rating with human body model (HBM) for pin 4	0.6	

1. Absolute maximum ratings are those values beyond which damage to the device may occur. These are stress ratings only and functional operation of the device at these conditions is not implied. Exposure to absolute-maximum-rated conditions for extended periods may affect device reliability. All voltage values are with respect to network ground terminal.

2. The BYP pin is intended only to connect an external ceramic capacitor. Any connection of this pin to external current or voltage sources may cause permanent damage to the device.

Table 4. Thermal data

Symbol	Parameter	Value	Unit
R_{thJC}	Thermal resistance junction-case	2	°C/W
R_{thJA}	Thermal resistance junction-ambient with device soldered on 2s2p PC board	35	°C/W

5 Typical application circuit

Figure 3. DiSEqC 1.x using internal 22 kHz tone generator

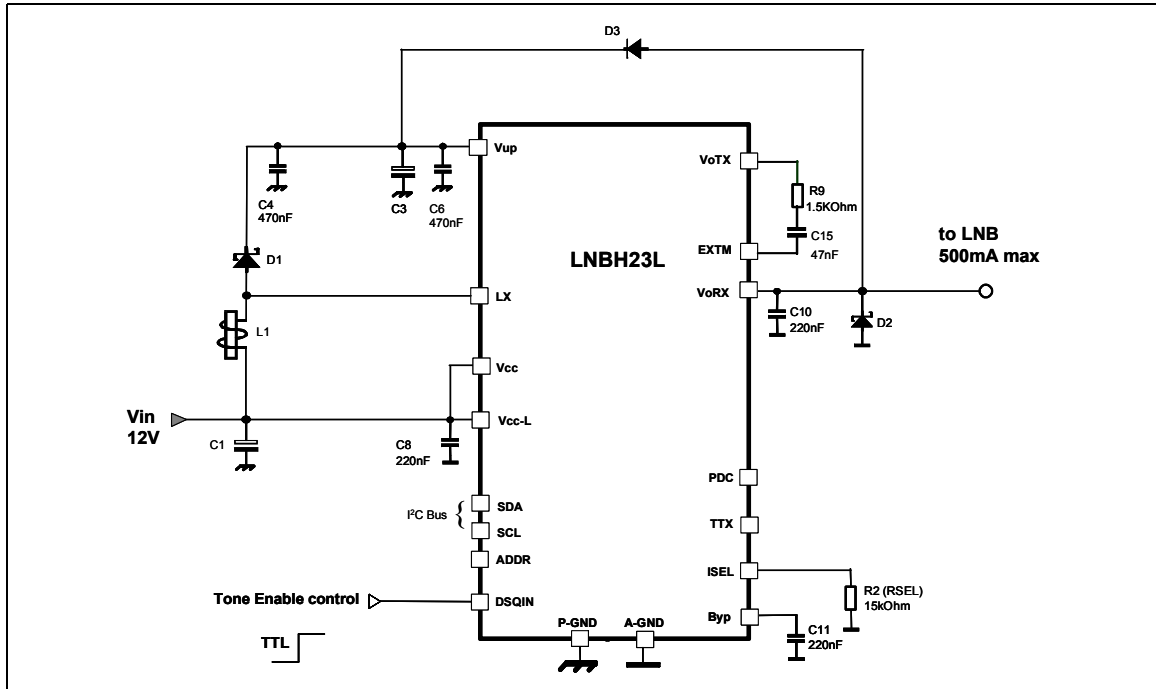

Figure 4. DiSEqC 1.x using internal 22 kHz tone generator and "optional" PDC circuit

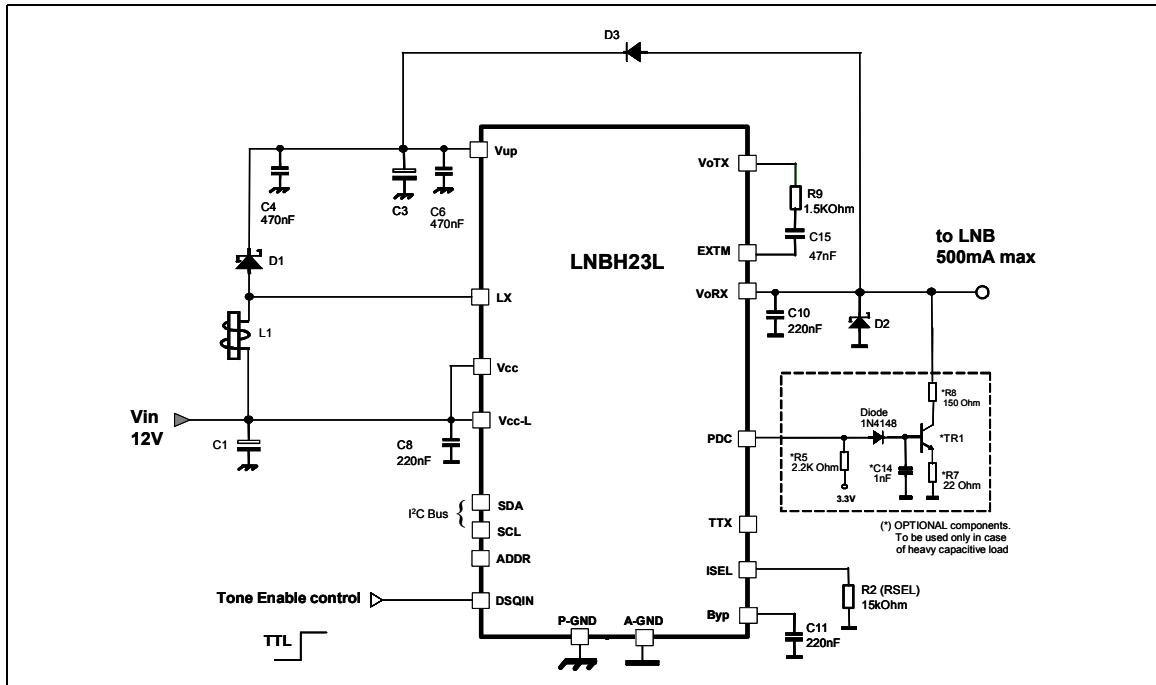

Figure 5. DiSEqC 1.x using external 22 kHz tone generator source through EXTM pin

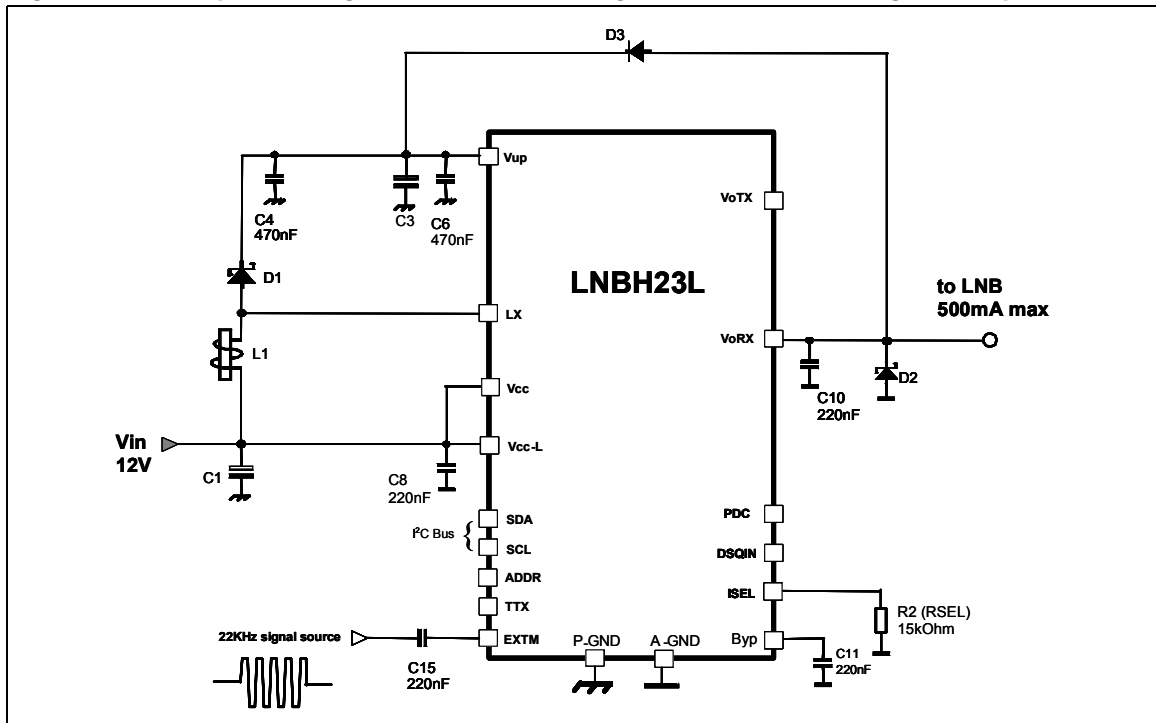

Table 5. BOM list

Component	Notes
R2, R9, R5 ⁽¹⁾	1/16 W resistors. Refer to the typical application circuit for the relative values
R7 ⁽¹⁾ , R8 ⁽¹⁾	1/2 W resistors. Refer to the typical application circuit for the relative values
C1	25 V electrolytic capacitor, 100 µF or higher is suitable
C3	25 V, 220 µF electrolytic capacitor, ESR in the 100 mΩ to 350 mΩ range
C4, C6, C8, C10, C11, C15, C14 ⁽¹⁾	25 V ceramic capacitors. Refer to the typ. appl. circuit for the relative values
D1	STPS130A or any similar schottky diode with $V_{RRM} > 25\text{ V}$ and $I_{F(AV)}$ higher than: $I_{F(AV)} > I_{OUT_MAX} \times (V_{UP_MAX}/V_{IN_MIN})$
D2	BAT43, 1N5818, or any schottky diode with $I_{F(AV)} > 0.2\text{ A}$, $V_{RRM} > 25\text{ V}$, $V_F < 0.5\text{ V}$. To be placed as close as possible to V_{ORX} pin
D3	1N4001-07 or any similar general purpose rectifier
TR1 ⁽¹⁾	BC817 or similar NPN general-purpose transistor.
L1	22 µH inductor with $I_{SAT} > I_{PEAK}$ where I_{PEAK} is the boost converter peak current (see Equation 1)

1. These components can be added to avoid any 22 kHz tone distortion due to heavy capacitive output loads. If not needed they can be removed leaving the PDC pin floating.

To calculate the boost converter peak current (I_{PEAK}) of L1, use the following formula:

Equation 1

$$I_{PEAK} = \frac{V_{UP_MAX} * I_{OUT_MAX}}{Eff * V_{IN_MIN}} + \frac{V_{IN_MIN}}{2LF} \left(1 - \frac{V_{IN_MIN}}{V_{UP_MAX}} \right)$$

6 I²C bus interface

Data transmission from main microprocessor to the LNBH23L and vice versa takes place through the 2 wires I²C bus Interface, consisting of the 2 lines SDA and SCL (pull-up resistors to positive supply voltage must be externally connected).

6.1 Data validity

As shown in [Figure 6](#), the data on the SDA line must be stable during the high semi-period of the clock. The HIGH and LOW state of the data line can only change when the clock signal on the SCL line is LOW.

6.2 Start and stop condition

As shown in [Figure 7](#) a start condition is a HIGH to LOW transition of the SDA line while SCL is HIGH. The stop condition is a LOW to HIGH transition of the SDA line while SCL is HIGH. A STOP condition must be sent before each START condition.

6.3 Byte format

Every byte transferred to the SDA line must contain 8 bits. Each byte must be followed by an acknowledge bit. The MSB is transferred first.

6.4 Acknowledge

The master (microprocessor) puts a resistive HIGH level on the SDA line during the acknowledge clock pulse (see [Figure 8](#)). The peripheral (LNBH23L) that acknowledges has to pull-down (LOW) the SDA line during the acknowledge clock pulse, so that the SDA line is stable LOW during this clock pulse. The peripheral which has been addressed has to generate acknowledge after the reception of each byte, otherwise the SDA line remains at the HIGH level during the ninth clock pulse time. In this case the master transmitter can generate the STOP information in order to abort the transfer. The LNBH23L won't generate acknowledge if the V_{CC} supply is below the under voltage lockout threshold (6.7 V typ.).

6.5 Transmission without acknowledge

Avoiding to detect the acknowledges of the LNBH23L, the microprocessor can use a simpler transmission: simply it waits one clock cycle without checking the slave acknowledging, and sends the new data. This approach of course is less protected from misworking and decreases the noise immunity.

Figure 6. Data validity on the I²C bus

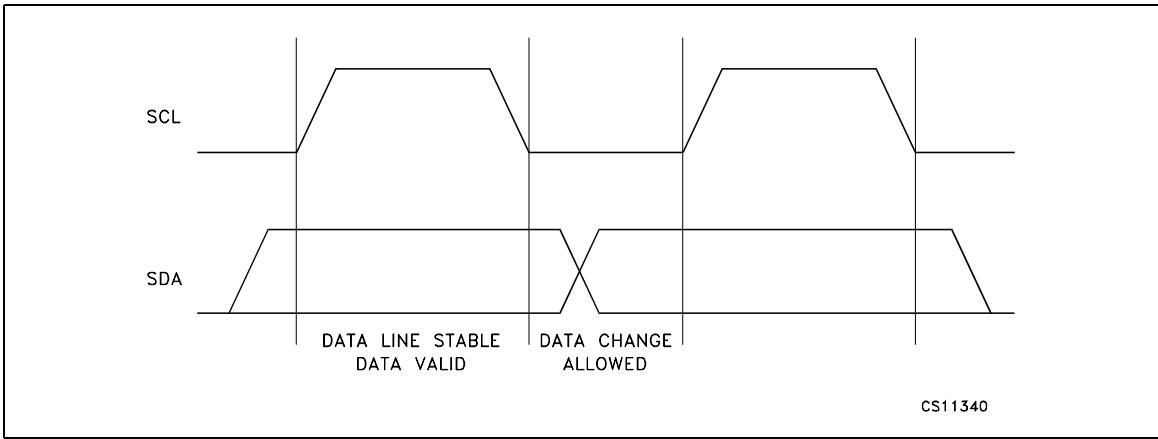

Figure 7. Timing diagram of I²C bus

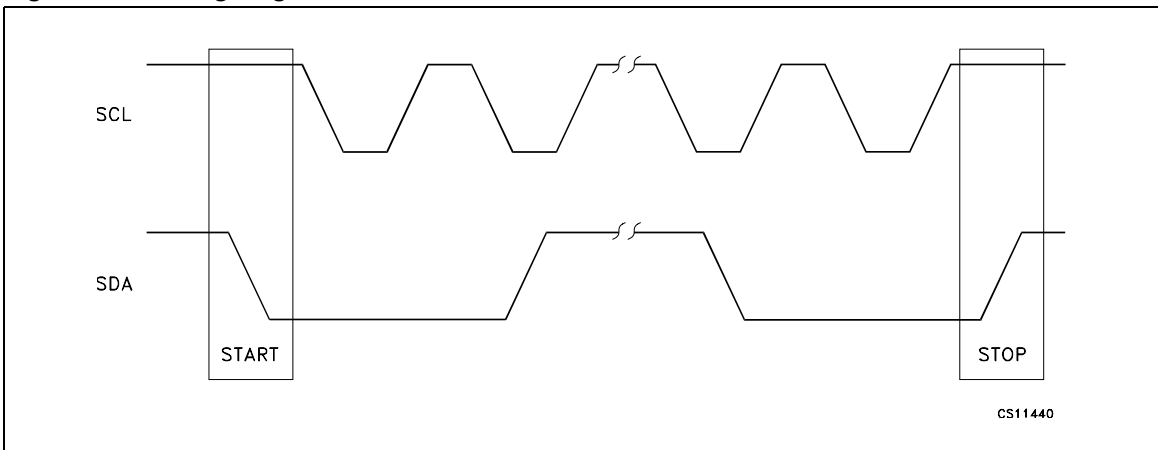
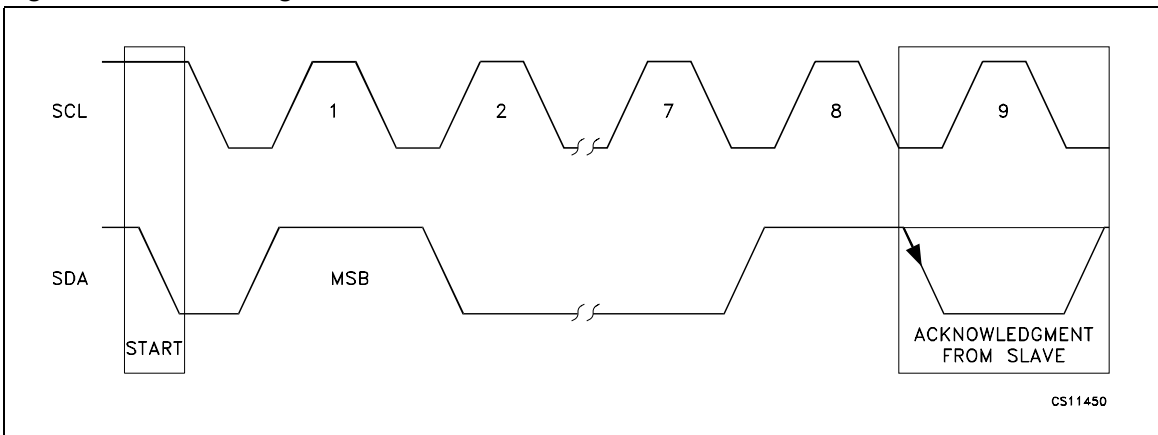

Figure 8. Acknowledge on the I²C bus



7 LNBH23L software description

7.1 Interface protocol

The interface protocol comprises:

- A start condition (S)
- A chip address byte (the LSB bit determines read (=1)/write (=0) transmission)
- A sequence of data (1 byte + acknowledge)
- A stop condition (P)

Section address (A or B)										Data									
MSB										LSB									
S	0	0	0	1	0	1	X	R/W	ACK									ACK	P

ACK = Acknowledge

S = Start

P = Stop

R/W = 1/0, Read/Write bit

X = 0/1, two addresses selectable by ADDR pin (see [Table 10](#))

7.2 System register (SR, 1 byte)

Mode	MSB							LSB	
Write	PCL	TTX	TEN	LLC	VSEL	EN	TEST4	TEST5	
Read	TEST1	TEST2	TEST3	LLC	VSEL	EN	OTF	OLF	

Write = control bits functions in write mode

Read= diagnostic bits in read mode.

All bits reset to 0 at Power-on

7.3 Transmitted data (I²C bus write mode)

When the R/W bit in the chip address is set to 0, the main microprocessor can write on the system register (SR) of the LNBH23L via I²C bus. 6 bits are available and can be written by the microprocessor to control the device functions as per the below truth table [Table 6](#).

Table 6. Truth table

PCL	TTX	TEN	LLC	VSEL	EN	TEST4	TEST5	Function
	0		0	0	1	0	0	$V_{oRX} = 13.4 \text{ V}$, $V_{UP} = 14.5 \text{ V}$, ($V_{UP} - V_{oRX} = 1.1 \text{ V}$)
	0		0	1	1	0	0	$V_{oRX} = 18.4 \text{ V}$, $V_{UP} = 19.5 \text{ V}$, ($V_{UP} - V_{oRX} = 1.1 \text{ V}$)
	0		1	0	1	0	0	$V_{oRX} = 14.4 \text{ V}$, $V_{UP} = 15.5 \text{ V}$, ($V_{UP} - V_{oRX} = 1.1 \text{ V}$)
	0		1	1	1	0	0	$V_{oRX} = 19.5 \text{ V}$, $V_{UP} = 20.6 \text{ V}$, ($V_{UP} - V_{oRX} = 1.1 \text{ V}$)
	0	0			1	0	0	Internal 22 kHz generator disabled, EXTM modulation enabled
	1	0			1	0	0	Internal 22 kHz controlled by DSQIN pin (only if TTX=1)
	1	1			1	0	0	Internal 22 kHz tone output is always activated
	0				1	0	0	V_{oRX} output is ON, V_{oTX} Tone generator output is OFF
	1				1	0	0	V_{oRX} output is ON, V_{oTX} Tone generator output is ON
0	X				1	0	0	Pulsed (Dynamic) current limiting is selected
1	X				1	0	0	Static current limiting is selected
X	X	X	X	X	0	0	0	Power block disabled

X = don't care

All values are typical unless otherwise specified

Valid with TTX pin floating

7.4 Diagnostic received data (I²C read mode)

LNBH23L can provide to the MCU master a copy of the diagnostic system register information via I²C bus in read mode. The read mode is master activated by sending the chip address with R/W bit set to 1. At the following master generated clocks bits, LNBH23L issues a byte on the SDA data bus line (MSB transmitted first). At the ninth clock bit the Master can:

- Acknowledge the reception, starting in this way the transmission of another byte from the LNBH23L
- No acknowledge, stopping the read mode communication

Three bits of the register are read back as a copy of the corresponding write output voltage register status (LLC, VSEL, EN), two bits convey diagnostic information about the over-temperature (OTF), output over-load (OLF) and three bit are for internal usage (TEST1-2-3) and must be disregarded by the MCU software. In normal operation the diagnostic bits are set to zero, while, if a failure is occurring, the corresponding bit is set to one. At start-up all the bits are reset to zero.

Table 7. Register

TEST1	TEST2	TEST3	LLC	VSEL	EN	OTF	OLF	Function
			These bits are read exactly the same as they were left after last write operation			0		$T_J < 135^\circ\text{C}$, normal operation
						1		$T_J > 150^\circ\text{C}$, power blocks disabled
							0	$I_O < I_{O\text{MAX}}$, normal operation
							1	$I_O > I_{O\text{MAX}}$, Overload protection triggered
X	X	X						These bits status must be disregarded by the MCU.

Values are typical unless otherwise specified.

x = don't care.

7.5 Power-on I²C interface reset

I²C interface built in LNBH23L is automatically reset at power-on. As long as the V_{CC} stays below the under voltage lockout (UVL) threshold (6.7 V), the interface does not respond to any I²C command and the system register (SR) is initialized to all zeroes, thus keeping the power blocks disabled. Once the V_{CC} rises above 7.3 V typ. The I²C interface becomes operative and the SR can be configured by the main microprocessor. This is due to 500 mV of hysteresis provided in the UVL threshold to avoid false retriggering of the power-on reset circuit.

7.6 Address pin

It is possible to select two I²C interface addresses by means of ADDR pin. This pin is TTL compatible and can be set as per address pin characteristics [Table 10](#).

7.7 DiSEqC™ implementation

LNBH23L helps system designer to implement DiSEqC 1.x protocol by allowing an easy PWK modulation of the 22 kHz carrier through the EXT_M and $V_{o\text{TX}}$ pins. Full compliance of the system to the specification is thus not implied by the bare use of the LNBH23L (see [Figure 3](#), [Figure 4](#) and [Figure 5](#)).

8 Electrical characteristics

Refer to the typical application circuits, T_J from 0 to 85 °C, EN=1, VSEL=LLC=TEN=PCL=TEST4=TEST5=TTX=0, $R_{SEL}=15\text{ k}\Omega$, DSQIN=LOW, $V_{IN}=12\text{ V}$, $I_{OUT}=50\text{ mA}$, unless otherwise stated. Typical values are referred to $T_J=25\text{ }^\circ\text{C}$. $V_{OUT}=V_{ORX}$ pin voltage. See software description section for I²C access to the system register.

Table 8. Electrical characteristics

Symbol	Parameter	Test conditions	Min.	Typ.	Max.	Unit	
V_{IN}	Supply voltage	$I_{OUT}=500\text{mA}$, VSEL=LLC=1	8	12	15	V	
I_{IN}	Supply current	$I_{OUT}=0$		7	15	mA	
		EN=TEN=TTX=1, $I_{OUT}=0$, PDC circuit not connected		20	40		
		EN=0		2			
V_{OUT}	Output voltage	VSEL=1 $I_{OUT}=500\text{mA}$	LLC=0	17.8	18.4	19.2	V
			LLC=1		19.5		
V_{OUT}	Output voltage	VSEL=0 $I_{OUT}=500\text{mA}$	LLC=0	12.8	13.4	14	V
			LLC=1		14.4		
V_{OUT}	Line regulation	$V_{IN}=8\text{ to }15\text{V}$	VSEL=0		5	40	mV
			VSEL=1		5	60	
V_{OUT}	Load regulation	VSEL=0 or 1 I_{OUT} from 50 to 500mA			200		
I_{MAX}	Output current limiting thresholds	$R_{SEL}=15\text{ k}\Omega$		500		800	mA
		$R_{SEL}=22\text{ k}\Omega$		300		600	
I_{SC}	Output short circuit current	VSEL=0/1, AUX=0/1		1000		mA	
T_{OFF}	Dynamic overload protection OFF time	PCL=0, output shorted		900		ms	
T_{ON}	Dynamic overload protection ON time	PCL=0, output shorted		$T_{OFF}/10$			
F_{TONE}	Tone frequency	DSQIN=HIGH or TEN=1, TTX=1 (Using internal tone generator)	18	22	26	kHz	
A_{TONE}	Tone amplitude	DSQIN=HIGH or TEN=1, TTX=1, DiSEqC 1.X configuration using internal generator, I_{OUT} from 0 to 500mA, C_{OUT} from 0 to 750nF, PDC Optional circuit connected to V_{ORX} fail	0.4	0.650	0.9	V_{PP}	
D_{TONE}	Tone duty cycle	DSQIN=HIGH or TEN=1, TTX=1 (Using internal tone generator)	40	50	60	%	
t_r, t_f	Tone rise or fall time	DSQIN=HIGH or TEN=1, TTX=1 (Using internal tone generator)	5	8	15	μs	
V_{PDC_OL}	PDC pin logic LOW	$I_{PDC}=2\text{mA}$		0.3		V	
I_{PDC_OZ}	PDC pin leakage current	$V_{PDC}=5\text{V}$		1		μA	
G_{EXTM}	External modulation gain	$\Delta V_{OUT}/\Delta V_{EXTM}$, freq. from 10 kHz to 50 kHz		1.8			

Table 8. Electrical characteristics (continued)

Symbol	Parameter	Test conditions	Min.	Typ.	Max.	Unit
V_{EXTM}	External modulation input voltage	EXTM AC coupling ⁽¹⁾			400	mV _{PP}
Z_{EXTM}	External modulation impedance			2.0		k Ω
Eff _{DC-DC}	DC-DC converter efficiency	I _{OUT} =500mA		93		%
F_{SW}	DC-DC converter switching frequency			220		kHz
V_{IL}	DSQIN, TTX, pin logic low				0.8	V
V_{IH}	DSQIN, TTX, pin logic high		2			V
I_{IH}	DSQIN, TTX, pin input current	$V_{IH}=5V$		15		μA
I_{OBK}	Output backward current	EN=0, $V_{OBK}=21V$		-6	-15	mA
T_{SHDN}	Thermal shut-down threshold			150		$^{\circ}C$
ΔT_{SHDN}	Thermal shut-down hysteresis			15		$^{\circ}C$

1. External signal maximum voltage for which the EXTM function is guaranteed.

Table 9. I²C electrical characteristics ⁽¹⁾

Symbol	Parameter	Test conditions	Min.	Typ.	Max.	Unit
V_{IL}	LOW level input voltage	SDA, SCL			0.8	V
V_{IH}	HIGH level input voltage	SDA, SCL	2			V
I_I	Input current	SDA, SCL, $V_I = 0.4$ to $4.5V$	-10		10	μA
V_{OL}	Low level output voltage	SDA (open drain), I _{OL} = 6mA			0.6	V
f_{MAX}	Maximum clock frequency	SCL	400			kHz

1. T_J from 0 to 85 $^{\circ}C$, $V_I = 12 V$.

Table 10. Address pins characteristics ⁽¹⁾

Symbol	Parameter	Test condition	Min.	Typ.	Max.	Unit
V_{ADDR-1}	"0001010(R/W)" Address pin voltage range	R/W bit determines the transmission mode: read (R/W=1) write (R/W=0)	0		0.8	V
V_{ADDR-2}	"0001011(RW)" Address pin voltage range	R/W bit determines the transmission mode: read (R/W=1) write (R/W=0)	2		5	V
$V_{ADDR-3}^{(2)}$	"0001000(RW)" Address pin voltage range	R/W bit determines the transmission mode: read (R/W=1) write (R/W=0)	0		5	V

1. T_J from 0 to 85 $^{\circ}C$, $V_I = 12 V$

2. This I²C address is reserved only for internal usage. Do not use this address with other I²C peripherals to avoid address conflicts.

9 Package mechanical data

In order to meet environmental requirements, ST offers these devices in different grades of ECOPACK[®] packages, depending on their level of environmental compliance. ECOPACK[®] specifications, grade definitions and product status are available at: www.st.com. ECOPACK[®] is an ST trademark.

Table 11. QFN32 (5 x 5 mm) mechanical data

Dim.	(mm.)		
	Min.	Typ.	Max.
A	0.80	0.90	1.00
A1	0	0.02	0.05
A3		0.20	
b	0.18	0.25	0.30
D	4.85	5.00	5.15
D2	3.20		3.70
E	4.85	5.00	5.15
E2	3.20		3.70
e		0.50	
L	0.30	0.40	0.50
ddd			0.08

Figure 9. QFN32 package dimensions

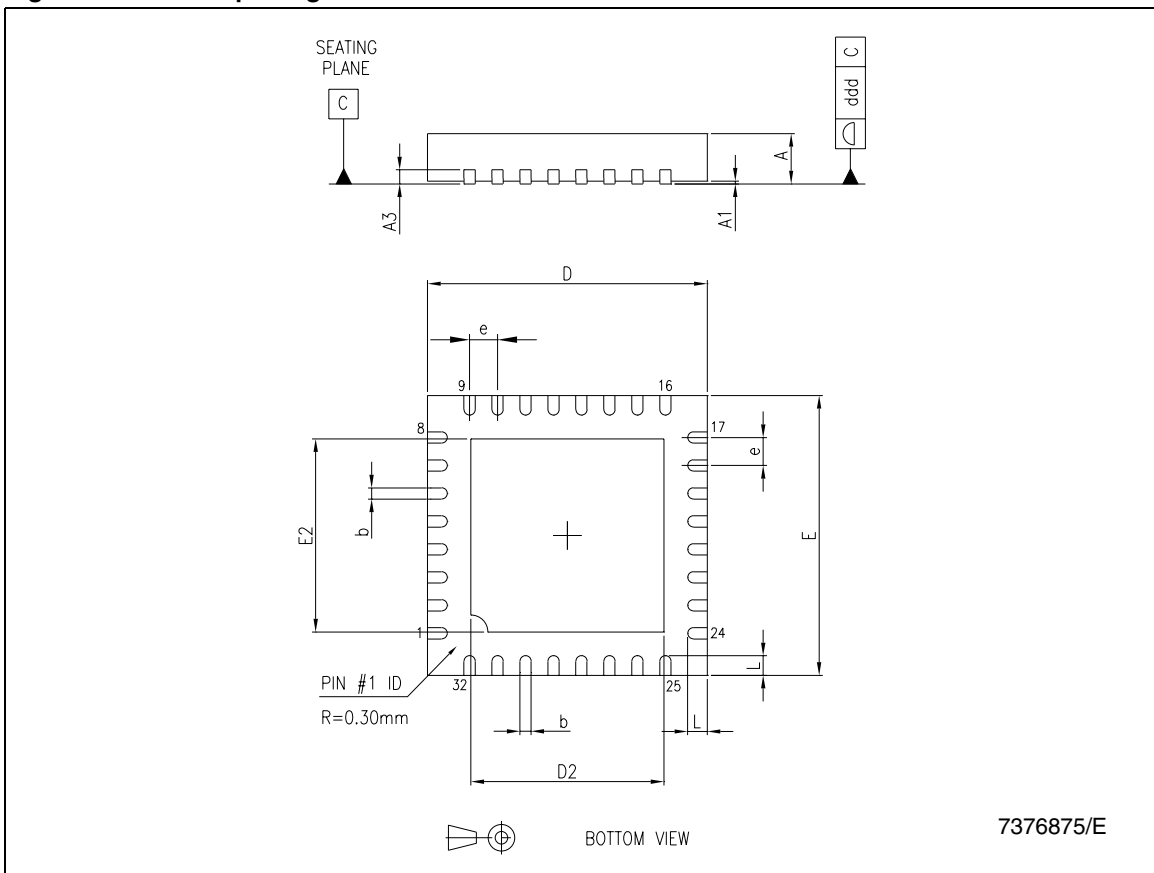

Tape & reel QFNxx/DFNxx (5x5 mm.) mechanical data

Dim.	mm.			inch.		
	Min.	Typ.	Max.	Min.	Typ.	Max.
A			330			12.992
C	12.8		13.2	0.504		0.519
D	20.2			0.795		
N	99		101	3.898		3.976
T			14.4			0.567
Ao		5.25			0.207	
Bo		5.25			0.207	
Ko		1.1			0.043	
Po		4			0.157	
P		8			0.315	

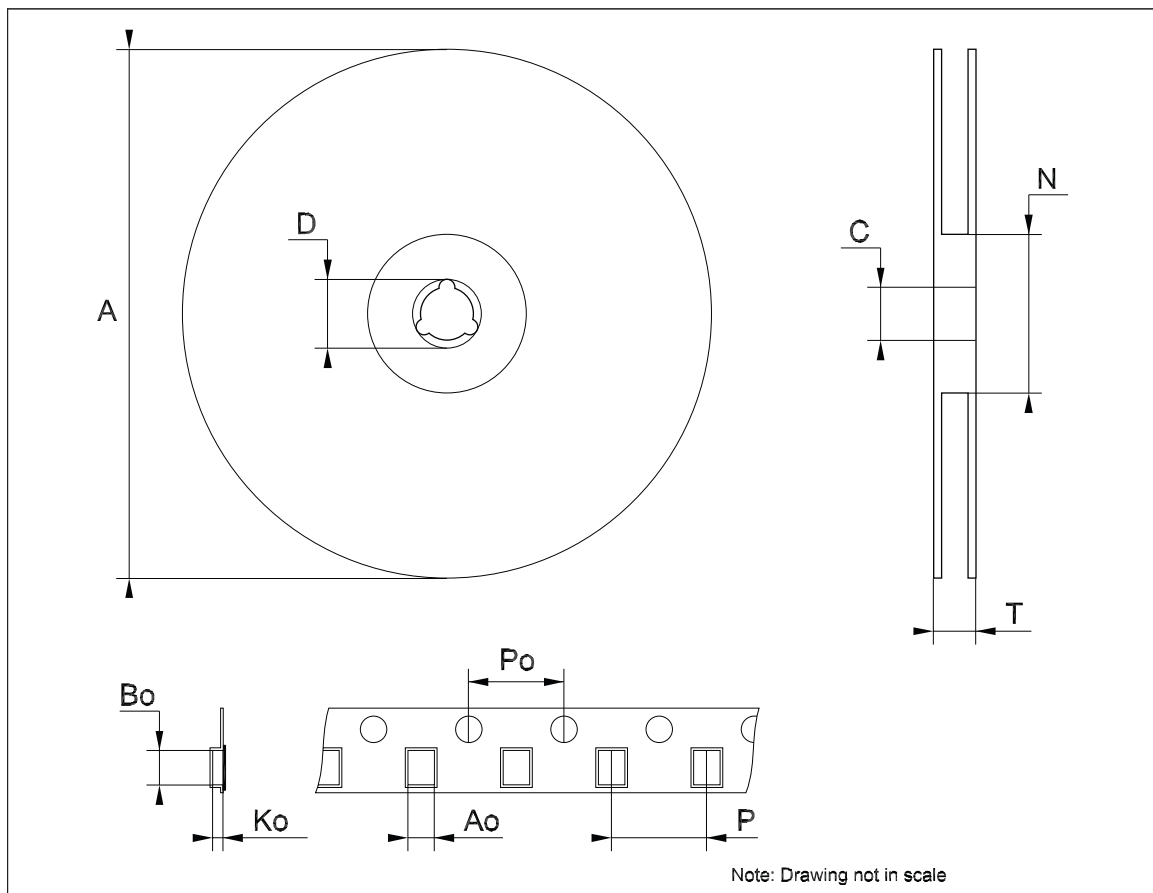

10 Revision history

Table 12. Document revision history

Date	Revision	Changes
27-Jan-2009	1	Initial release.
18-May-2009	2	Modified: Figure 3 on page 11 , Figure 4 on page 11 and Figure 5 on page 12 . Added: Z_{EXTM} Table 8 on page 19 .
09-Sep-2009	3	Modified: I_{IN} , A_{TONE} condition Table 8 on page 19 and Figure 5 on page 12 .
29-Nov-2010	4	Modified Table 10 on page 20 .

Please Read Carefully:

Information in this document is provided solely in connection with ST products. STMicroelectronics NV and its subsidiaries ("ST") reserve the right to make changes, corrections, modifications or improvements, to this document, and the products and services described herein at any time, without notice.

All ST products are sold pursuant to ST's terms and conditions of sale.

Purchasers are solely responsible for the choice, selection and use of the ST products and services described herein, and ST assumes no liability whatsoever relating to the choice, selection or use of the ST products and services described herein.

No license, express or implied, by estoppel or otherwise, to any intellectual property rights is granted under this document. If any part of this document refers to any third party products or services it shall not be deemed a license grant by ST for the use of such third party products or services, or any intellectual property contained therein or considered as a warranty covering the use in any manner whatsoever of such third party products or services or any intellectual property contained therein.

UNLESS OTHERWISE SET FORTH IN ST'S TERMS AND CONDITIONS OF SALE ST DISCLAIMS ANY EXPRESS OR IMPLIED WARRANTY WITH RESPECT TO THE USE AND/OR SALE OF ST PRODUCTS INCLUDING WITHOUT LIMITATION IMPLIED WARRANTIES OF MERCHANTABILITY, FITNESS FOR A PARTICULAR PURPOSE (AND THEIR EQUIVALENTS UNDER THE LAWS OF ANY JURISDICTION), OR INFRINGEMENT OF ANY PATENT, COPYRIGHT OR OTHER INTELLECTUAL PROPERTY RIGHT.

UNLESS EXPRESSLY APPROVED IN WRITING BY AN AUTHORIZED ST REPRESENTATIVE, ST PRODUCTS ARE NOT RECOMMENDED, AUTHORIZED OR WARRANTED FOR USE IN MILITARY, AIR CRAFT, SPACE, LIFE SAVING, OR LIFE SUSTAINING APPLICATIONS, NOR IN PRODUCTS OR SYSTEMS WHERE FAILURE OR MALFUNCTION MAY RESULT IN PERSONAL INJURY, DEATH, OR SEVERE PROPERTY OR ENVIRONMENTAL DAMAGE. ST PRODUCTS WHICH ARE NOT SPECIFIED AS "AUTOMOTIVE GRADE" MAY ONLY BE USED IN AUTOMOTIVE APPLICATIONS AT USER'S OWN RISK.

Resale of ST products with provisions different from the statements and/or technical features set forth in this document shall immediately void any warranty granted by ST for the ST product or service described herein and shall not create or extend in any manner whatsoever, any liability of ST.

ST and the ST logo are trademarks or registered trademarks of ST in various countries.

Information in this document supersedes and replaces all information previously supplied.

The ST logo is a registered trademark of STMicroelectronics. All other names are the property of their respective owners.

© 2010 STMicroelectronics - All rights reserved

STMicroelectronics group of companies

Australia - Belgium - Brazil - Canada - China - Czech Republic - Finland - France - Germany - Hong Kong - India - Israel - Italy - Japan - Malaysia - Malta - Morocco - Philippines - Singapore - Spain - Sweden - Switzerland - United Kingdom - United States of America

www.st.com

