

Low voltage, low current power 8-bit shift register

Features

- Low voltage power supply down to 3 V
- 8 constant current output channels
- Adjustable output current through external resistor
- Serial data IN/parallel data OUT
- 3.3 V micro driver-able
- Output current: 5-100 mA
- 30 MHz clock frequency
- Available in high thermal efficiency TSSOP exposed pad
- ESD protection 2.5 kV HBM, 200 V MM

Description

The STP08CP05 is a monolithic, low voltage, low current, power 8-bit shift register designed for LED panel displays. The STP08CP05 contains an 8-bit serial-in, parallel-out shift register that feeds an 8-bit D-type storage register. In the output stage, eight regulated current sources were designed to provide 5-100 mA constant current to drive the LEDs, the output current setup time is 11 ns (typ), thus improving the system performance.

The STP08CP05 is backward compatible in functionality and footprint with STP8C/L596. Through an external resistor, users can adjust the STP08CP05 output current, controlling in this way the light intensity of LEDs, in addition, user can

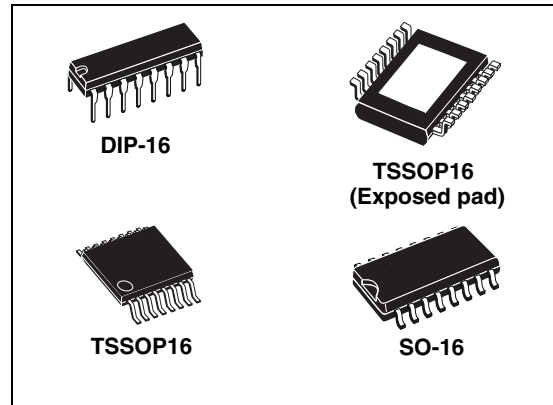

adjust LED's brightness intensity from 0% to 100% via \overline{OE} pin.

The STP08CP05 guarantees a 20 V output driving capability, allowing users to connect more LEDs in series. The high clock frequency, 30 MHz, also satisfies the system requirement of high volume data transmission. The 3.3 V of voltage supply is useful for applications that interface with any micro from 3.3 V. Compared with a standard TSSOP package, the TSSOP exposed pad increases heat dissipation capability by a 2.5 factor.

Table 1. Device summary

Order codes	Package	Packaging
STP08CP05B1R	DIP-16	25 parts per tube
STP08CP05MTR	SO-16 (Tape and reel)	2500 parts per reel
STP08CP05TTR	TSSOP16 (Tape and reel)	2500 parts per reel
STP08CP05XTTR	TSSOP16 exposed-pad (Tape and reel)	2500 parts per reel

Contents

1	Summary description	3
	1.1 Pin connection and description	3
2	Block diagram	4
3	Maximum rating	5
	3.1 Absolute maximum ratings	5
	3.2 Thermal data	5
	3.3 Recommended operating conditions	6
4	Electrical characteristics	7
5	Switching characteristics	8
6	Equivalent circuit and outputs	9
7	Truth table and timing diagram	11
	7.1 Truth table	11
	7.2 Timing diagram	12
8	Typical characteristics	15
9	Test circuit	18
10	Package mechanical data	20
11	Revision history	27

1 Summary description

Table 2. Typical current accuracy

Output voltage	Current accuracy		Output current
	Between bits	Between ICs	
≥ 1.3 V	$\pm 1.5\%$	$\pm 3\%$	20 to 100 mA

1.1 Pin connection and description

Figure 1. Connections diagram

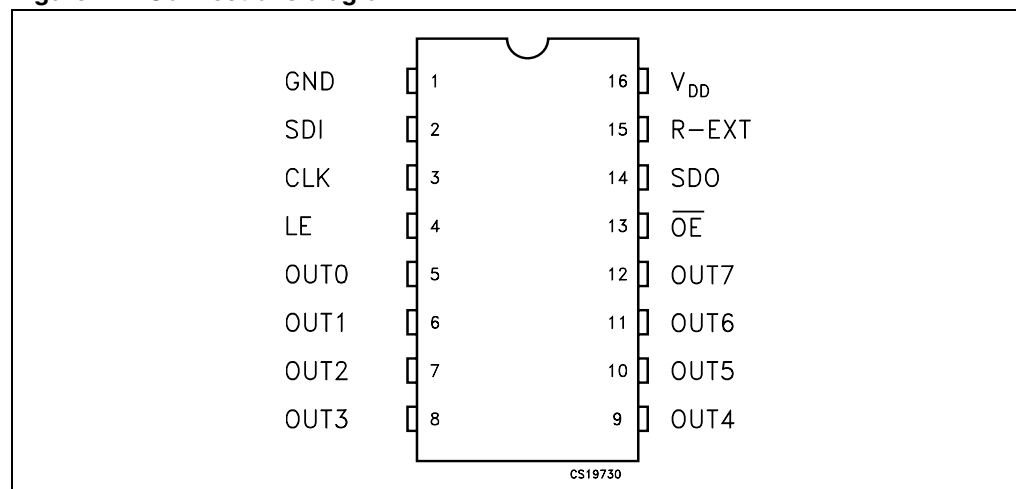

Note: The exposed pad should be electrically connected to a metal land electrically isolated or connected to ground.

Table 3. Pin description

Pin N°	Symbol	Name and function
1	GND	Ground terminal
2	SDI	Serial data input terminal
3	CLK	Clock input terminal
4	LE	Latch input terminal
5-12	OUT 0-7	Output terminal
13	$\overline{\text{OE}}$	Output enable input terminal (active low)
14	SDO	Serial data out terminal
15	R-EXT	Constant current programming
16	V_{DD}	5 V supply voltage terminal

2 Block diagram

Figure 2. Block diagram

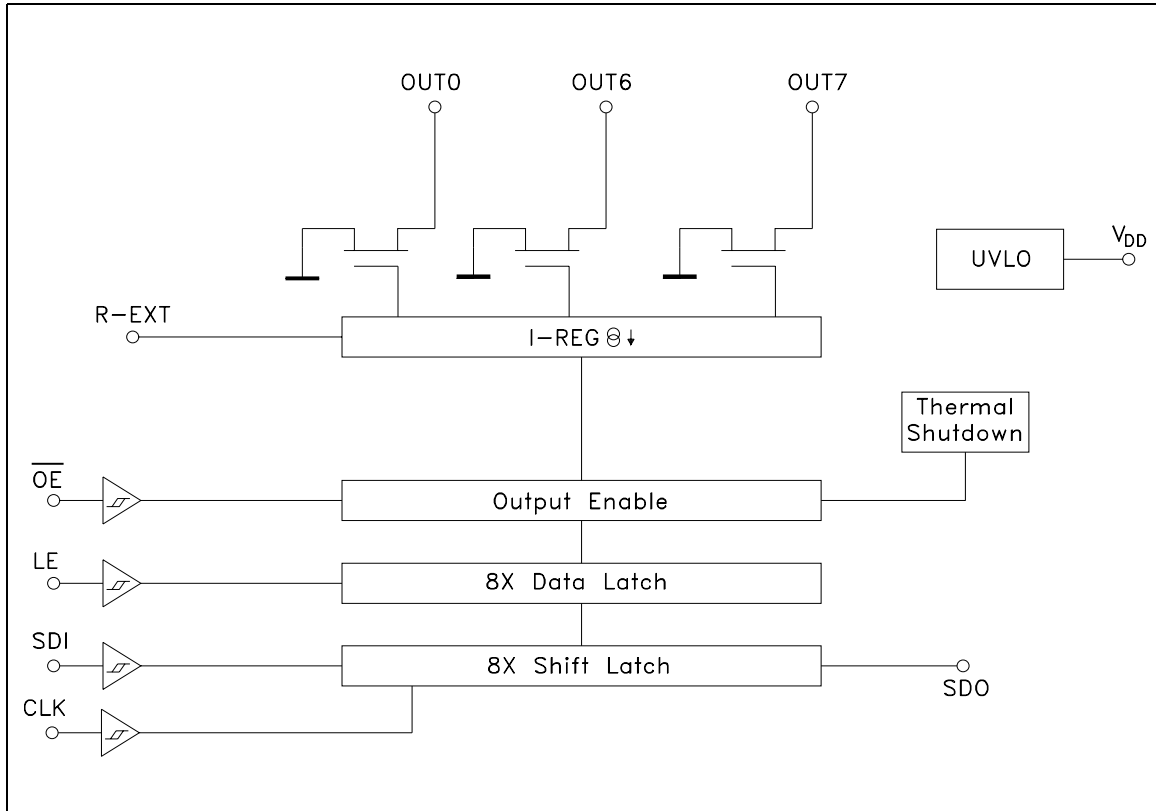

3 Maximum rating

Stressing the device above the rating listed in the “absolute maximum ratings” table may cause permanent damage to the device. These are stress ratings only and operation of the device at these or any other conditions above those indicated in the operating sections of this specification is not implied. Exposure to absolute maximum rating conditions for extended periods may affect device reliability.

3.1 Absolute maximum ratings

Table 4. Absolute maximum ratings

Symbol	Parameter	Value	Unit
V _{DD}	Supply voltage I _{GND}	0 to 7	V
V _O	Output voltage	-0.5 to 20	V
I _O	Output current	100	mA
I _{GND}	GND terminal current	800	mA
f _{CLK}	Clock frequency	50	MHz
T _{OPR}	Operating temperature range	-40 to +125	°C
T _{STG}	Storage temperature range	-55 to +150	°C

3.2 Thermal data

Table 5. Thermal data

Symbol	Parameter	DIP-16	SO-16	TSSOP-16	TSSOP-16 ⁽¹⁾ (exposed pad)	Unit
R _{thJA}	Thermal resistance junction-ambient	90	125	140	37.5	°C/W

1. The exposed-pad should be soldered to the PBC to realize the thermal benefits

3.3 Recommended operating conditions

Table 6. Recommended operating conditions

Symbol	Parameter	Test conditions	Min	Typ	Max	Unit
V_{DD}	Supply voltage		3.0		5.5	V
V_O	Output voltage				20	V
I_O	Output current	OUTn	5		100	mA
I_{OH}	Output current	SERIAL-OUT			+1	mA
I_{OL}	Output current	SERIAL-OUT			-1	mA
V_{IH}	Input voltage		$0.7 V_{DD}$		$V_{DD}+0.3$	V
V_{IL}	Input voltage		-0.3		$0.3 V_{DD}$	V
t_{wLAT}	LE pulse width	$V_{DD} = 3.0 \text{ to } 5.0 \text{ V}$	20			ns
t_{wCLK}	CLK pulse width		20			ns
t_{wEN}	\overline{OE} pulse width		200			ns
$t_{SETUP(D)}$	Setup time for DATA		7			ns
$t_{HOLD(D)}$	Hold time for DATA		4			ns
$t_{SETUP(L)}$	Setup time for LATCH		15			ns
f_{CLK}	Clock frequency		Cascade operation ⁽¹⁾			30

1. In order to achieve high cascade data transfer, please consider t_r/t_f timings carefully.

4 Electrical characteristics

$V_{DD} = 3.3 \text{ V to } 5 \text{ V}$, $T = 25 \text{ }^\circ\text{C}$, unless otherwise specified.

Table 7. Electrical characteristics

Symbol	Parameter	Test conditions	Min	Typ	Max	Unit
V_{IH}	Input voltage high level		$0.7 V_{DD}$		V_{DD}	V
V_{IL}	Input voltage low level		GND		$0.3V_{DD}$	V
I_{OH}	Output leakage current	$V_{OH} = 20 \text{ V}$		0.5	10	μA
V_{OL}	Output voltage (Serial-OUT)	$I_{OL} = 1 \text{ mA}$		0.03	0.4	V
V_{OH}	Output voltage (Serial-OUT)	$I_{OH} = -1 \text{ mA}$	$V_{OH} - V_{DD} = -0.4 \text{ V}$			V
I_{OL1}	Output current	$V_O = 0.3 \text{ V}$, $R_{ext} = 3.9 \text{ k}\Omega$	4.25	5	5.75	mA
I_{OL2}		$V_O = 0.3 \text{ V}$, $R_{ext} = 970 \text{ }\Omega$	19.4	20	20.6	
I_{OL3}		$V_O = 1.3 \text{ V}$, $R_{ext} = 190 \text{ }\Omega$	97	100	103	
ΔI_{OL1}	Output current error between bit (All Output ON)	$V_O = 0.3 \text{ V}$, $R_{EXT} = 3.9 \text{ k}\Omega$		± 5	± 8	%
ΔI_{OL2}		$V_O = 0.3 \text{ V}$, $R_{EXT} = 970 \text{ }\Omega$		± 1.5	± 2.75	
ΔI_{OL3}		$V_O = 1.3 \text{ V}$, $R_{EXT} = 190 \text{ }\Omega$		± 1.2	± 2.5	
$R_{SIN(up)}$	Pull-up resistor		150	300	600	$\text{K}\Omega$
$R_{SIN(down)}$	Pull-down resistor		100	200	400	$\text{K}\Omega$
$I_{DD(OFF1)}$	Supply current (OFF)	$R_{EXT} = 980$ OUT 0 to 7 = OFF		4	5	mA
$I_{DD(OFF2)}$		$R_{EXT} = 250$ OUT 0 to 7 = OFF		11.2	13.5	
$I_{DD(ON1)}$	Supply current (ON)	$R_{EXT} = 980$ OUT 0 to 7 = ON		4.5	5	
$I_{DD(ON2)}$		$R_{EXT} = 250$ OUT 0 to 7 = ON		11.7	13.5	
Thermal	Thermal protection ⁽¹⁾			170		$^\circ\text{C}$

1. Guaranteed by design (not tested)
The thermal protection switches OFF only the outputs

5 Switching characteristics

$V_{DD} = 5\text{ V}$, $T = 25\text{ °C}$, unless otherwise specified.

Table 8. Switching characteristics

Symbol	Parameter	Test conditions	Min	Typ	Max	Unit		
t_{PLH1}	Propagation delay time, CLK- $\overline{\text{OUTn}}$, LE = H, $\overline{\text{OE}} = \text{L}$		$V_{DD} = 3.3\text{ V}$		35	50	ns	
			$V_{DD} = 5\text{ V}$		18	28		
t_{PLH2}	Propagation delay time, LE - $\overline{\text{OUTn}}$, $\overline{\text{OE}} = \text{L}$		$V_{DD} = 3.3\text{ V}$		48	74	ns	
			$V_{DD} = 5\text{ V}$		30	50		
t_{PLH3}	Propagation delay time, $\overline{\text{OE}} - \overline{\text{OUTn}}$, LE = H		$V_{DD} = 3.3\text{ V}$		55	82	ns	
			$V_{DD} = 5\text{ V}$		37	58		
t_{PLH}	Propagation delay time, CLK-SDO		$V_{DD} = 3.3\text{ V}$		21	28	ns	
			$V_{DD} = 5\text{ V}$		17	22		
t_{PHL1}	Propagation delay time, CLK- $\overline{\text{OUTn}}$, LE = H, $\overline{\text{OE}} = \text{L}$	$V_{DD} = 3.3\text{ V}$ $V_{IL} = \text{GND}$ $I_O = 20\text{ mA}$ $R_{EXT} = 1\text{ K}\Omega$	$V_{IH} = V_{DD}$ $C_L = 10\text{ pF}$ $V_L = 3.0\text{ V}$ $R_L = 60\ \Omega$	$V_{DD} = 3.3\text{ V}$		11	17	ns
				$V_{DD} = 5\text{ V}$		7	11	
t_{PHL2}	Propagation delay time, LE - $\overline{\text{OUTn}}$, $\overline{\text{OE}} = \text{L}$			$V_{DD} = 3.3\text{ V}$		24	40	ns
				$V_{DD} = 5\text{ V}$		21	31	
t_{PHL3}	Propagation delay time, $\overline{\text{OE}} - \overline{\text{OUTn}}$, LE = H			$V_{DD} = 3.3\text{ V}$		20	35	ns
				$V_{DD} = 5\text{ V}$		18	28	
t_{PHL}	Propagation delay time, CLK-SDO			$V_{DD} = 3.3\text{ V}$		24	32	ns
				$V_{DD} = 5\text{ V}$		19	25	
t_{ON}	Output rise time 10~90% of voltage waveform			$V_{DD} = 3.3\text{ V}$		26	40	ns
				$V_{DD} = 5\text{ V}$		11	17	
t_{OFF}	Output fall time 90~10% of voltage waveform			$V_{DD} = 3.3\text{ V}$		5	10	ns
				$V_{DD} = 5\text{ V}$		4	8	
t_r	CLK rise time ⁽¹⁾					5000	ns	
t_f	CLK fall time ⁽¹⁾					5000	ns	

1. In order to achieve high cascade data transfer, please consider t_r/t_f timings carefully.



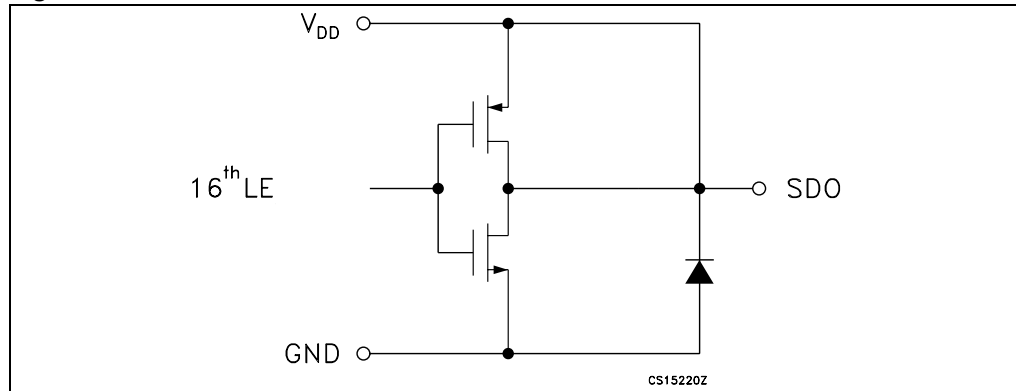

Figure 6. SDO terminal



7 Truth table and timing diagram

7.1 Truth table

Table 9. Truth table

Clock	LE	\overline{OE}	SDI	$\overline{OUT0}$ $\overline{OUT0}$ $\overline{OUT7}$	SDO
	H	L	Dn	Dn Dn -5 Dn -7	Dn -7
	L	L	Dn + 1	No change	Dn -7
	H	L	Dn + 2	$\overline{Dn + 2}$ $\overline{Dn - 3}$ $\overline{Dn - 5}$	Dn -5
	X	L	Dn + 3	$\overline{Dn + 2}$ $\overline{Dn - 3}$ $\overline{Dn - 5}$	Dn -5
	X	H	Dn + 3	OFF	Dn -5

Note: $OUT0$ to $OUT7 = ON$ when $Dn = H$; $OUT0$ to $OUT7 = OFF$ when $Dn = L$.

7.2 Timing diagram

Figure 7. Timing diagram

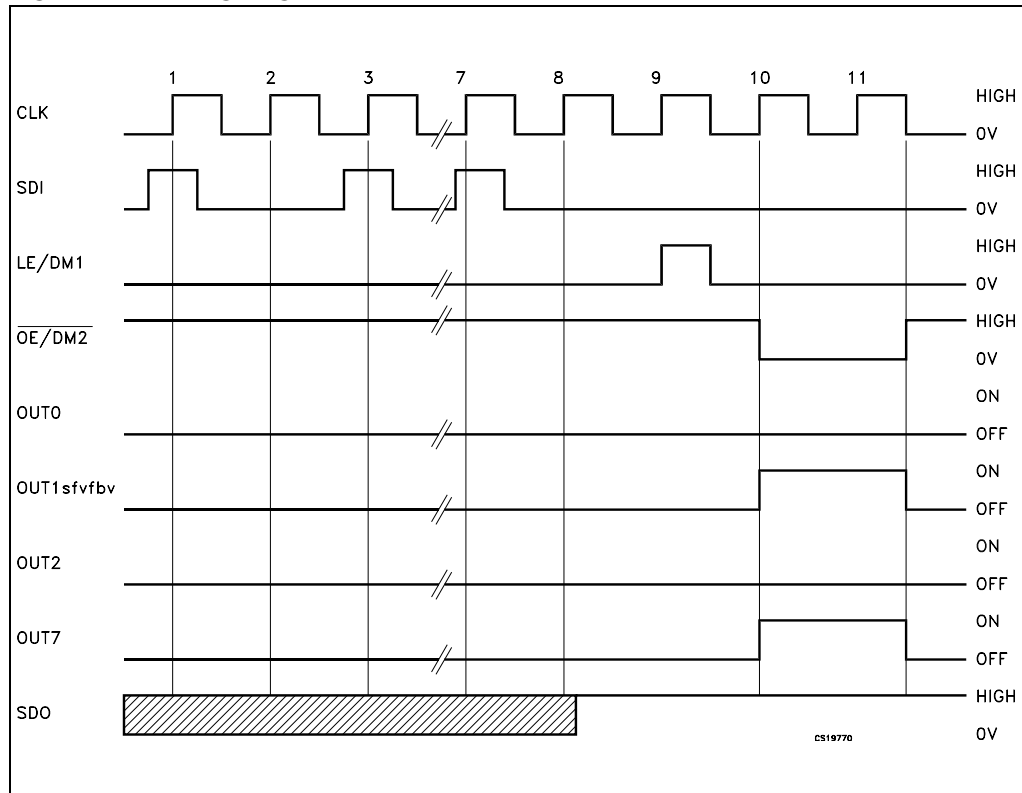

Figure 8. Clock, serial-in, serial-out

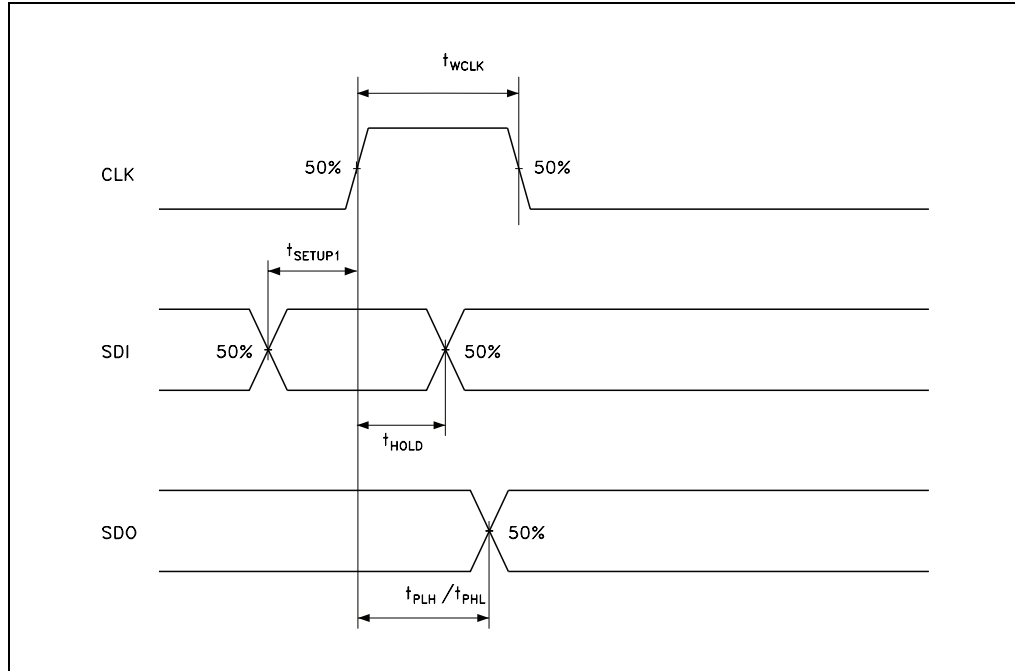

Figure 9. Clock, serial-in, latch, enable, outputs

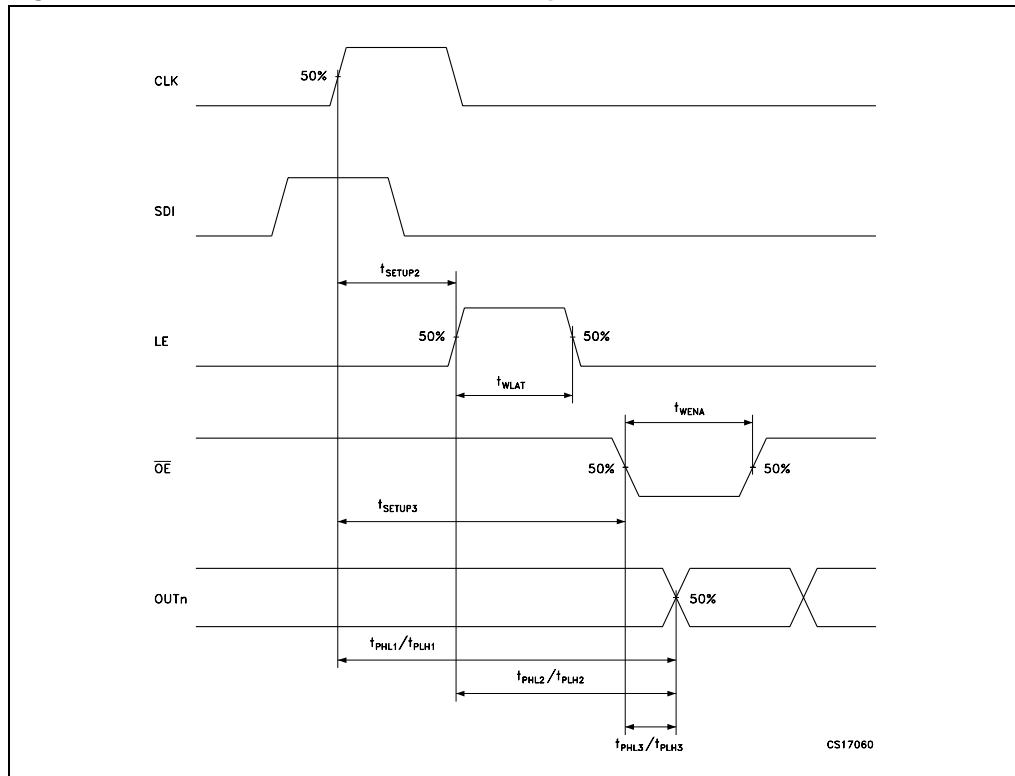
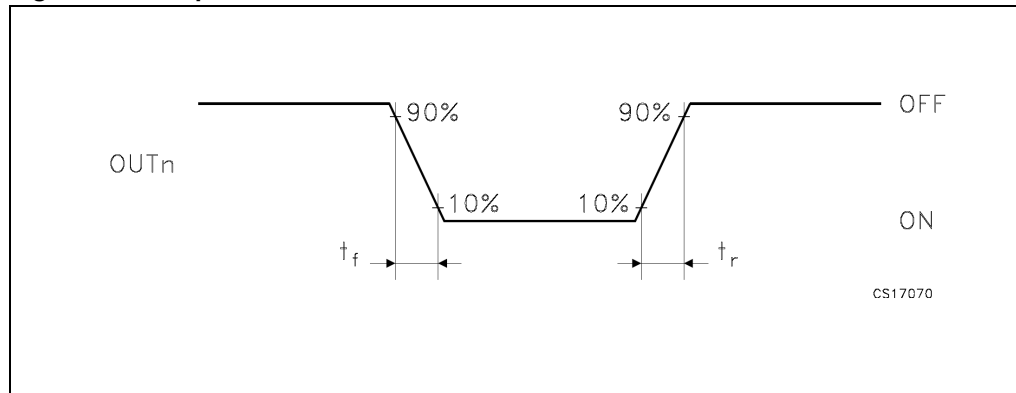

Figure 10. Outputs



8 Typical characteristics

Figure 11. Output current- R_{EXT} resistor

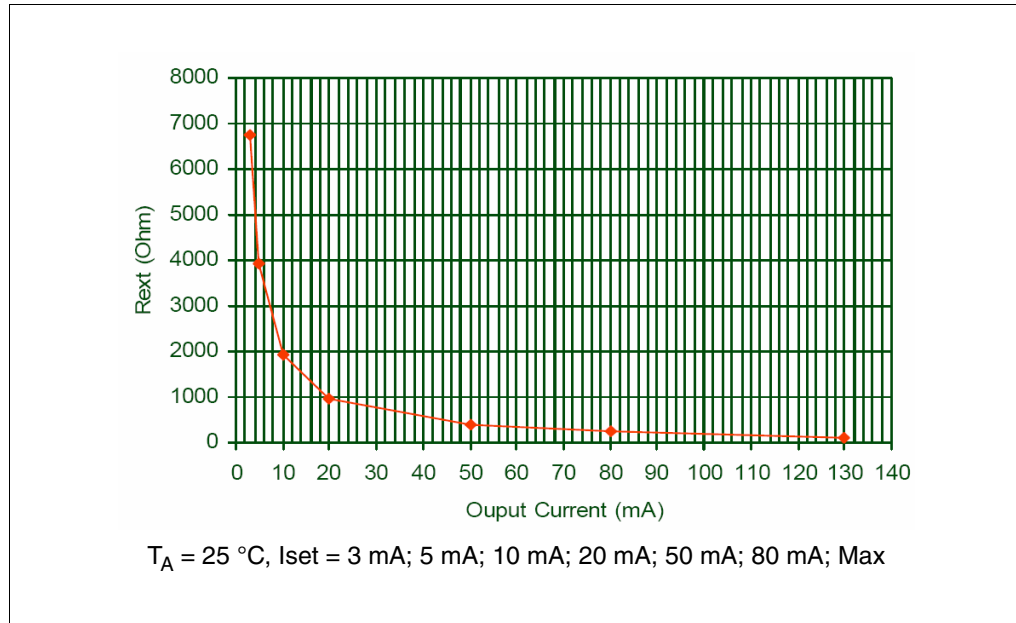

Table 10. Output current- R_{EXT} resistor

Output current (mA)	3	5	10	20	50	80	130
R_{ext} (Ω)	6740	3930	1913	963	386	241	124

Note: Maximum output current capabilities setting was 130 mA applying an $R_{ext} = 124\ \Omega$

Figure 12. I_{SET} vs drop out voltage (V_{DROP})

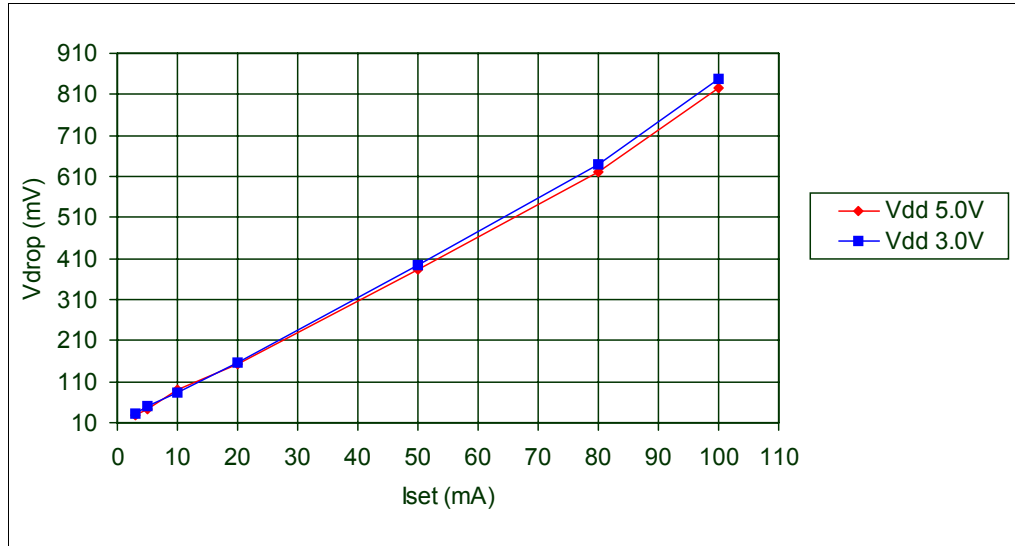
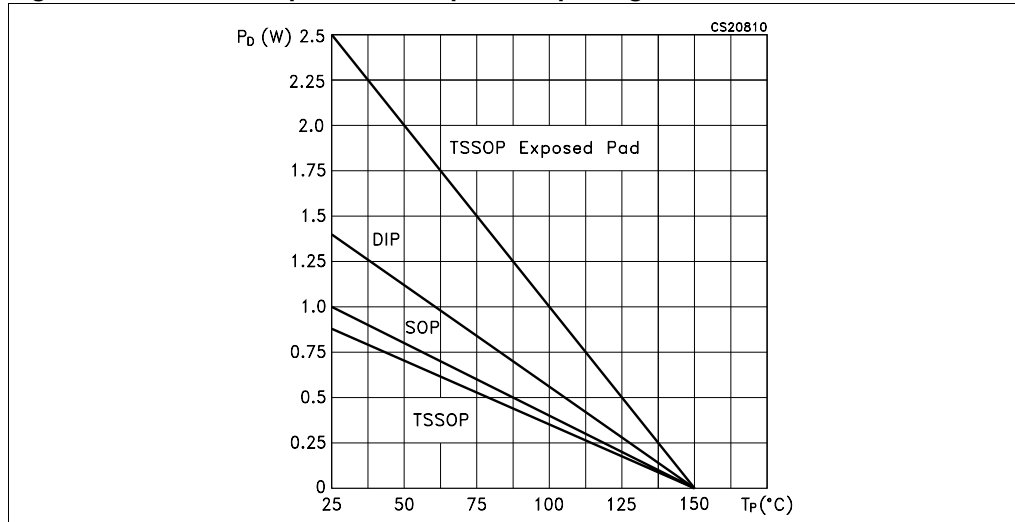

Table 11. I_{SET} vs drop out voltage (V_{DROP})

Vdd (V)	I set (mA)	Rext (Ω)	Vdrop min (mV)	Vdrop max (mV)	Vdrop AVG (mV)
3	3	6470	30.6	31.2	30.93
	5	3930	46.5	52.9	48.63
	10	1910	80.9	100	82.26
	20	963	150	161	157
	50	386	392	396	394.3
	80	241	636	646	640.3
	100	192	846	850	848
5	3	6470	25.6	29	26.96
	5	3930	40.8	41.7	41.16
	10	1910	80.1	105	89.2
	20	963	153	154	154
	50	386	379	386	382
	80	241	618	626	621
	100	192	825	830	827

Figure 13. Power dissipation vs temperature package



Note: The exposed-pad should be soldered to the PBC to realize the thermal benefits.

Figure 14. Current precision between outputs vs output current

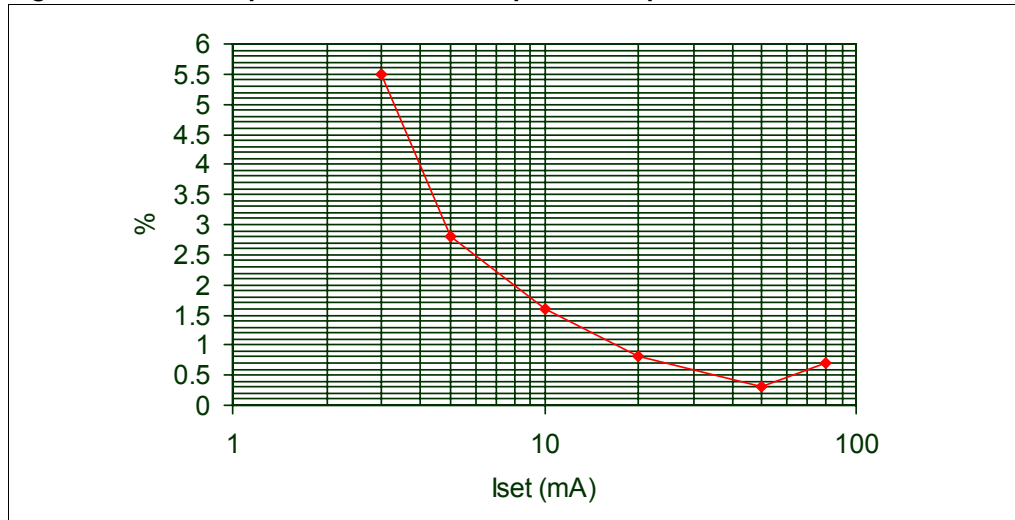

9 Test circuit

Figure 15. DC characteristics

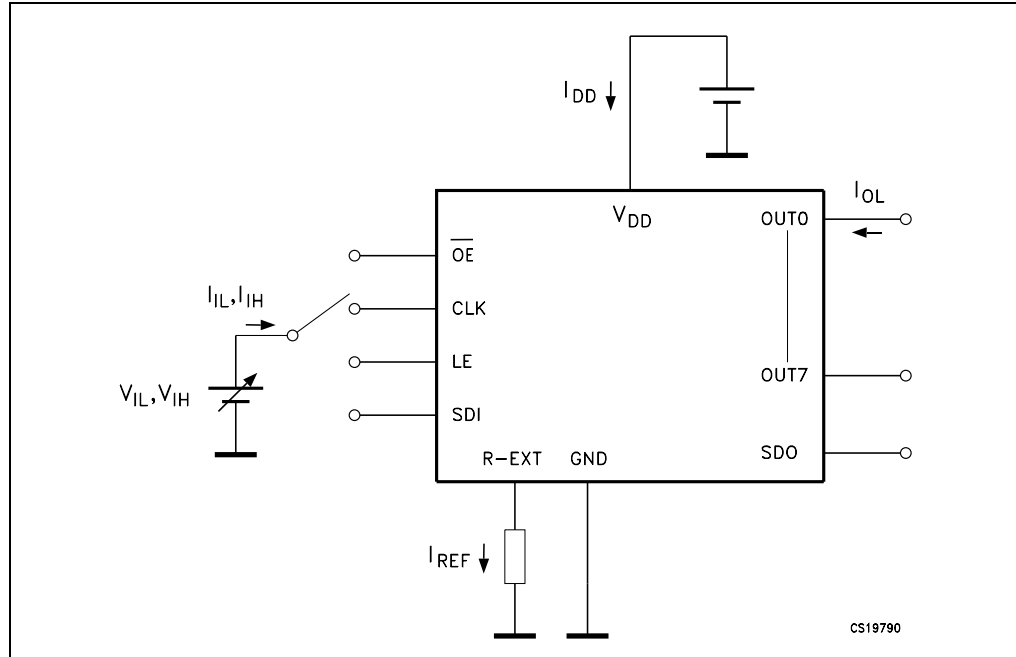

Figure 16. AC characteristics

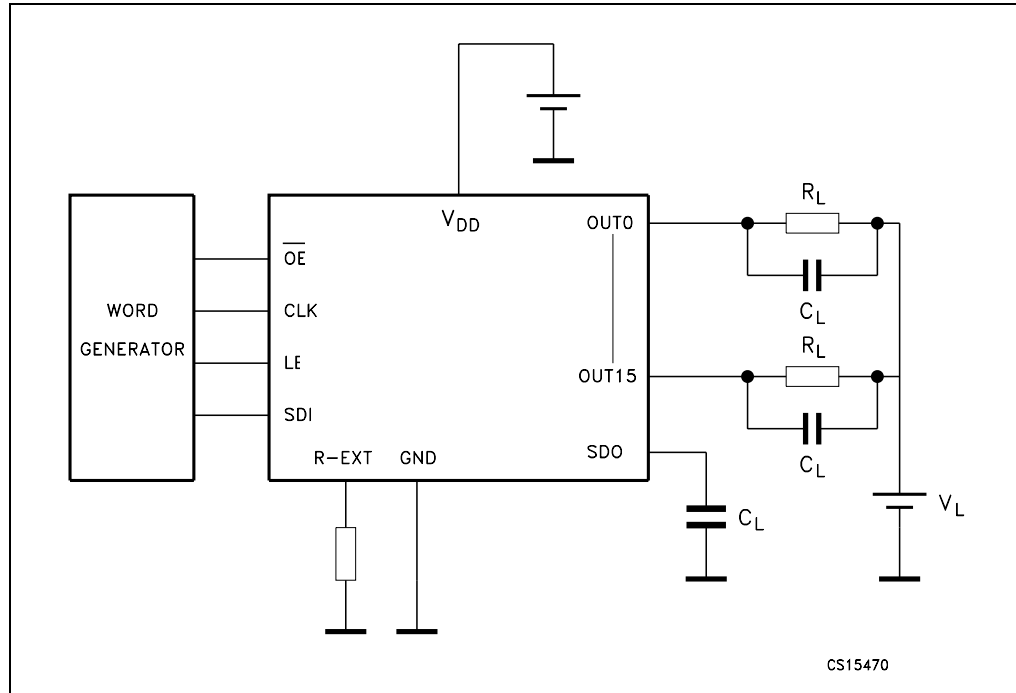
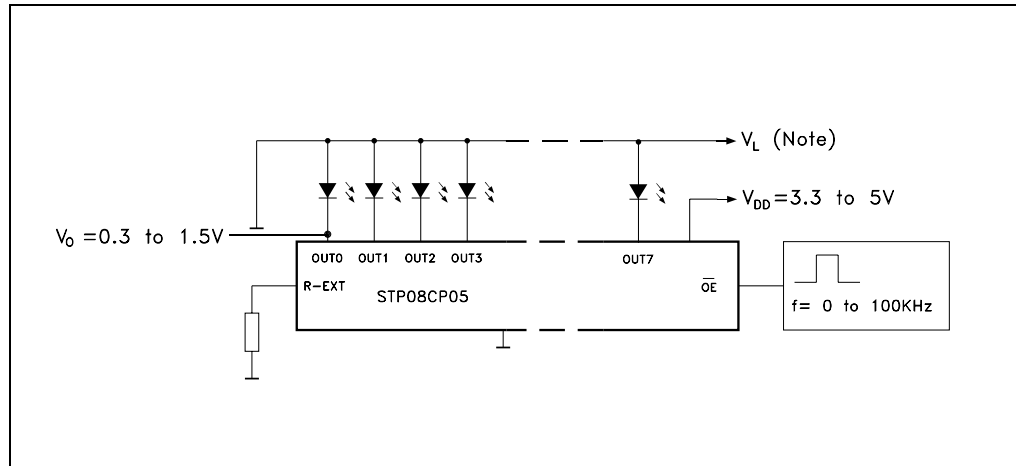

Figure 17. Typical application schematic



10 Package mechanical data

In order to meet environmental requirements, ST offers these devices in different grades of ECOPACK[®] packages, depending on their level of environmental compliance. ECOPACK[®] specifications, grade definitions and product status are available at: www.st.com. ECOPACK is an ST trademark.

Figure 18. DIP-16 mechanical data

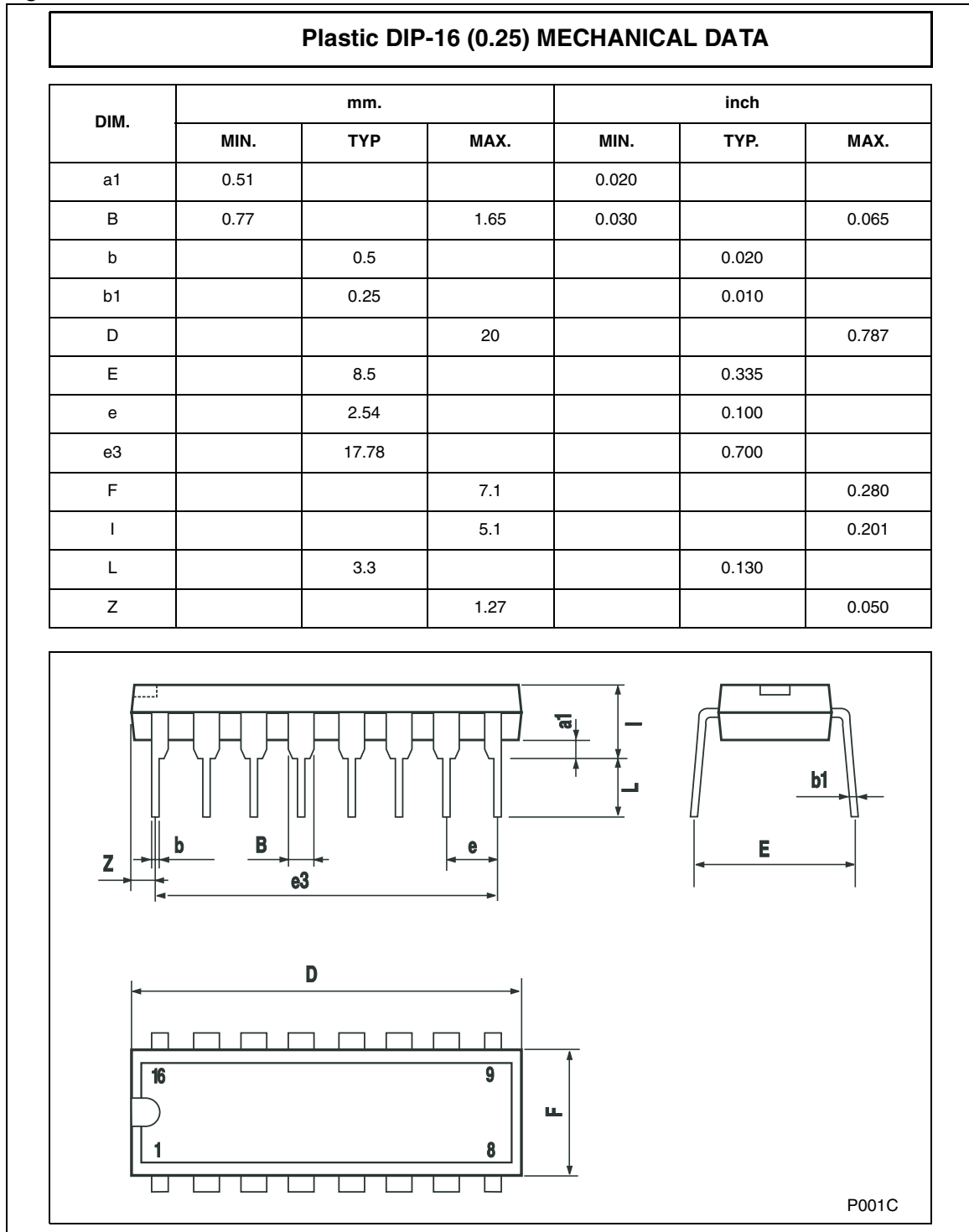

Figure 19. TSSOP16 mechanical data

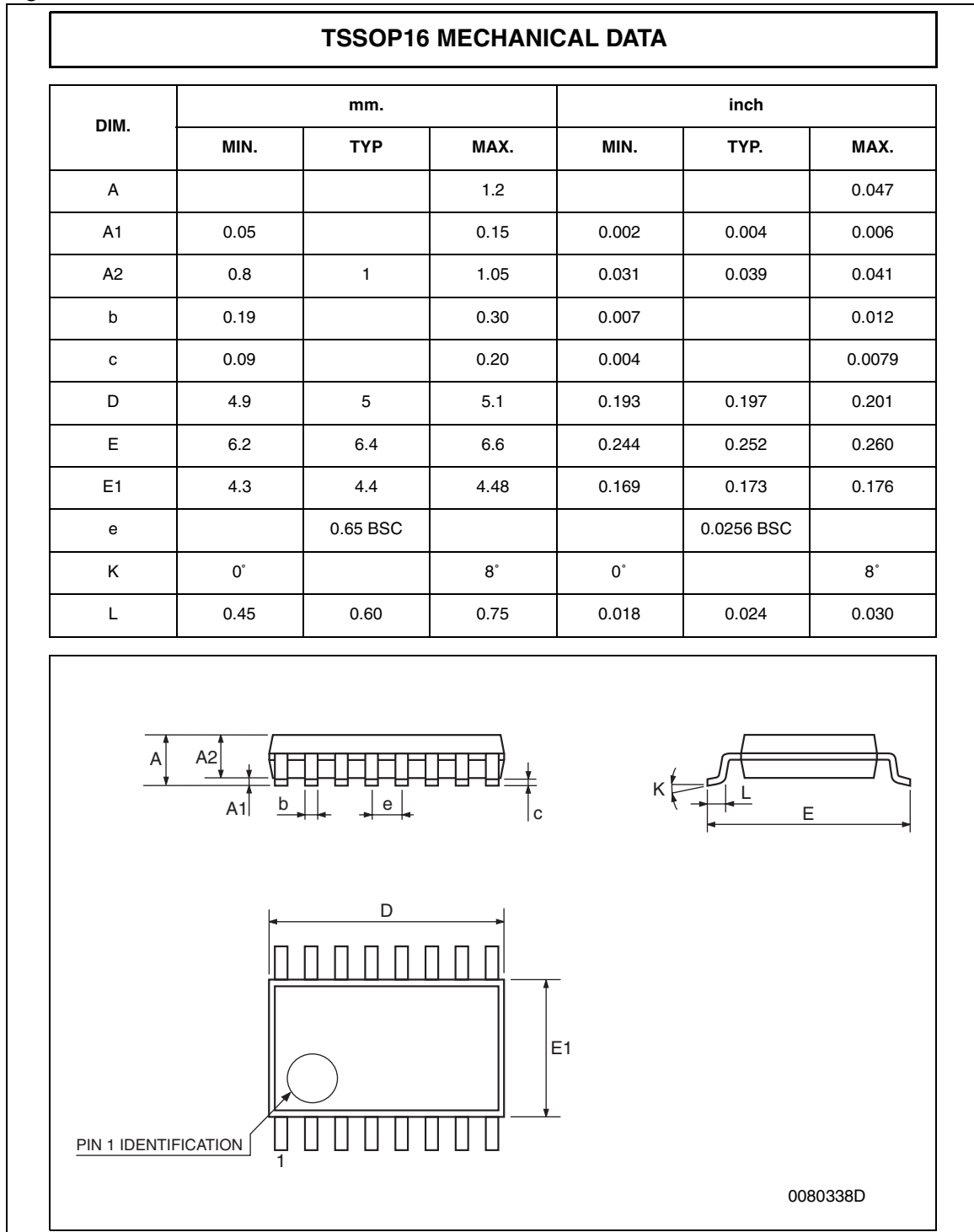

Figure 20. TSSOP16 exposed pad mechanical data

TSSOP16 EXPOSED PAD MECHANICAL DATA						
DIM.	mm.			inch		
	MIN.	TYP	MAX.	MIN.	TYP.	MAX.
A			1.2			0.047
A1			0.15		0.004	0.006
A2	0.8	1	1.05	0.031	0.039	0.041
b	0.19		0.30	0.007		0.012
c	0.09		0.20	0.004		0.0089
D	4.9	5	5.1	0.193	0.197	0.201
D1	2.7	3.0	3.3			
E	6.2	6.4	6.6	0.244	0.252	0.260
E1	4.3	4.4	4.5	0.169	0.173	0.177
E2	2.7	3.0	3.3			
e		0.65			0.0256	
K	0°		8°	0°		8°
L	0.45	0.60	0.75	0.018	0.024	0.030

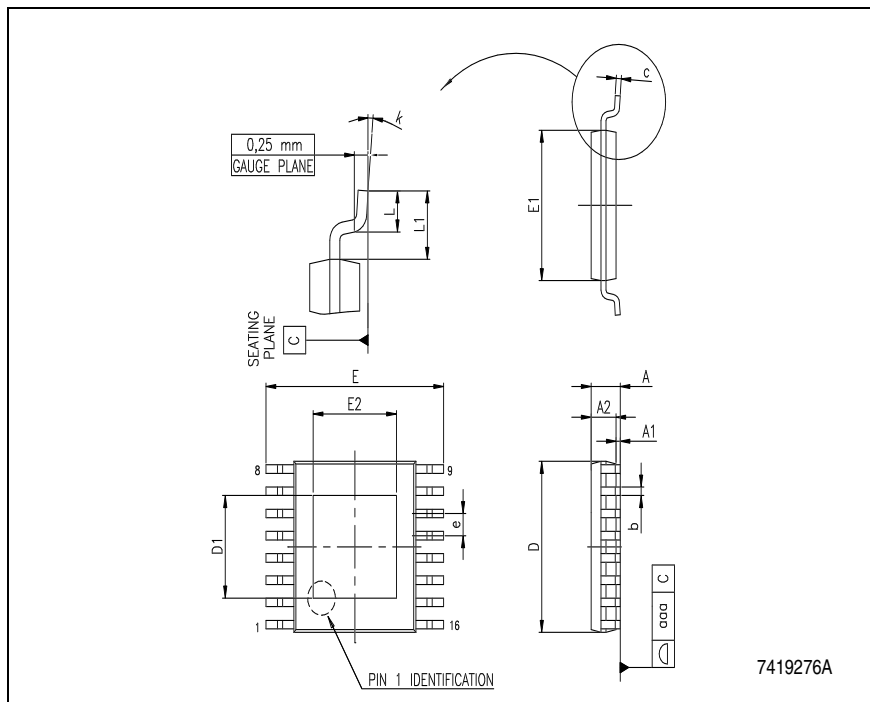

Figure 21. TSSOP16 tape and reel

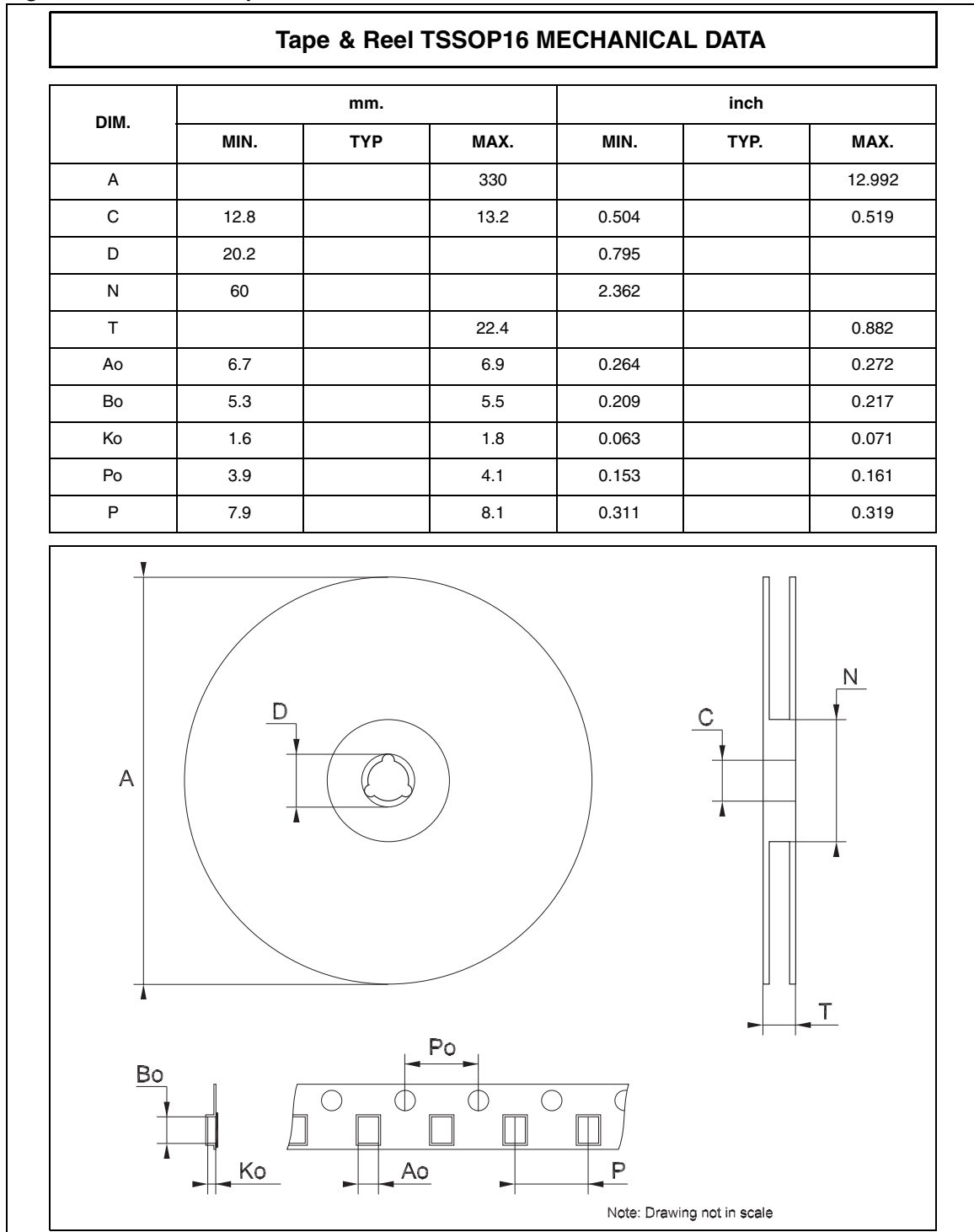

Figure 22. SO-16 mechanical data

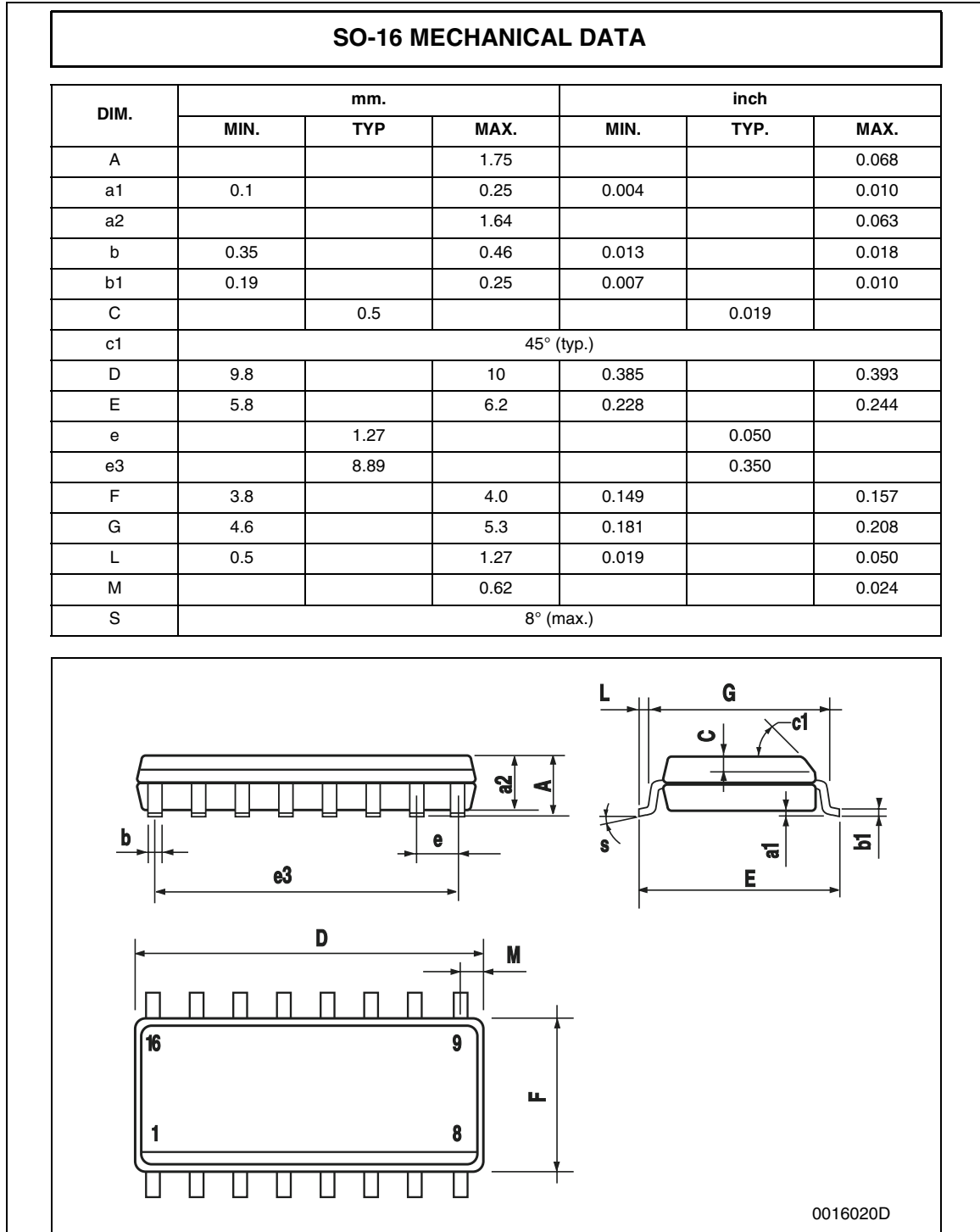
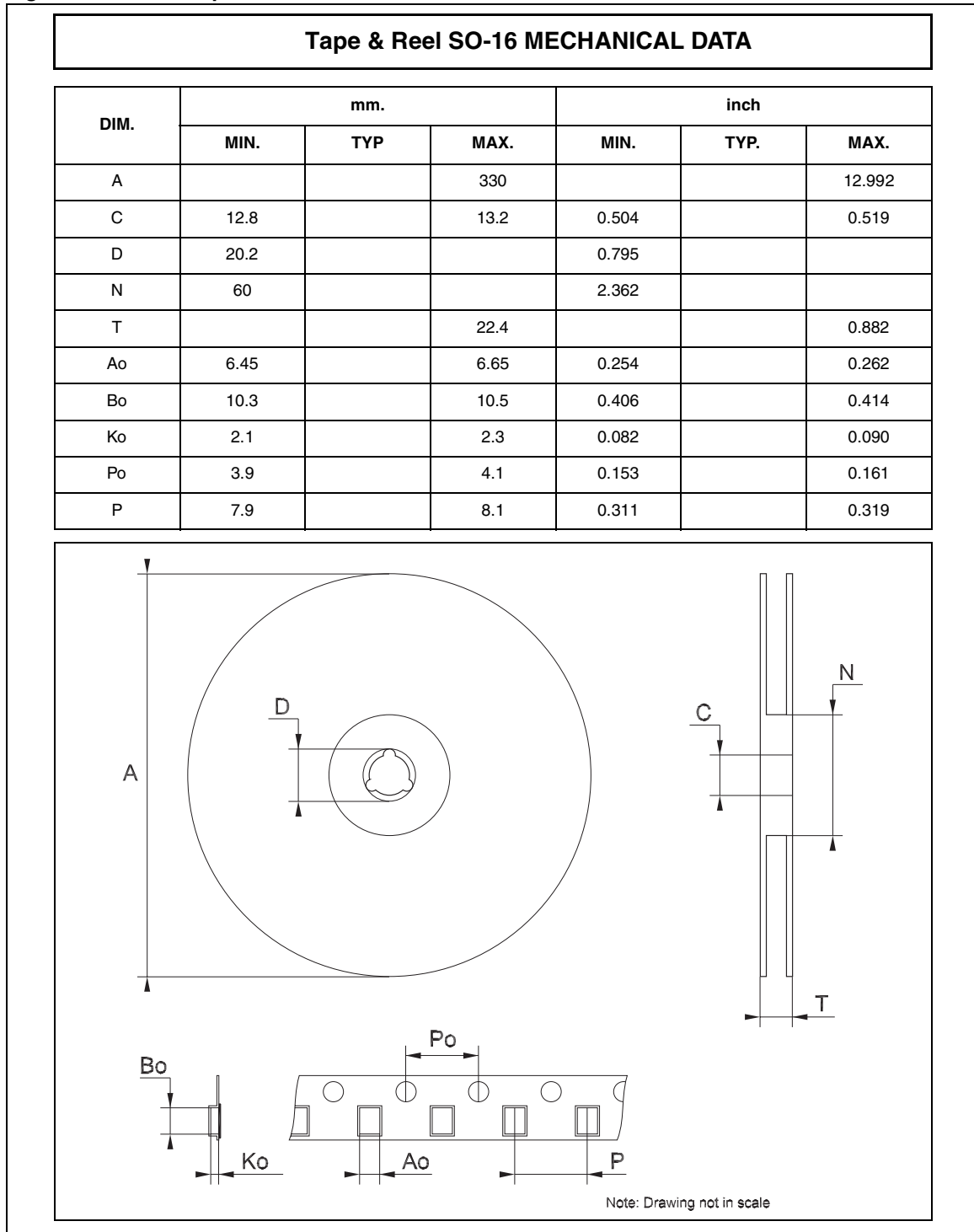

Figure 23. SO-16 tape and reel



11 Revision history

Table 12. Document revision history

Date	Revision	Changes
23-May-2007	1	First release
28-Jun-2007	2	Updated Table 7 on page 7
12-Mar-2008	3	Updated Table 8 on page 8 and added Figure 11 and Figure 12 on page 16
07-Aug-2008	4	Updated Section 8: Typical characteristics on page 15
27-Aug-2010	5	Updated Note: on page 3

Please Read Carefully:

Information in this document is provided solely in connection with ST products. STMicroelectronics NV and its subsidiaries ("ST") reserve the right to make changes, corrections, modifications or improvements, to this document, and the products and services described herein at any time, without notice.

All ST products are sold pursuant to ST's terms and conditions of sale.

Purchasers are solely responsible for the choice, selection and use of the ST products and services described herein, and ST assumes no liability whatsoever relating to the choice, selection or use of the ST products and services described herein.

No license, express or implied, by estoppel or otherwise, to any intellectual property rights is granted under this document. If any part of this document refers to any third party products or services it shall not be deemed a license grant by ST for the use of such third party products or services, or any intellectual property contained therein or considered as a warranty covering the use in any manner whatsoever of such third party products or services or any intellectual property contained therein.

UNLESS OTHERWISE SET FORTH IN ST'S TERMS AND CONDITIONS OF SALE ST DISCLAIMS ANY EXPRESS OR IMPLIED WARRANTY WITH RESPECT TO THE USE AND/OR SALE OF ST PRODUCTS INCLUDING WITHOUT LIMITATION IMPLIED WARRANTIES OF MERCHANTABILITY, FITNESS FOR A PARTICULAR PURPOSE (AND THEIR EQUIVALENTS UNDER THE LAWS OF ANY JURISDICTION), OR INFRINGEMENT OF ANY PATENT, COPYRIGHT OR OTHER INTELLECTUAL PROPERTY RIGHT.

UNLESS EXPRESSLY APPROVED IN WRITING BY AN AUTHORIZED ST REPRESENTATIVE, ST PRODUCTS ARE NOT RECOMMENDED, AUTHORIZED OR WARRANTED FOR USE IN MILITARY, AIR CRAFT, SPACE, LIFE SAVING, OR LIFE SUSTAINING APPLICATIONS, NOR IN PRODUCTS OR SYSTEMS WHERE FAILURE OR MALFUNCTION MAY RESULT IN PERSONAL INJURY, DEATH, OR SEVERE PROPERTY OR ENVIRONMENTAL DAMAGE. ST PRODUCTS WHICH ARE NOT SPECIFIED AS "AUTOMOTIVE GRADE" MAY ONLY BE USED IN AUTOMOTIVE APPLICATIONS AT USER'S OWN RISK.

Resale of ST products with provisions different from the statements and/or technical features set forth in this document shall immediately void any warranty granted by ST for the ST product or service described herein and shall not create or extend in any manner whatsoever, any liability of ST.

ST and the ST logo are trademarks or registered trademarks of ST in various countries.

Information in this document supersedes and replaces all information previously supplied.

The ST logo is a registered trademark of STMicroelectronics. All other names are the property of their respective owners.

© 2010 STMicroelectronics - All rights reserved

STMicroelectronics group of companies

Australia - Belgium - Brazil - Canada - China - Czech Republic - Finland - France - Germany - Hong Kong - India - Israel - Italy - Japan - Malaysia - Malta - Morocco - Philippines - Singapore - Spain - Sweden - Switzerland - United Kingdom - United States of America

www.st.com