

DRAWING MADE IN THIRD ANGLE PROJECTION

THIS DRAWING IS UNPUBLISHED. RELEASED FOR PUBLICATION, 19 .

© COPYRIGHT 19 BY AMP INCORPORATED. ALL INTERNATIONAL RIGHTS RESERVED.

LOC	DIST	P	F	ZONE	LTR	DESCRIPTION	DATE	APPD
G	14				E	REV / 0720-0612-95	31MAY95	SB

PART NO	PACKAGE TYPE	QTY
8-55793-2	LOOSE PIECE, BOX	50
8-55793-4	LOOSE PIECE, BLS	5
9-55793-4	LOOSE PIECE, BLS	25

1. WIRE INSUL DIA, 3.81-6.35 [ .150-.230 ]

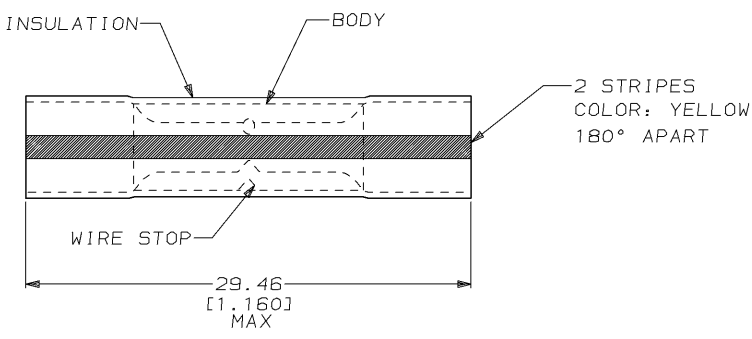

1500	ON TAPE, REEL	BODY, COPPER PER ASTM B-152 TIN PL 0.00254 [ .000100 ] MIN THK PER MIL-T-10727	55793-2
500	LOOSE PIECE	INSULATION, VINYL COLOR, TRANSPARENT	55793-1
QTY	PACKAGE TYPE	MATERIAL & FINISH	PART NO
DO NOT SCALE PRINT. UNLESS SPECIFIED DIMENSIONS IN mm [INCHES] TOLERANCES ON: 2 PLC DEC ± - 3 PLC DEC ± - ANGLES ± -		DR 10/8/90 DK SCHUBH CHK 10/9/90 NS FEHER APPD 10/10/90 PJ RUELUS APPD 10/12/90 M BARNABA PRODUCT SPEC UL 486A	AMP Incorporated Harrisburg, PA 17105-3608
MATERIAL SEE TABLE		NAME SPLICE, BUTT, PLASTI-GRIP™ WIRE SIZE, 12-10 AWG	
FINISH SEE TABLE		SIZE B	CAGE CODE 00779
		APPLICATION SPEC -	DRAWING NO C=55793
		WEIGHT -	SCALE 4:1
			SHEET 1 OF 1

THIS DRAWING IS A CONTROLLED DOCUMENT FOR AMP INCORPORATED. IT IS SUBJECT TO CHANGE AND THE CONTROLLING ENGINEERING ORGANIZATION SHOULD BE CONTACTED FOR THE LATEST REVISION.

AMP 1470-15 REV 3-92  
05 MAY 1995 15:21:00 AMP10398 <UU128A>DEPT1132>U.DWG1132>U.RBY>U.PLASTI-GRIP>U.CUST

CUSTOMER DRAWING