

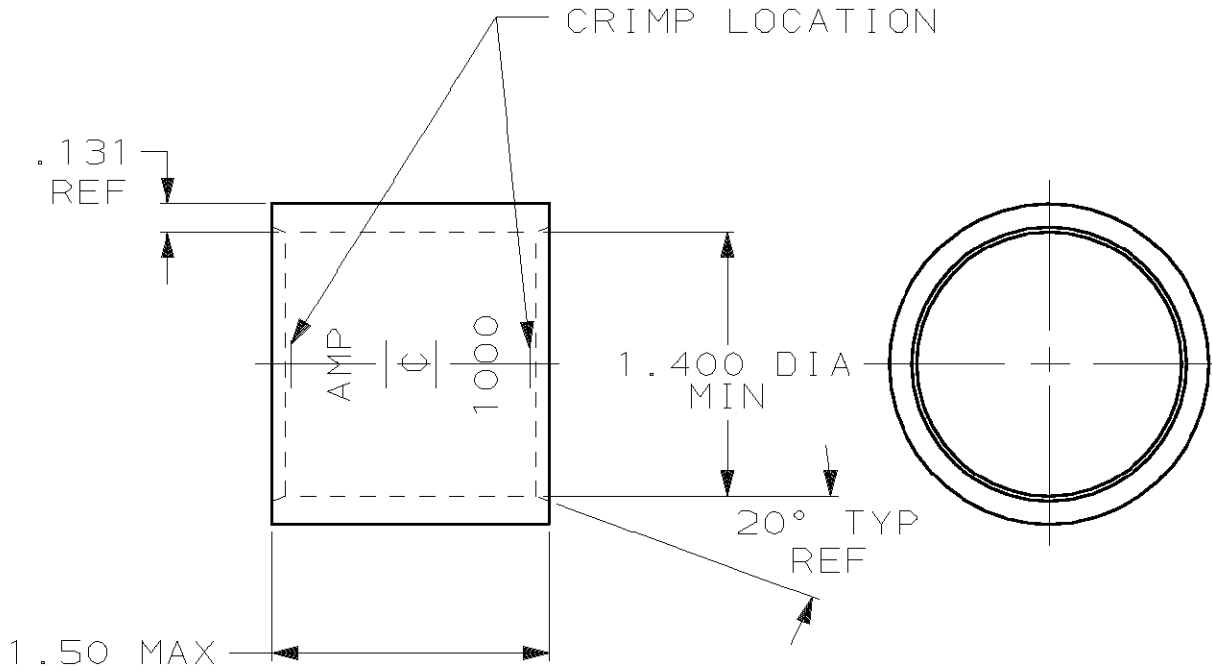

LOC G	DIST 86	P	F	REVISIONS		
		LTR		DESCRIPTION	DATE	APPROVED
		F		REV PER 0G3A-0637-01	030CT02	JR/MS

1 PREPRODUCTION - FASR REQ



950-1,125 MCM	CLEANED, UNPLATED	1-324456-0
	TIN PL PER ASTM B545 .000150 MIN THK	324456
RANGE	FINISH	PART NO

DO NOT SCALE PRINT.
UNLESS SPECIFIED
DIMENSIONS IN INCHES
TOLERANCES ON:
2 PLC DEC ± -
3 PLC DEC ± -
ANGLES ± -

MATERIAL
COPPER
ASTM-B-75
ANNEALED

FINISH
SEE TABLE

DR 1/16/89 P FORTNEY
CHK 6/20/89 MS FEHER
APPD 6/20/89 WJ VOCKROTH
APPD 6/20/89 R ADAMS
PRODUCT SPEC -
APPLICATION SPEC -
WEIGHT .305 LB.

AMP			AMP INCORPORATED Harrisburg, Pa. 17105		
NAME WIRE SPLICE, PARALLEL, AMPOWER, WIRE SIZE: 1000 MCM					
SIZE A	FSCM NO 00779	DRAWING NO 324456			
SCALE 1:1				SHEET 1 OF 1	

