

4

3

2

1

THIS DRAWING IS UNPUBLISHED. RELEASED FOR PUBLICATION .19
 © COPYRIGHT 19 BY AMP INCORPORATED. ALL RIGHTS RESERVED.

LOC	DIST	REVISIONS			
P	LTR	DESCRIPTION	DATE	DWN	APVD
G	86	F	REV PER 063A-0637-01	03OCT02	JR MS

- ① TIN PLATE 0.00381[.000150] MIN THK PER ASTM B 545
- ② CLEANED, UNPLATED
- ③ PREPRODUCTION - FASR REQ

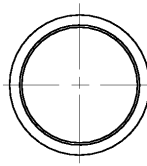
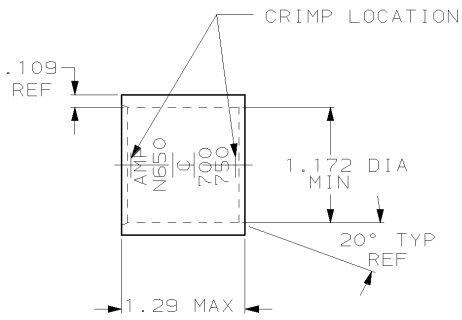

△-	△1-324453-0
△-	324453
FINISH	AMP PART NUMBER

THIS DRAWING IS A CONTROLLED DOCUMENT FOR AMP INCORPORATED. IT IS SUBJECT TO CHANGE AND THE CONTROLLING ENGINEERING ORGANIZATION SHOULD BE CONTACTED FOR THE LATEST REVISION.		DWN DK SCHRUM 01.JUL.96	AMP Incorporated Harrisburg, PA 17105-3608	
DIMENSIONS: mm (INCHES)		CHK WJ VOCKROTH 02.JUL.96	NAME WIRE SPLICE, PARALLEL, AMPOWER™ WIRE SIZE: 700 MCM	
TOLERANCES UNLESS OTHERWISE SPECIFIED:		APVD JL MECKLEY 02.JUL.96	DRAWING NO A3 00779 C-324453	
0 PLC ± 1 PLC ± 2 PLC ± 3 PLC ± 4 PLC ± ANGLES ±		PRODUCT SPEC APPLICATION SPEC	SIZE A3	CAGE CODE 00779
MATERIAL COPPER PER ASTM B-75 ANNEALED	FINISH SEE TABLE	WEIGHT .181 lbs	DRAWING NO C-324453	
CUSTOMER DRAWING			SCALE 2:1	SHEET 1 OF 1

AMP 1470-19 REV 09MAY94

01-JUL-96 11:30:51 amp26463 /Files/dept1123/dwg1123/u.ampower/u.splIce