

THIS DRAWING IS UNPUBLISHED. RELEASED FOR PUBLICATION .19
 © COPYRIGHT 19 BY AMP INCORPORATED. ALL INTERNATIONAL RIGHTS RESERVED.

LOC	DIST	P	F	ZONE	LTR	DESCRIPTION	DATE	APPRO
6	14					E REV PER 063A-0123-02	07MAR02	MS

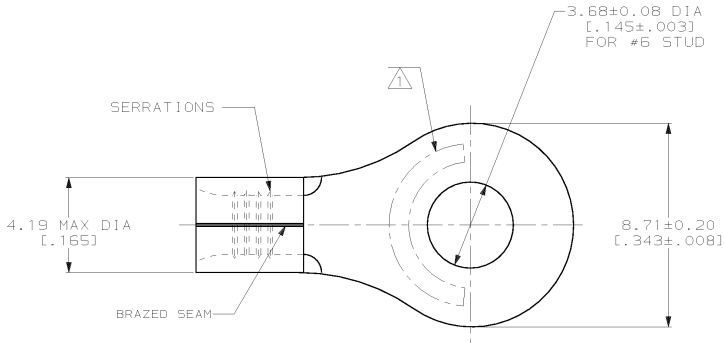

AMP WIRE RANGE	UL E13288 Listed
16-14 AWG SOLID OR STRANDED	16-14 AWG SOLID OR STRANDED
LR7189 Certified	MILITARY P/N AND CLASS
16-14 AWG SOLID OR STRANDED	NOT APPLICABLE

- ⚠ STAMP AMP 16-14* APPROX AS SHOWN
- ⚠ 0.00254 [.000100] MIN TIN PER ASTM B-545.
- ⚠ CLEANED, UNPLATED

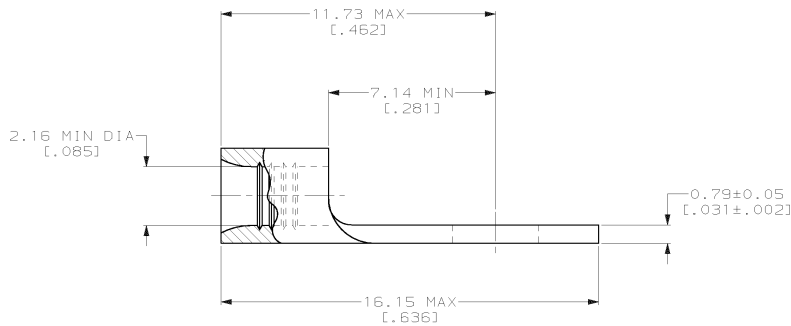

FINISH	QUANTITY	PACKAGING TYPE	PART NO
3	-	LOOSE PIECE	34121-1
2	100	LOOSE PIECE, BOX	8-34121-1
	5000	ON TAPE	2-34121-1
	---	LOOSE PIECE	34121

AMP INCORPORATED CUSTOMER SERVICE SYSTEMS		MAX RECOMMENDED OPERATING TEMPERATURE: 170°C MAX	DO NOT SCALE PRINT. UNLESS SPECIFIED DIMENSIONS IN mm (INCHES) TOLERANCES ON: 2 PLC DEC # - 3 PLC DEC # - ANGLES # -	DR 3-11-93 TA BRINKMAN CHK 3-11-93 DA PATTERSON APPD 3-11-93 DE MILLER APPD 3-11-93 JL MECKLEY	AMP AMP Incorporated Harrisburg, PA 17105-3608	
FOR ADDITIONAL PRODUCT INFORMATION OR COPIES OF DRAWINGS AND TECHNICAL DOCUMENTS	PRODUCT INFORMATION CENTER 1-800-522-6752	VOLTAGE RATING: NOT APPLICABLE	MATERIAL COPPER PER ASTM B-152 ANNEALED	NAME	TERMINAL, RING TONGUE, SOLISTRAND	
FOR APPLICATION TOOLING INFORMATION	TOOLING ASSISTANCE CENTER 1-800-722-1111	WIRE CROSS SECTIONAL AREA RANGE: 1.04-2.62mm² [2,050-5,180] CIR MILS SOLID OR STRANDED	FINISH - SEE TABLE	APPLICATION SPEC -	SIZE C 00779	DRAWING NO C-34121
FOR ORDER ENTRY	1-800-526-5142	THIS DRAWING IS A CONTROLLED DOCUMENT FOR AMP INCORPORATED. IT IS SUBJECT TO CHANGE AND THE CONTROLLING ENGINEERING ORGANIZATION SHOULD BE CONTACTED FOR THE LATEST REVISION.	WEIGHT -	SCALE 8:1	SHEET 1 OF 1	

AMP 1471-B REV 3-92
 12-FEB-99 13:59:00 amp10398 /home/ssrv027a/dsk01/dept1132/amp10398/edmod

CUSTOMER DRAWING

34121

A