

4

3

2

1

THIS DRAWING IS UNPUBLISHED. RELEASED FOR PUBLICATION
 © COPYRIGHT - BY TYCO ELECTRONICS CORPORATION. ALL RIGHTS RESERVED.

LOC	DIST	REVISIONS					
		P	LTR	DESCRIPTION	DATE	DWN	APVD
G	14	J		REV PER 0G3A-0640-04	16AUG04	JR	TM

AMP WIRE RANGE	Listed FILE E13288	LR7189 Certified
22-16 AWG SOLID OR STRANDED	22-16 AWG SOLID OR STRANDED	22-16 AWG SOLID OR STRANDED

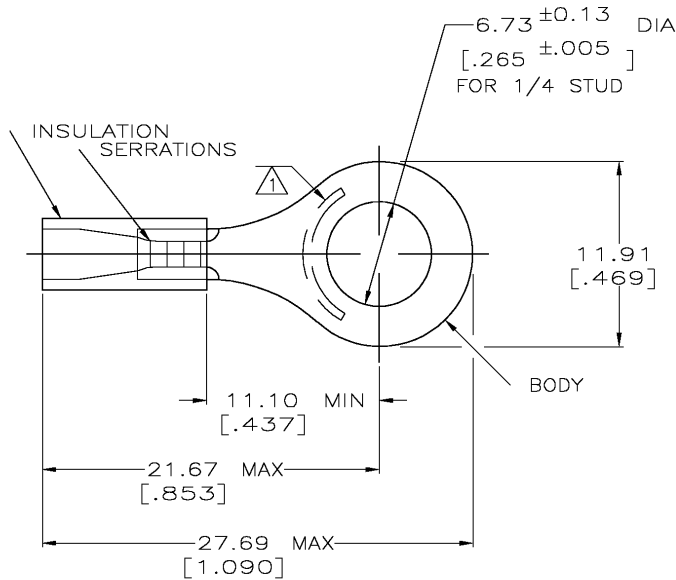

- 1 STAMP AMP 22-18* APPROX AS SHOWN
22-16 TERMINALS ARE STAMPED 22-18 IN
ACCORDANCE WITH MILITARY SPEC MIL-T-7928
COMMERCIAL WIRE RANGE IS 22-16
- 2 WIRE INSULATION DIA: 2.03-3.18 [.080-.125]
- 3 TONGUE MATERIAL THK: 0.79 ±0.05 [.031 ±.002]
- 4 MATERIAL: BODY - CU PER ASTM B152
SLEEVE - PVC, COLOR - RED

100	LOOSE PC,BOX	8-32953-1
5000	ON TAPE, REEL	2-32953-1
1000	LOOSE PIECE	32953
QTY	PACKAGE TYPE	PART NO.

AMP INCORPORATED CUSTOMER SERVICE SYSTEMS		MAX RECOMMENDED OPERATING TEMPERATURE: 105°C [221°F]	THIS DRAWING IS A CONTROLLED DOCUMENT.		DWN 08/06/92 CHK DK SCHRUM RE 11/10/92 APVD RE HERSEY M BARNABA 11/10/92	Tyco Electronics Corporation Harrisburg, Pa 17105-3608
FOR ADDITIONAL PRODUCT INFORMATION OR COPIES OF DRAWINGS AND TECHNICAL DOCUMENTS PRODUCT INFORMATION CENTER 1-800-522-6752	FOR APPLICATION TOOLING ASSISTANCE CENTER TOOLING INFORMATION 1-800-722-1111	VOLTAGE RATING: 600V MAX (1000V FIXTURE OR SIGN)	DIMENSIONS: MM [INCHES]	TOLERANCES UNLESS OTHERWISE SPECIFIED: 0 PLC ± - 1 PLC ± - 2 PLC ± 0.20 [008] 3 PLC ± - 4 PLC ± - ANGLES ± -	PRODUCT SPEC UL 486A	NAME TERMINAL, RING TONGUE, PLASTI-GRIP, WIRE SIZE, 22-16 AWG
FOR ORDER ENTRY 1-800-526-5142	THIS DRAWING IS A CONTROLLED DOCUMENT FOR AMP INCORPORATED. IT IS SUBJECT TO CHANGE AND THE CONTROLLING ENGINEERING ORGANIZATION SHOULD BE CONTACTED FOR THE LATEST REVISION.	CIRCULAR MIL AREA: 0.26-1.85mm² [509-3260] SOLID OR STRANDED	MATERIAL 	FINISH TIN PER ASTM B545	APPLICATION SPEC -	SIZE CAGE CODE DRAWING NO RESTRICTED TO A3 00779 C-32953 -
AMP 1470-19 REV 31MAR2000					WEIGHT -	CUSTOMER DRAWING SCALE 4:1 SHEET 1 OF 1 REV J