

4

3

2

1

THIS DRAWING IS UNPUBLISHED. RELEASED FOR PUBLICATION. ALL RIGHTS RESERVED.

LOC	DIST	REV	DESCRIPTION	DATE	BY	APP'D
G	14	F2	REVISED PER ECO-11-012152	15JUN11	HMR	DR

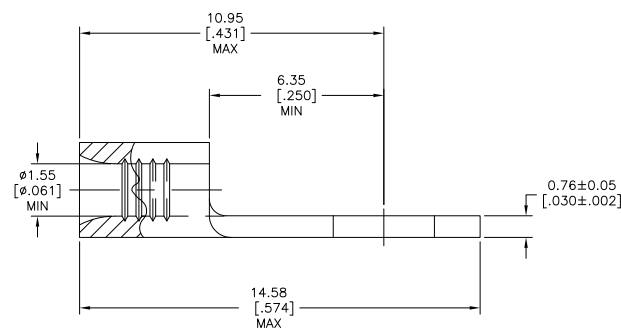
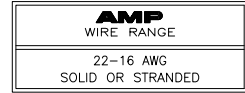
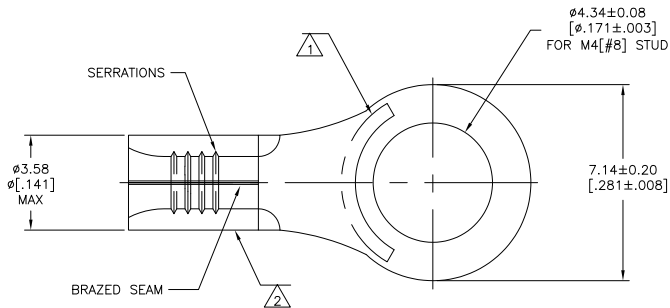

- 1 STAMP AMP 22-18 APPROX AS SHOWN 22-16 TERMINALS ARE STAMPED 22-18 IN ACCORDANCE WITH MILITARY SPECIFICATION SAE AS7928 COMMERCIAL WIRE RANGE IS 22-16
- 2 WIRE BARREL COLOR CODED ORANGE TO DENOTE NICKEL MATERIAL
- 3 TAPE MOUNTED PART NUMBER PRODUCED ONLY BY FOREIGN SUBSIDIARIES OF AMP INC
- 4 OBSOLETE PART.
- 5 GOLD PLATE 0.00127[.000050] MIN EXT THK PER ASTM B488, TYPE1, CODE C OVER NICKEL FLASH PER SAE AMS QQ-N-290 OVER WOODS NICKEL FLASH PER ASTM B558.
- 6 PRELIMINARY PART NUMBER.

### AMP INCORPORATED CUSTOMER SERVICE SYSTEMS

MAX RECOMMENDED OPERATING TEMPERATURE:	SEE TABLE
VOLTAGE RATING:	NOT APPLICABLE
WIRE CROSS SECTIONAL AREA RANGE:	0.26-1.65mm <sup>2</sup> [509-3,260] CIR MILS SOLID OR STRANDED

FOR ADDITIONAL PRODUCT INFORMATION OR COPIES OF DRAWINGS AND TECHNICAL DOCUMENTS	PRODUCT INFORMATION CENTER 1-800-522-6752
FOR APPLICATION TOOLING INFORMATION	TOOLING ASSISTANCE CENTER 1-800-722-1111
FOR ORDER ENTRY	1-800-526-5142

649°C [1200°F]	100	LOOSE PIECE, BOX	8-321890-1	
649°C [1200°F]	---	ON TAPE	32-321890-2	
260°C [500°F]	1000	LOOSE PIECE	321890-1	
649°C [1200°F]	1000	LOOSE PIECE	321890	
FINISH	MAX OPERATING TEMP.	QTY	PACKAGING TYPE	PART NO

THIS DRAWING IS A CONTROLLED DOCUMENT.		DATE: 4-15-93	TE Connectivity
DRAWN BY: TA BRINKMAN		DATE: 4-15-93	
CHECKED BY: DA PATTERSON		DATE: 4-15-93	TERMINAL, RING TONGUE, HIGH TEMPERATURE, STRATO-THERM
DESIGNED BY: DE MILLER		DATE: 4-15-93	
DIMENSIONS: mm [INCHES]		APPLICATION SPEC:	RESTRICTED TO: ---
TOLERANCES UNLESS OTHERWISE SPECIFIED:		WEIGHT: ---	SIZE: A2
0 PLG ± .01		FINISH: SEE TABLE	CAGE CODE: 00779
1 PLG ± .01		MATERIAL: NICKEL ASTM B-142 ANNEALED	DRAWING NO: 321890
2 PLG ± .01			CUSTOMER DRAWING
3 PLG ± .01			SCALE: 10:1
4 PLG ± .01			SHEET: 1 of 1
5 PLG ± .01			REV: F2

1471-9 (3/11)

321890

A