

4

3

2

1

THIS DRAWING IS UNPUBLISHED. RELEASED FOR PUBLICATION
 © COPYRIGHT - By - ALL RIGHTS RESERVED.

| LOC | DIST | REVISIONS | | | |
|-----|------|-------------|---------------------------|---------|--------|
| P | LTR | DESCRIPTION | DATE | DWN | APVD |
| G | 14 | H2 | REVISED PER ECO-11-004820 | 11MAR11 | RK HMR |

| | | |
|--------------------------------|--------------------------------|--------------------------------|
| AMP WIRE RANGE | Listed FILE E13288 | LR7189 Certified |
| 22-16 AWG SOLID OR STRANDED | 22-16 AWG SOLID OR STRANDED | 22-16 AWG SOLID OR STRANDED |

- 1 STAMP AMP 22-18* APPROX AS SHOWN
22-16 TERMINALS ARE STAMPED 22-18 IN
ACCORDANCE WITH MILITARY SPEC MIL-T-7928
COMMERCIAL WIRE RANGE IS 22-16
- 2 WIRE INSULATION DIA: 2.03-3.18 [.080-.125]
- 3 TONGUE MATERIAL THK: 0.79±0.05 [.031±.002]
- 4 BODY : TIN PLATE PER
ASTM B545,
- 5 BODY - CU PER ASTM B152
SLEEVE - NYLON, COLOR - RED
- 6 APPLIES FROM EDGE OF METAL WIRE BARREL
TO CENTER OF STUD HOLE.

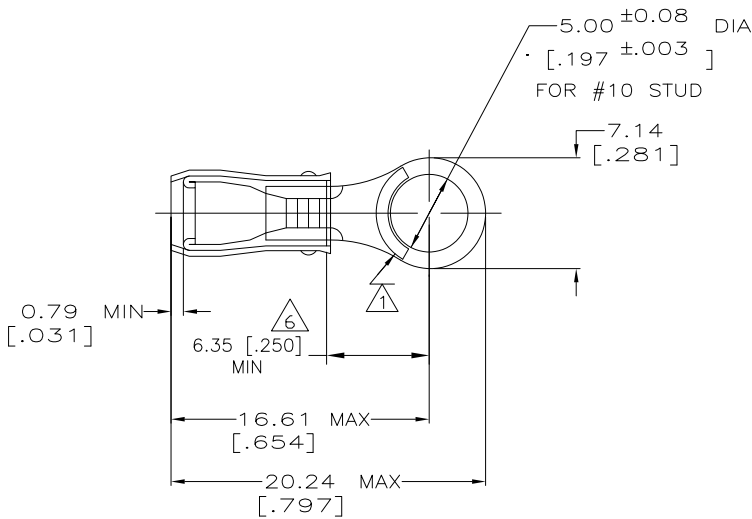

| | | |
|------|------------------|------------|
| 100 | LOOSE PIECE, BOX | 8-320552-1 |
| 5000 | ON TAPE, REEL | 2-320552-1 |
| - | LOOSE PIECE | 320552 |
| QTY | PACKAGE | PART NO |

| | | | | | | | |
|--|--|---|--|--|---|---|--------------------|
| AMP INCORPORATED CUSTOMER SERVICE SYSTEMS | | MAX RECOMMENDED OPERATING TEMPERATURE: 105°C MAX | THIS DRAWING IS A CONTROLLED DOCUMENT. | | DWN DK SCHRUM 02/11/93 CHK RE HERSEY 4/28/93 | TE Connectivity | |
| FOR ADDITIONAL PRODUCT INFORMATION OR COPIES OF DRAWINGS AND TECHNICAL DOCUMENTS | PRODUCT INFORMATION CENTER 1-800-522-6752 | VOLTAGE RATING: 300 V MAX | DIMENSIONS: MM [INCHES] | TOLERANCES UNLESS OTHERWISE SPECIFIED: | APVD M BARNABA 4/28/93 | NAME TERMINAL, RING TONGUE, PIDG, 22-16 AWG | |
| FOR APPLICATION TOOLING INFORMATION | TOOLING ASSISTANCE CENTER 1-800-722-1111 | CIRCULAR MIL AREA: 0.26-1.65mm² [509-3,260] SOLID OR STRANDED | | 0 PLC ± - 1 PLC ± - 2 PLC ± 0.20[.008] 3 PLC ± - 4 PLC ± - ANGLES ± - | PRODUCT SPEC UL 486A | SIZE A3 | CAGE CODE 00779 |
| FOR ORDER ENTRY | 1-800-526-5142 | THIS DRAWING IS A CONTROLLED DOCUMENT FOR AMP INCORPORATED. IT IS SUBJECT TO CHANGE AND THE CONTROLLING ENGINEERING ORGANIZATION SHOULD BE CONTACTED FOR THE LATEST REVISION. | MATERIAL - 5 | FINISH - 4 | APPLICATION SPEC NOT AVAILABLE | DRAWING NO C-320552 | RESTRICTED TO - |
| | | | | | WEIGHT - | SCALE 4:1 | SHEET 1 OF 1 |
| | | | | | CUSTOMER DRAWING | REV H2 | |