

4

3

2

1

THIS DRAWING IS UNPUBLISHED. RELEASED FOR PUBLICATION
 © COPYRIGHT 19 BY AMP INCORPORATED. ALL RIGHTS RESERVED.

LOC		DIST		REVISIONS			
P	LTR	DESCRIPTION		DATE	DWN	APVD	
G	14	G	REV / 0720-0660-95	07JUL95	ME	SB	

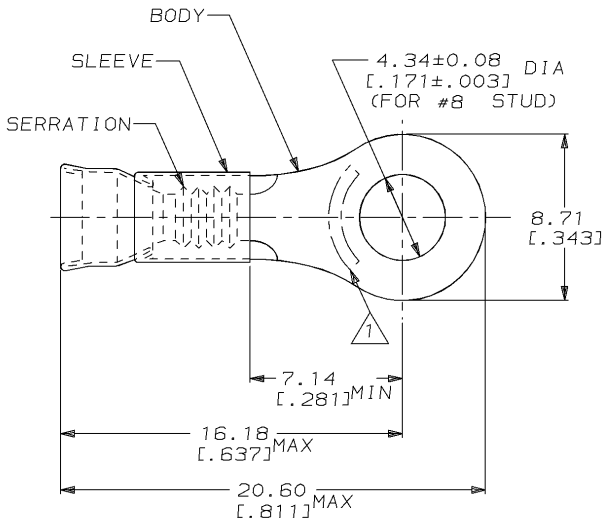

- 1. STAMP AMP 16-14* APPROX AS SHOWN
- 2. WIRE INSUL DIA, 3.05-4.32 [0.120-.170]
- 3. TONGUE MATL THK, 0.79±0.05 [0.031±.002]
- 4. NICKEL PLATE PER QQ-N-290
- 5. GOLD PLATE PER MIL-G-45204 OVER NICKEL PLATE PER QQ-N-290

4	1000	LOOSE PIECE	322274-1
	1000	LOOSE PIECE	322374
	QTY	PACKAGE TYPE	PART NO

AMP INCORPORATED CUSTOMER SERVICE SYSTEM		MAX RECOMMENDED OPERATING TEMPERATURE: 343°C [650°F]	THIS DRAWING IS A CONTROLLED DOCUMENT FOR AMP INCORPORATED. IT IS SUBJECT TO CHANGE AND THE CONTROLLING ENGINEERING ORGANIZATION SHOULD BE CONTACTED FOR THE LATEST REVISION.		DWN L OLMEDA 100CT94	AMP AMP Incorporated Harrisburg, PA 17105-3608
FOR ADDITIONAL PRODUCT INFORMATION OR COPIES OF DRAWINGS AND TECHNICAL DOCUMENTS	PRODUCT INFORMATION CENTER 1-800-522-6752	VOLTAGE RATING: -	DIMENSIONS: mm [in]	TOLERANCES UNLESS OTHERWISE SPECIFIED: 0 PLC ±- 1 PLC ±- 2 PLC ±0.20 (0.008) 3 PLC ±- 4 PLC ±- ANGLES ±-	CHK M ELLIS 100CT94	
FOR APPLICATION TOOLING INFORMATION	TOOLING ASSISTANCE CENTER 1-800-722-1111	CIRCULAR MIL AREA: 1.04mm² - 2.62mm² [2050-5180]	MATERIAL BODY, CU PER ASTM B152 SLEEVE, NI SIL PER ASTM B122	FINISH SEE NOTES 4 & 5	PRODUCT SPEC	TERMINAL, RING TONGUE, STRATO-THERM™, DIAMOND GRIP™ WIRE SIZE, 16-14 AWG
FOR ORDER ENTRY	1-800-526-5142	STRANDED WIRE			APPLICATION SPEC	SIZE A3
AMP 1470-19 REV 09MAY94					WEIGHT -	CAGE CODE 00779
					CUSTOMER DRAWING	DRAWING NO C-322374
						SCALE 6:1
						SHEET 1 OF 1
						REV 6