

4

3

2

1

THIS DRAWING IS UNPUBLISHED. RELEASED FOR PUBLICATION
 © COPYRIGHT BY TYCO ELECTRONICS CORPORATION. ALL RIGHTS RESERVED.

LOC	DIST	REVISIONS			
P	LTR	DESCRIPTION	DATE	DWN	APVD
G	14	E	REDRAWN PER 0G3A-0709-03	07NOV03	JR MS

- 1 STAMP "AMP 300-350 MCM"
APPROX AS SHOWN ON BOTTOM
- 2 COPPER, .136±.004 THK, PER
ASTM B-152, ANNEALED
- 3 TIN PLATE PER ASTM B-545

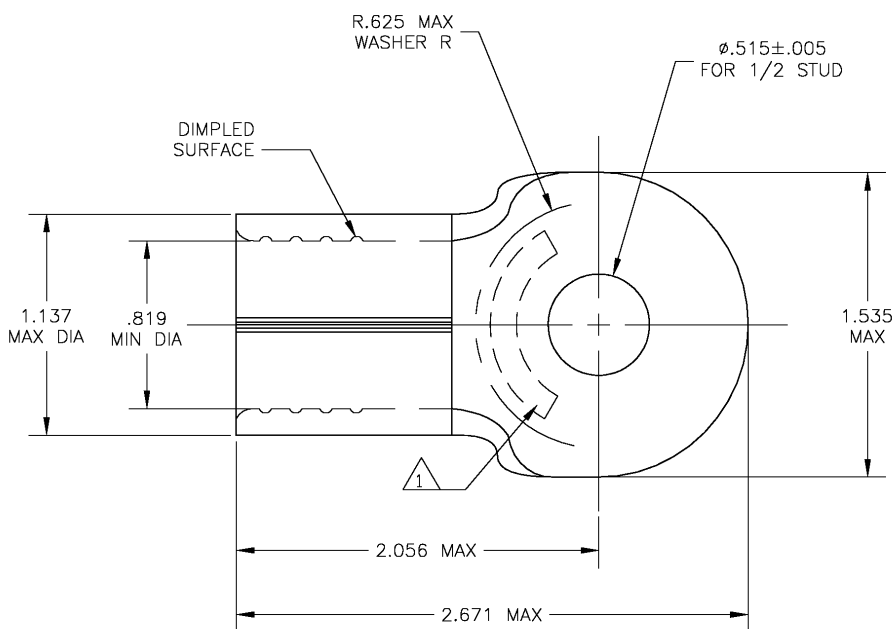

1-322255-4
 PART NO

THIS DRAWING IS A CONTROLLED DOCUMENT.		DWN jr ruth 07NOV03	Tyco Electronics Corporation Harrisburg, PA 17105	
DIMENSIONS: INCHES		CHK MJ SPICER 07NOV03	NAME	
TOLERANCES UNLESS OTHERWISE SPECIFIED:		APVD MJ SPICER 07NOV03	WIRE TERMINAL SOLISTRAND, RING TONGUE, WIRE SIZE: 300-350 MCM	
0 PLC ± -		PRODUCT SPEC	SIZE	CAGE CODE
1 PLC ± -		APPLICATION SPEC	A3	00779
2 PLC ± -		WEIGHT	DRAWING NO	RESTRICTED TO
3 PLC ± .008			C-322255	
4 PLC ± -				
ANGLES ± 5°				
MATERIAL	FINISH	CUSTOMER DRAWING		
2	3	SCALE	2:1	SHEET 1 OF 1 REV E

AMP 1470-19 REV 31MAR2000

C:\ENGapps\TECacad\4.0\bin\