

4

3

2

1

THIS DRAWING IS UNPUBLISHED. RELEASED FOR PUBLICATION
 © COPYRIGHT - BY TYCO ELECTRONICS CORPORATION. ALL RIGHTS RESERVED.

LOC	DIST	REVISIONS			
P	LTR	DESCRIPTION	DATE	DWN	APVD
	D1	REV PER ECR 06-014599	16JUN06	JR	MS

AMP WIRE RANGE	Listed FILE E13288	LR7189 Certified
12-10 AWG SOLID OR STRANDED	12-10 AWG P/N 31772 ONLY	12-10 AWG P/N 31772 ONLY

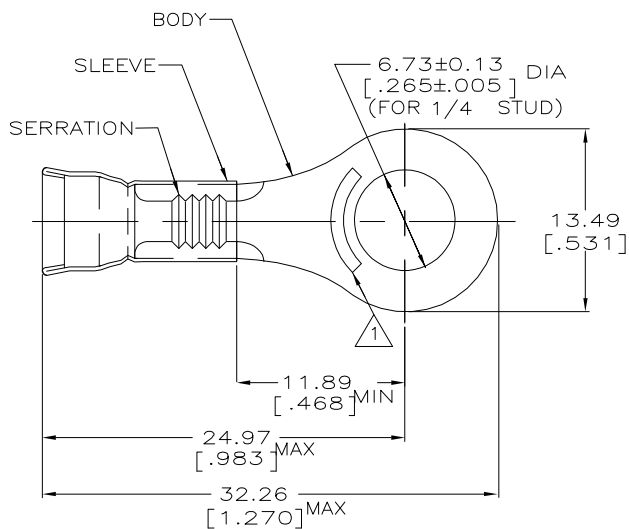

- ① STAMP AMP 12-10* LOCATE APPROX AS SHOWN
- 2. WIRE INSUL DIA, 3.81-5.84 [.150-.230]
- 3. TONGUE MATL THK, 1.02±0.05 [.040±.002]
- ④ TIN PLATE PER ASTM B-545
- ⑤ GOLD PLATE PER MIL-G-45204 OVER NICKEL PLATE PER QQ-N-290
- ⑥ MATERIAL: BODY - CU PER ASTM B152
SLEEVE - CU PER ASTM B152

⑤	-	LOOSE PIECE	2-31772-2
④	500	LOOSE PIECE	31772
FINISH	QTY	PACKAGE TYPE	PART NO

AMP INCORPORATED CUSTOMER SERVICE SYSTEMS		MAX RECOMMENDED OPERATING TEMPERATURE: 170°C [338°F]	THIS DRAWING IS A CONTROLLED DOCUMENT.		DWN L OLMEDA 23JAN95	tyco Electronics Tyco Electronics Corporation Harrisburg, Pa 17105-3608	
FOR ADDITIONAL PRODUCT INFORMATION OR COPIES OF DRAWINGS AND TECHNICAL DOCUMENTS	PRODUCT INFORMATION CENTER 1-800-522-6752	VOLTAGE RATING: -	DIMENSIONS: mm (inches)	TOLERANCES UNLESS OTHERWISE SPECIFIED: 0 PLC ± - 1 PLC ± - 2 PLC ± 0.20 [008] 3 PLC ± - 4 PLC ± - ANGLES ± -	CHK M ELLIS 23JAN95	NAME S BORTNER	
FOR APPLICATION	TOOLING ASSISTANCE CENTER 1-800-722-1111	CIRCULAR MIL AREA: 2.62-6.64mm² [5,180-13,100] SOLID OR STRANDED		FINISH SEE TABLE	APVD S BORTNER 23JAN95	PRODUCT SPEC UL486A	
TOOLING INFORMATION	1-800-722-1111	THIS DRAWING IS A CONTROLLED DOCUMENT FOR AMP INCORPORATED. IT IS SUBJECT TO CHANGE AND THE CONTROLLING ENGINEERING ORGANIZATION SHOULD BE CONTACTED FOR THE LATEST REVISION.	MATERIAL ⑥	WEIGHT -	APPLICATION SPEC -	SIZE A3	CAGE CODE 00779
FOR ORDER ENTRY	1-800-526-5142				RESTRICTED TO -	DRAWING NO C-31772	REV D1
AMP 1470-19 REV 31MAR2000					CUSTOMER DRAWING		SCALE 4:1 SHEET 1 OF 1