

4

3

2

1

THIS DRAWING IS UNPUBLISHED. RELEASED FOR PUBLICATION. ALL RIGHTS RESERVED.

LOC	DIST	REVISIONS		
P	LR	DESCRIPTION	DATE	BY
G	14			
	W2	REVISED PER ECO-11-004587	11MAR11	RK HMR

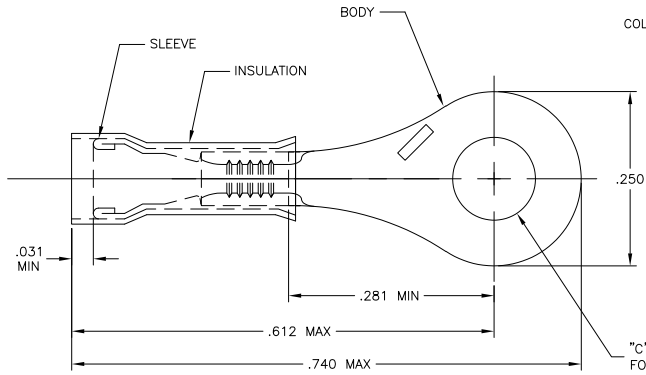

STYLE 1

COLOR CODE STRIPE
SEE TABLE
3 EQUALLY
SPACED STRIPES

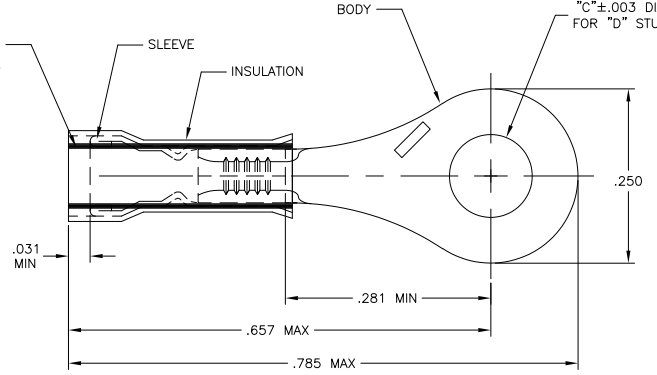

STYLE 2
INSULATION RESTRICTING

- 1 STAMP "AMP", APPROX AS SHOWN
- 2 WIRE INSULATION DIA: SEE TABLE
- 3 TONGUE MATERIAL THK: .018±.002
- 4 BODY & SLEEVE: CU PER ASTM B152
INSULATION: NYLON PER ASTM D4066, COLOR - YELLOW
- 5 BODY: TIN PLATE .000100 MIN EXT THK
PER ASTM B545
- 6 SLEEVE: TIN PLATE .000100 MIN THK PER
ASTM B545
- 7 SLEEVE: NICKEL PLATE PER QQ-N-290
- 8 APPLIES FROM EDGE OF METAL WIRE BARREL
TO CENTER OF STUD HOLE.
- 9 MEETS MS25036-145, CLASS 2
- 10 300 VOLTS MAX

QTY	PACKAGE TYPE	STUD SIZE "D"	DIM "C"	WIRE INSUL DIA	WIRE SIZE	COLOR CODE	STYLE	BODY / SLEEVE FINISH	MATERIAL	PART NO
100	LOOSE PIECE, BOX	#6	.145	.050-.082	26-22	--	A			8-326875-1
OBSOLETE	100	LOOSE PIECE, SM. BOX	#6	.145	.050-.082	26-22	--	A		3-326875-9
OBSOLETE	1000	LOOSE PIECE, LG. BOX	#6	.145	.050-.082	26-22	--	A		2-326875-9
OBSOLETE	5000	2-326875-4 ON TAPE, REEL	#6	.145	.031-.055	24	BLUE	B		2-326875-8
OBSOLETE	5000	2-326875-3 ON TAPE, REEL	#10	.197	.026-.055	26	BLACK	B		2-326875-7
OBSOLETE	5000	2-326875-2 ON TAPE, REEL	#6	.145	.026-.055	26	BLACK	B		2-326875-6
500	LOOSE PIECE	#10	.197	.031-.055	24	BLUE	B			2-326875-5
500	LOOSE PIECE	#6	.145	.031-.055	24	BLUE	B			2-326875-4
OBSOLETE	500	LOOSE PIECE	#10	.197	.026-.055	26	BLACK	B		2-326875-3
OBSOLETE	500	LOOSE PIECE	#6	.145	.026-.055	26	BLACK	B		2-326875-2
4000	326875-1 ON TAPE, REEL	#6	.145	.050-.082	26-22	--	A			2-326875-1
500	LOOSE PIECE	#6	.145	.050-.082	26-22	--	A			326875

THIS DRAWING IS A CONTROLLED DOCUMENT.

INCHES: 0 PLG ± .008, 1 PLG ± .008, 2 PLG ± .008, 3 PLG ± .008, 4 PLG ± .008, 5 PLG ± .008, 6 PLG ± .008, 7 PLG ± .008, 8 PLG ± .008, 9 PLG ± .008, 10 PLG ± .008

MATERIAL: SEE TABLE. FINISH: SEE TABLE.

APPROVED: JR. RUTH, 14ANN10. DSK. TOM MICHELLOTTI, 14ANN10. NAME: MIKE PERCHERKE, 14ANN10. PRODUCT SPEC: APPLICATION SPEC: WEIGHT: CUSTOMER DRAWING.

TE Connectivity. TERMINAL, NYLON - PIDG - RING TONGUE. WIRE SIZE: 26-22. SIZE: A2. CASE CODE: 00779. DRAWING NO: C=326875. SCALE: 10:1. SHEET: 1 of 1. REV: W2.