

4

3

2

1

THIS DRAWING IS UNPUBLISHED. RELEASED FOR PUBLICATION  
 BY AMP INCORPORATED. ALL RIGHTS RESERVED.

LOC	DIST	REVISIONS			
P	LTR	DESCRIPTION	DATE	DWN	APVD
G	14	D	REV / 0L20-0197-97	21AUG97	ME SB

AMP WIRE RANGE	E13288	LR7189 Certified
12-10 AWG SOLID OR STRANDED	12-10 AWG SOLID OR STRANDED	12-10 AWG SOLID OR STRANDED

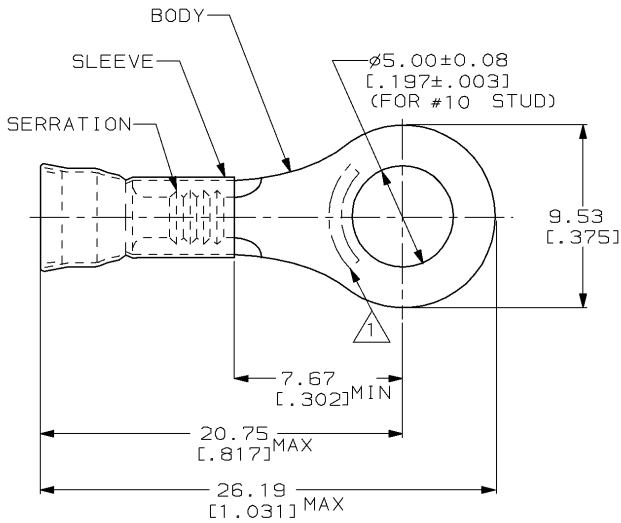

- 1 STAMP AMP 12-10\* LOCATE APPROX AS SHOWN
- 2 WIRE INSUL DIA, 3.81-5.84 [.150-.230]
- 3 TONGUE MATL THK, 0.99±0.05 [.039±.002]

2500	ON TAPE, REEL	2-31771-1
500	LOOSE PIECE	31771
QTY	PACKAGE TYPE	PART NO

AMP INCORPORATED CUSTOMER SERVICE SYSTEM		MAX RECOMMENDED OPERATING TEMPERATURE: 170°C [338°F]	THIS DRAWING IS A CONTROLLED DOCUMENT FOR AMP INCORPORATED. IT IS SUBJECT TO CHANGE AND THE CONTROLLING ENGINEERING ORGANIZATION SHOULD BE CONTACTED FOR THE LATEST REVISION.		DWN L OLMEDA 23JAN95	AMP Incorporated Harrisburg, PA 17105-3608
FOR ADDITIONAL PRODUCT INFORMATION OR COPIES OF DRAWINGS AND TECHNICAL DOCUMENTS	PRODUCT INFORMATION CENTER 1-800-522-6752	VOLTAGE RATING: -	DIMENSIONS: mm [in]	TOLERANCES UNLESS OTHERWISE SPECIFIED: 0 PLC ±- 1 PLC ±- 2 PLC ±0.20 (.008) 3 PLC ±- 4 PLC ±- ANGLES ±-	CHK M ELLIS 23JAN95	
FOR APPLICATION TOOLING INFORMATION	TOOLING ASSISTANCE CENTER 1-800-722-1111	CIRCULAR MIL AREA: 2.62mm²-6.64mm² [S180-13100]	MATERIAL BODY, CU, SLV, CU PER ASTM B152	FINISH TIN PLATE PER ASTM B 545	APVD S BORTNER 23JAN95	PRODUCT SPEC UL486A
FOR ORDER ENTRY	1-800-526-5142				APPLICATION SPEC	WIRE SIZE, 12-10 AWG
AMP 1470-19 REV 09HAY94					WEIGHT	SIZE A3
					CUSTOMER DRAWING	CAGE CODE 00779
						DRAWING NO C-31771
						SCALE 6:1
						SHEET 1 OF 1
						REV D