

DRAWING MADE IN AMERICAN PROJECTION

© 1967 BY AMP INCORPORATED. ALL RIGHTS RESERVED. AMP PRODUCTS COVERED BY PATENTS AND/OR PATENTS PENDING.

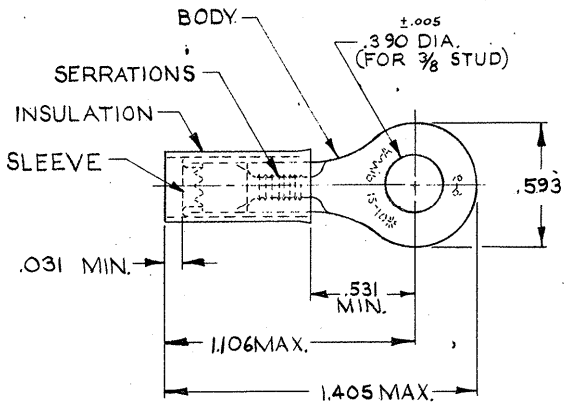

FOR .102 TO .214 WIRE INSULATION DIA.
TONGUE MATERIAL THK. = .040 ±.002

REVISIONS				
ZONE	LTR	DESCRIPTION	DATE	APPROVED
B		REDRAWN & REV P-6077	7-30-69	FCY
C		REVISED PC-5579	10-8-70	JML
D		REVISED PC-5578		
E		REV 10610-0098-98	2-4-79	SL
E1		REV DGR CLR 05-013140	10/20/05	VR/TM

1	WIRE TERMINAL	50848	BODY: COPPER (ASTM B152) NICKEL PLATE (QQ-N-290) .0003 AVG. EXT. THK.
			SLEEVE: COPPER (ASTM B152) NICKEL PL (QQ-N-290).00003 AVG. EXT. THK.
			INSULATION: TEFLON (ASTM D3295) COLOR: BLACK
QTY	DESCRIPTION	PART NO.	MATERIAL & FINISH
UNLESS OTHERWISE SPECIFIED DIMENSIONS ARE IN INCHES TOLERANCES ON: DECIMALS ± .008 ANGLES ± 5°	CONTRACT NO. 11	DR. J. J. Faut 7-29-69	AMP AMP INCORPORATED HARRISBURG, PENNSYLVANIA
MATERIAL	CHK. J. J. Faut 7-30-69	APPD. J. J. Faut 8-6-69	NAME WIRE TERMINAL PIDG™ STRATO-THERM - RING TONGUE WIRE SIZE: 12-10
SEE TABLE	REL. M. Ensminger 8-6-69	DSGN APPD.	SIZE B CODE IDENT NO. 00779 NUMBER 50848
	OTHER APPD.	SCALE NTS	SHEET 1 OF 1