

4

3

2

1

THIS DRAWING IS UNPUBLISHED. RELEASED FOR PUBLICATION
 © COPYRIGHT - By - ALL RIGHTS RESERVED.

| LOC | DIST | REVISIONS | | | |
|-----|------|-------------|---------------------------|---------|--------|
| P | LTR | DESCRIPTION | DATE | DWN | APVD |
| G | 02 | E2 | REVISED PER ECO-11-004917 | 11MAR11 | RK HMR |

| | | |
|--------------------------------|--------------------------------|--------------------------------|
| AMP WIRE RANGE | Listed FILE E13288 | LR7189 Certified |
| 16-14 AWG SOLID OR STRANDED | 16-14 AWG SOLID OR STRANDED | 16-14 AWG SOLID OR STRANDED |

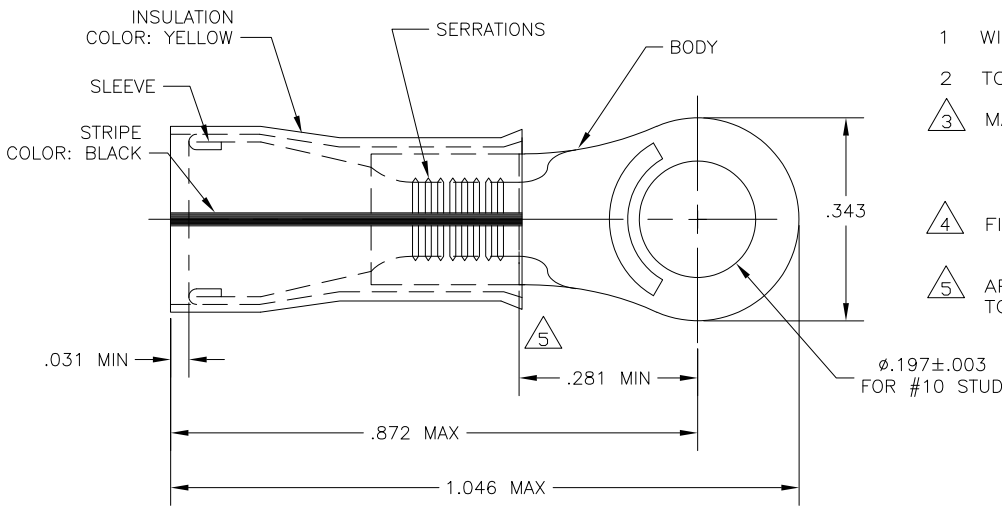

- 1 WIRE INSUL DIA .150-.230
- 2 TONGUE MATERIAL THK .048±.002
- 3 MATERIAL: BODY - CU PER ASTM B152
SLEEVE - CU PER ASTM B152
INSULATION - NYLON (MIL-M-20693)
TYPE 1
- 4 FINISH: BODY & SLEEVE: TIN PER ASTM B-545
INSULATION - COLOR: YELLOW
- 5 APPLIES FROM EDGE OF METAL WIRE BARREL
TO THE CENTER OF STUD HOLE.

| | | |
|------|------------------|------------|
| 100 | LOOSE PIECE, BOX | 8-320630-1 |
| 2500 | ON TAPE | 2-320630-2 |
| 500 | LOOSE PIECE | 320630 |
| QTY | PACKAGE TYPE | PART NO |

| | | | | | | | |
|--|--|---|--|---|------------------------------------|---|---------------|
| AMP INCORPORATED CUSTOMER SERVICE SYSTEMS | | MAX RECOMMENDED OPERATING TEMPERATURE: 105°C [221°F] | THIS DRAWING IS A CONTROLLED DOCUMENT. | | DWN jr ruth 10JUN09 | TE Connectivity | |
| FOR ADDITIONAL PRODUCT INFORMATION OR COPIES OF DRAWINGS AND TECHNICAL DOCUMENTS | PRODUCT INFORMATION CENTER 1-800-522-6752 | VOLTAGE RATING: 300 V MAX | DIMENSIONS: INCHES | TOLERANCES UNLESS OTHERWISE SPECIFIED: | CHK TOM MICHIELUTTI 10JUN09 | NAME | |
| FOR APPLICATION | TOOLING ASSISTANCE CENTER 1-800-722-1111 | CIRCULAR MIL AREA: 1.04-2.62mm² [2,050-5,180] SOLID OR STRANDED | | 0 PLC ± - 1 PLC ± - 2 PLC ± - 3 PLC ± .008 4 PLC ± - ANGLES ± 5° | APVD TOM MICHIELUTTI 10JUN09 | TERMINAL, P.I.D.G., RING TONGUE, WIRE SIZE: 16-14 HD | |
| TOOLING INFORMATION | 1-800-722-1111 | | MATERIAL | FINISH | PRODUCT SPEC UL 486A | SIZE | RESTRICTED TO |
| FOR ORDER ENTRY | 1-800-526-5142 | THIS DRAWING IS A CONTROLLED DOCUMENT FOR AMP INCORPORATED. IT IS SUBJECT TO CHANGE AND THE CONTROLLING ENGINEERING ORGANIZATION SHOULD BE CONTACTED FOR THE LATEST REVISION. | 3 | 4 | APPLICATION SPEC | CAGE CODE | |
| | | | | | WEIGHT | DRAWING NO | |
| | | | | | CUSTOMER DRAWING | 00779 | |
| | | | | | | 320630 | |
| | | | | | | SCALE | |
| | | | | | | 6:1 | |
| | | | | | | SHEET | |
| | | | | | | 1 OF 1 | |
| | | | | | | REV | |
| | | | | | | E2 | |