

DRAWING MADE IN THIRD ANGLE PROJECTION
 THIS DRAWING IS UNPUBLISHED. RELEASED FOR PUBLICATION .19
 © COPYRIGHT 19 BY AMP INCORPORATED. ALL INTERNATIONAL RIGHTS RESERVED.

LOC		DIST		ZONE		LTR		REVISIONS		DATE	APPD
AF	50							A	REL -1 PER 0710-0370-95	28AUG95	MF/NN

- 1 CONTINUOUS STRIP ON REELS WITH TERMINALS LOCATED ON 5.08±0.08 [.200±.003] CENTERS.
- △2 SLOT ACCEPTS 0.51-0.64mm [#24-#22] AWG COPPER MAGNET WIRE SINGLE WIRE ONLY.
- △3 IDENTIFICATION NUMBER 13 FOR WIRE SLOT SIZE.
- △4 0.00203 [.000080] - 0.00381 [.000150] TIN PER MIL-T-10727 OVER 0.00254 [.000100] - 0.00508 [.000200] COPPER UNDERPLATE PER MIL-C-14550.

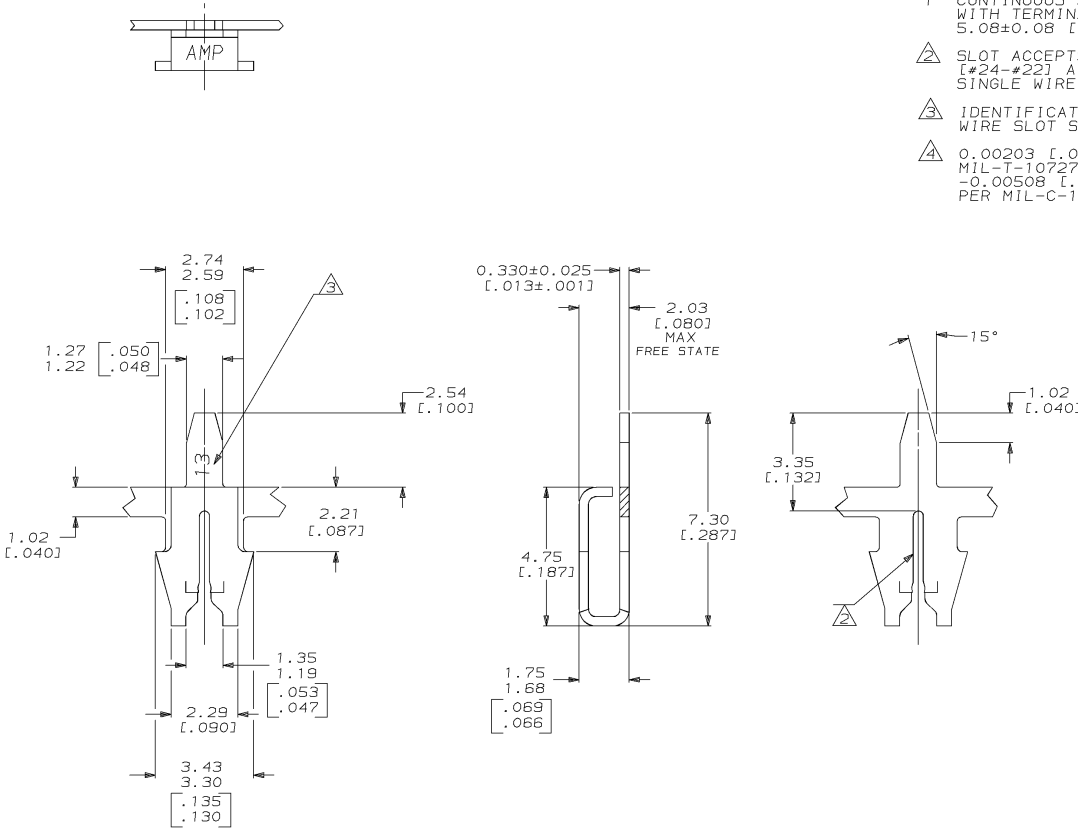

THIS DRAWING IS A CONTROLLED DOCUMENT FOR AMP INCORPORATED. IT IS SUBJECT TO CHANGE AND THE CONTROLLING ENGINEERING ORGANIZATION SHOULD BE CONTACTED FOR THE LATEST REVISION.

		63819-1		PART NO	
DO NOT SCALE PRINT. UNLESS SPECIFIED DIMENSIONS IN mm [INCHES] TOLERANCES ON + 2 PLC DEC # 0.13 (.005) 3 PLC DEC # - ANGLES ± 1°		DR 29/OCT/94 MICHAEL S. FEHER CHK 31/OCT/94 JEFF R. RUTH APPD 31/OCT/94 NELSON E. NEFF		AMP AMP Incorporated Harrisburg, PA 17105-3608	
MATERIAL H04 BRASS		APPD 31/OCT/94 TERRY L. SHUTTER PRODUCT SPEC 108-2012		NAME TERMINAL, POSTED, MAG-MATE™	
FINISH △4		APPLICATION SPEC 114-2069		SIZE C	CAGE CODE 00779
		WEIGHT -		DRAWING NO C-63819	SHEET 1 OF 1
				SCALE 10:1	