Socket, Mini DIMM, 0.60mm Pitch, 244CKTS, R/A

1. SCOPE

1.1. Content

This specification covers performance, tests and quality requirements for the Tyco Electronics 244 position surface mount Mini Dual In-Line Memory Module (DIMM) Right Angled socket used to connect the Mini DIMM module to the motherboard.

1.2. Qualification

When tests are performed on the subject product line, procedures specified in paragraph 3.6 shall be used. All inspections shall be performed using the applicable inspection plan and product drawing.

2. APPLICABLE DOCUMENTS

The following documents form a part of this specification to the extent specified herein. Unless otherwise specified, the latest edition of the document applies. In the event of conflict between the requirements of this specification and the product drawing, the product drawing shall take precedence. In the event of conflict between the requirements of this specification and the referenced documents, this specification shall take precedence.

2.1. Tyco Electronics Documents

- 109-197 AMP Test Specifications vs. EIA and IEC Test Methods
- 114-51011 Application Specification
- 501-51082 Qualification Test Report

2.2. Commercial Standards

- EIA-364 Electrical Connector/Socket Test Procedures Including Environmental Classifications
- EIA/JESD22-B102 Solderability
- MO-244 244 Pin DDR2 Mini DIMM, 0.60 Lead Centers
- E28476 UL Report on Component - Connectors For Use In Data, Signal, Control And Power Applications

3. REQUIREMENTS

3.1. Design and Construction

Product shall be of the design, construction and physical dimensions specified on the applicable product drawing.

3.2. Materials

Materials used in the construction of this product shall be as specified on the applicable product drawing.

3.3. Ratings

- Voltage: 30 volts RMS at 60 Hz
- Current: 1.0 Amp at 30°C temperature rise
- Operating Temperature: -55 to +125°C
(Including Temperature Rise)

3.4. Storage Conditions of Products

Generally, Tyco Electronics products should not be exposed to extreme high temperatures, high humidity or damaging media such as sulphurous, acid or basic atmospheres.

Unless other specific requirements are documented, Tyco Electronics recommends, in accordance with EN 60068-1 as standard atmospheric conditions, a storage temperature between 15°C (59°F) and 35°C (95°F) and a relative humidity between 25% and 75%.

3.5. Performance and Test Description

Product is designed to meet the electrical, mechanical and environmental performance requirements specified in paragraph 3.6.

Unless otherwise specified, all tests shall be performed at ambient environmental conditions per EIA-364.

3.6. Test Requirements and Procedures Summary

S/n	Test Items	Requirements	Procedures
3.6.1	Initial Examination of Product.	Meets requirements of product drawing.	Visual and dimensional inspection per product drawing. EIA-364-18.
3.6.2	Final Examination of Product.	Meets visual requirements.	Visual inspection. EIA-364-18.
Electrical Requirements			
3.6.3	Termination Resistance.	50 milliohms maximum initial. ΔR 10 milliohms maximum increase.	Subject mated contacts assembled in housing to 20 mV maximum open circuit at 100 mA maximum. EIA-364-23.
3.6.4	Temperature Rise at Rated Current.	Maximum of 30°C temperature rise.	1.0 A per contact. 6 consecutive contacts link in series. Mated connector at rated current for 96 hours. EIA-364-70, Method 1.
3.6.5	Insulation Resistance.	1000 megaohms minimum.	500 VDC. Test between adjacent contacts of unmated and unmounted specimens. EIA-364-21.
3.6.6	Dielectric Withstanding Voltage.	No breakdown or flashover.	500 volts AC at sea level with 1 minute hold. Test between adjacent contacts of unmated and unmounted specimens. EIA-364-20, Condition I.

S/n	Test Items	Requirements	Procedures
Mechanical Requirements			
3.6.7	Solderability.	Solderable area shall have minimum of 95% solder coverage.	Subject specimens to solderability test. EIA/JESD22-B102, Method 2, (Steam Aging Condition C).
3.6.8	Vibration.	No discontinuities of 1 microsecond or longer duration; measured in accordance with EIA-364-46. See Note.	Subject specimens mated with test board module to a simple harmonic motion. Amplitude: 1.52mm (peak to peak) Frequency range: 10-55-10 Hz in one min. Duration: 2 hrs each on X, Y and Z axes. (Total 6 hrs) See Figure 1. EIA-364-28, Test Condition I.
3.6.9	Mechanical Shock, Specified Pulse.	No discontinuities of 1 microsecond or longer duration; measured in accordance with EIA-364-46. See Note.	Subject specimens mated with test board module to 30 g's half-sine waveform shock pulses of 11 milliseconds duration. 3 shocks in each direction applied along 3 mutually perpendicular planes, 18 total shocks. See Figure 1. EIA-364-27, Method H.
3.6.10	Durability.	See Note.	Mate and unmate specimens for 25 cycles at a maximum rate of 600 cycles per hour. EIA-364-9.
3.6.11	Module Insertion Force.	24.20 kgf max.	Insert a 1.00mm thick Module at a rate of 25 ± 6 mm per minute. See JEDEC MO-244 for Module PCB details.
3.6.12	Module Rip-out Force.	3.60 kgf min.	Extract a 1.00mm thick Module at a rate of 25 ± 6 mm per minute from a mated connector with both latches closed. See JEDEC MO-244 for Module PCB details.

S/n	Test Items	Requirements	Procedures
Environmental Requirements			
3.6.13	Thermal Shock.	See Note.	Subject mated specimens to 5 cycles between -55 and +125°C, with dwell time of 20 minutes at both extremes. EIA-364-32.
3.6.14	Temperature/Humidity Cycling.	See Note.	Subject mated but unpowered specimens to 10 cycles (240 hours) at 25°C to 65°C, and at 95% RH. EIA-364-31, Method III, omitting only sub-cycle 7b (vibration).
3.6.15	Temperature Life.	See Note.	Subject mated, but unpowered, specimens to temperature life at +105°C for 72 hours. EIA-364-17.
3.6.17	Heat Resistance to Lead-Free Reflow Soldering.	Housing shall be free from deformation and fusion. All components of the product, e.g. plastic materials, platings and contacts, shall be free from significant discoloration.	Pre-Heat: 150~200°C; 60 sec min. Heat: 217°C MIN; 60 sec min. Peak Temperature: 260°C max. Spec. 109-201, Cond. B. omitting moisture soak.

NOTE Shall meet visual requirements, show no physical damage, and meet requirements of additional tests as specified in the Product Qualification and Re-qualification Test Sequence shown in paragraph 3.7.

3.7. Product Qualification and Re-qualification Test Sequence

Test Items	Test Group (a)							
	1	2	3	4	5	6	7	8
	Test Sequence (b)							
Initial examination of product	1	1	1	1	1	1	1	1
Termination resistance	2, 4	2, 6	2, 6		2, 4, 7	2, 4		
Temperature rise at rated current.	3							
Insulation resistance		3, 7	3, 7					
Dielectric withstanding voltage		4, 8	4, 8					
Solderability				2				
Vibration					5			
Mechanical shock					6			
Durability						3		
Thermal shock		5						
Humidity-temperature cycling			5					
Temperature life					3			
Module Insertion Force.							2	
Module Rip-out Force.							3	
Heat Resistance to Lead-Free Reflow Soldering.								2
Final examination of product	5	9	9	3	8	5	4	3
Sample size	5	5	5	5	5	5	5	5

NOTES

(a) See Paragraph 4.1.A.

(b) Numbers indicate sequence in which tests are performed.

4. QUALITY ASSURANCE PROVISIONS

4.1. Qualification Testing

A. Specimen Selection

Specimens shall be prepared in accordance with applicable Instruction Sheets and shall be selected at random from current production.

B. Test Sequence

Qualification inspection shall be verified by testing specimens as specified in Paragraph 3.7.

4.2. Re-qualification Testing

If changes significantly affecting form, fit or function are made to the product or manufacturing process, product assurance shall coordinate re-qualification testing, consisting of all or part of the original testing sequence as determined by development/product, quality and reliability engineering.

4.3. Acceptance

Acceptance is based on verification that the product meets the requirements of Paragraph 3.6. Failures attributed to equipment, test setup or operator deficiencies shall not disqualify the product. When product failure occurs, corrective action shall be taken and specimens resubmitted for qualification. Testing to confirm corrective action is required before resubmitting.

4.4. Quality Conformance Inspection

The applicable quality inspection plan shall specify the sampling acceptable quality level to be used. Dimensional and functional requirements shall be in accordance with the applicable product drawing and this specification.

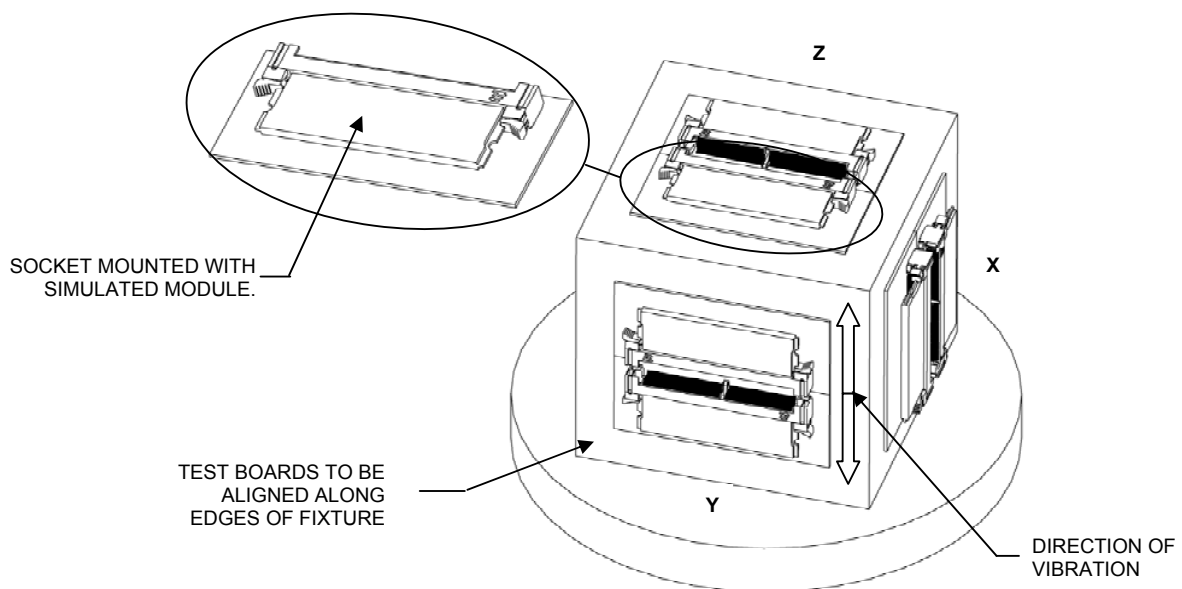

Figure 1
Vibration & Mechanical Shock Mounting Fixture