

NOT DRAWING TO DIMENSIONS
 RELEASED FOR RELEASE
 COPYRIGHT © BY THIS ELECTRONIC COMPONENTS, LLC. ALL RIGHTS RESERVED

REVISED		REVISIONS			
REV	DATE	DESCRIPTION	BY	CHK	APP
D		RELEASED FOR 00-0162-00	RELIUS	HS	CS
A		REVISED FOR 00-0053-01	MAY 05 00	HS	CS
B		REVISED FOR 00-0104-01	OCT 20 00	HS	CS
C		REVISED FOR 00-0136-01	NOV 23 00	HS	CS
D		REVISED FOR 00-0145-01	JAN 23 00	HS	CS
E		REVISED FOR 00-0008-03	JAN 23 00	HS	CS
F		REVISED FOR 07-008980	APR 28 07	YH	JK

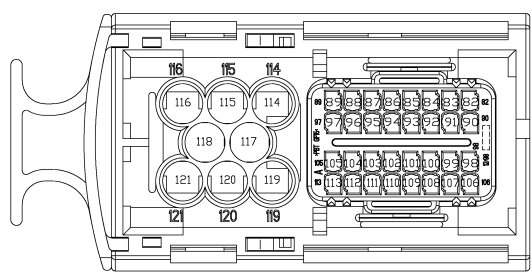
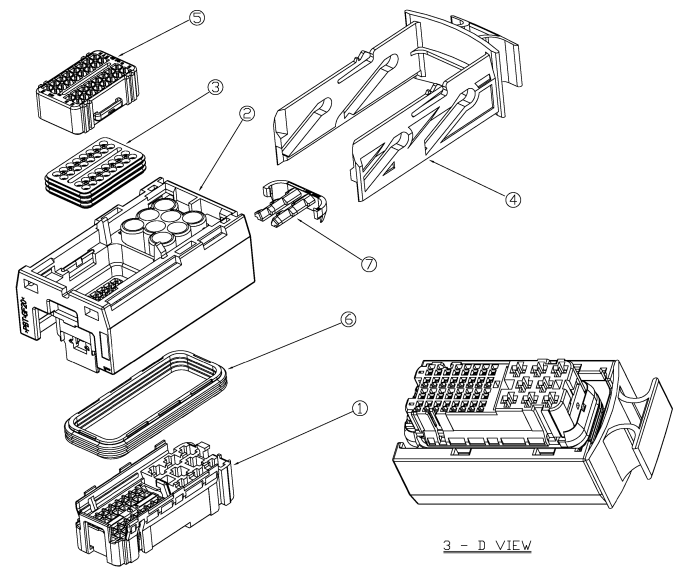
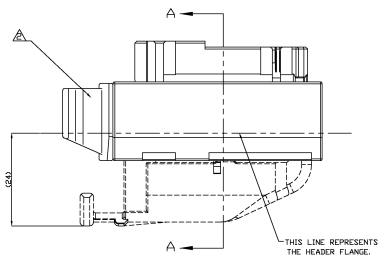
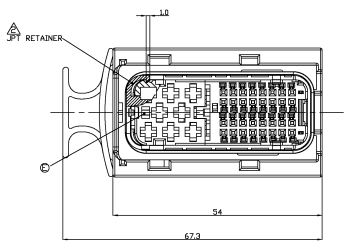
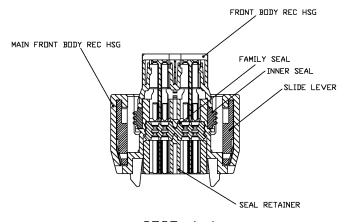

368383-4	82,83,86,87,88,90,91, 97,105,111,112	④④④
368383-3	82,84,86,87,90,91,95,96, 98,100,103,104,111,112	④
368383-2	82,84,86,87,89-92,94-98, 100,103-105,111-113	④
368383-1	-	
PART NUMBER	BLANKED CAVITIES	

- NOTES
- GENERAL TOLERANCE IS ±0.5
 - CONDITION OF DELIVERY : SLIDE LEVER IN CLOSED POSITION, JPT RETAINER IN OPEN POSITION.
 - SUITABLE FOR WIRE SIZE RANGE:

CONTACT	MGS	JPT
CIRCUIT NO.	82 - 113 114 - 121	
WIRE SIZE(mm ²)	0.5 - 0.75 0.5 - 2.5	
 - APPLIED COVER HSG P/N 368401

CONTACT	MGS	JPT
Part NO.	968220 968221 964286 964273	
WIRE SIZE(mm ²)	0.5 - 0.75 0.5 - 1.0 1.0 - 2.5	
 - APPLIED RECEPTACLE CONTACT P/N

CONTACT	MGS	JPT
Part NO.	968220 968221 964286 964273	
WIRE SIZE(mm ²)	0.5 - 0.75 0.5 - 1.0 1.0 - 2.5	
 - APPLIED HEADER ASSEMBLY P/N 368146

NO	Part No.	DESCRIPTION	MATERIAL	CLS OR QTY	ASSY P/N	DESCRIPTION	ASSY REC HSG ASSY	ASSY REC HSG ASSY	ASSY REC HSG ASSY	ASSY REC HSG ASSY
7	368381-1	JPT RETAINER FOR 40P	PBT-GF30	YELLOW	1	1	1	1	1	1
6	368907-1	INNER SEAL FOR 48P	SILICONE	DRANGE	1	1	1	1	1	1
	368387-4			BLUE	1	1	1	1	1	1
	368387-3			WHITE	1	1	1	1	1	1
5	368387-2	SEAL RETAINER FOR 40P	PBT-GF15	GRAY	1	1	1	1	1	1
	368387-1			BLACK	1	1	1	1	1	1
4	368386-1	SLIDE LEVER FOR 40P	PA66-GF35	BLACK	1	1	1	1	1	1
3	368906-1	38P FAMILY SEAL	SILICONE	DRANGE	1	1	1	1	1	1
2	368385-1	MAIN BODY REC. HSG FOR 48P	PBT-GF20	BLACK	1	1	1	1	1	1
1	368384-1	FRONT BODY REC. HSG FOR 40P	PA66-GF15	BLACK	1	1	1	1	1	1

ND Part No. DESCRIPTION MATERIAL CLS OR QTY

WORLDWIDE DISTRIBUTION: AMP KOREA, Kyungson, Korea

ORIENTED: UN

REWORK LABEL: NONE

REWORK SPEC: 08-6309

APPLICATION SPEC: 114-18050, 114-18051-1

WARRANTY: 1 YEAR

DATE CODE: 0779

REVISED TO: 368383

CUSTOMER DRAWING: 21 SHEET 1 OF 1