

## High current MOSFET driver

### Features

- Dual MOSFET driver for synchronous rectified converters
- High driving current for fast external MOSFET switching
- Integrated bootstrap diode
- High frequency operation
- Enable pin
- Adaptive dead-time management
- Flexible gate-drive: 5 V to 12 V compatible
- High-impedance (HiZ) management for output stage shutdown
- Preliminary overvoltage (OV) protection
- VFDFPN8 3x3 mm package

### Applications

- High current VRM / VRD for desktop / server / workstation CPUs
- High current and high efficiency DC-DC converters

### Description

The L6747A is a flexible, high-frequency dual-driver specifically designed to drive N-channel MOSFETs connected in synchronous-rectified buck topology.

Combined with ST PWM controllers, the driver allows the implementation of complete voltage

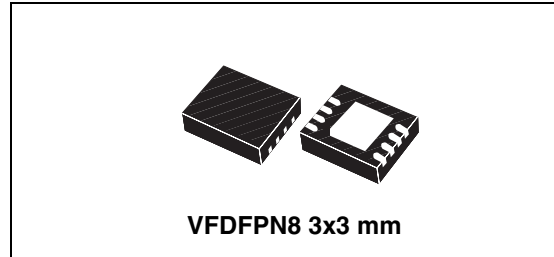

regulator solutions for modern high-current CPUs and for DC-DC conversion in general.

The L6747A embeds high-current drivers for both high-side and low-side MOSFETs. The device accepts a flexible power supply of 5 V to 12 V. This allows optimization of the high-side and low-side gate-drive voltage to maximize system efficiency.

The embedded bootstrap diode eliminates the need for external diodes. Anti shoot-through management prevents the high-side and low-side MOSFETs from conducting simultaneously and, combined with adaptive dead-time control, minimizes the LS body diode conduction time.

The L6747A features preliminary OV protection to protect the load from dangerous overvoltage due to MOSFET failures at startup.

The L6747A device is available in a VFDFPN8 3x3 mm package.

**Table 1. Device summary**

Order code	Package	Packing
L6747A	VFDFPN8	Tube
L6747ATR	VFDFPN8	Tape and reel

---

# Contents

<b>1</b>	<b>Typical application circuit and block diagram</b>	<b>3</b>
<b>2</b>	<b>Pin information and thermal data</b>	<b>4</b>
2.1	Pin information	4
2.2	Thermal data	5
<b>3</b>	<b>Electrical specifications</b>	<b>6</b>
3.1	Absolute maximum ratings	6
3.2	Electrical characteristics	6
<b>4</b>	<b>Device description and operation</b>	<b>8</b>
4.1	High-impedance (HiZ) management	9
4.2	Preliminary OV protection	9
4.3	BOOT capacitance design	9
4.4	Power dissipation	10
4.5	Layout guidelines	11
<b>5</b>	<b>Package mechanical data</b>	<b>13</b>
<b>6</b>	<b>Revision history</b>	<b>14</b>



## 2 Pin information and thermal data

### 2.1 Pin information

Figure 3. Pin connection diagram (top view)

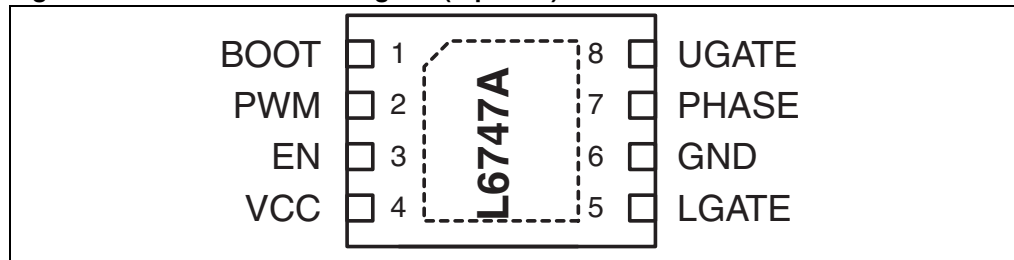

Table 2. Pin descriptions

Pin #	Name	Function
1	BOOT	High-side driver supply. This pin supplies the high-side floating driver. Connect through a $R_{BOOT}$ - $C_{BOOT}$ (2.2 $\Omega$ - 220nF typ.) network to the PHASE pin. Internally connected to the cathode of the integrated bootstrap diode. See <a href="#">Section 4.3</a> for guidance in selecting the capacitor value.
2	PWM	Control input for the driver; 5V compatible, internally clamp to 3.3V. This pin controls the state of the driver and which external MOSFET must be turned ON according to EN status. It manages the high-impedance (HiZ) state which sets all the MOSFETs to OFF if externally set in the HiZ window (see <a href="#">Table 5</a> ). See <a href="#">Section 4.1</a> for details of HiZ.
3	EN	Enable input for the driver; 5V compatible, internally clamp to 3.3V. Pull high to enable the driver based on the PWM status. Pull low to enter HiZ state with all MOSFETs OFF, regardless of the PWM status. See <a href="#">Section 4.1</a> for details of HiZ.
4	VCC	Device and LS driver power supply. Connect to any voltage between 5V and 12V. Bypass with low-ESR MLCC capacitor to GND (1 $\mu$ F typ).
5	LGATE	Low-side driver output. Connect directly to the low-side MOSFET gate. A small series resistor may be used to reduce dissipated power, especially in high frequency applications.
6	GND	All internal references, logic and drivers are referenced to this pin. Connect to the PCB ground plane.
7	PHASE	High-side driver return path. Connect to the high-side MOSFET source. This pin is also monitored for adaptive dead-time management and pre-OV protection. Internal clamp circuitry prevents leakage from this pin in disable conditions.

**Table 2. Pin descriptions (continued)**

Pin #	Name	Function
8	UGATE	High-side driver output. Connect to high-side MOSFET gate. A small series resistor may be used to control the PHASE pin negative spike.
-	TH. PAD	Thermal pad connects the silicon substrate and makes good thermal contact with the PCB. Connect to the PGND plane.

## 2.2 Thermal data

**Table 3. Thermal data**

Symbol	Parameter	Value	Unit
$R_{THJA}$	Thermal resistance junction-to-ambient (device soldered on 2s2p, 67mm x 69mm board)	45	°C/W
$R_{THJC}$	Thermal resistance junction-to-case	5	°C/W
$T_{MAX}$	Maximum junction temperature	150	°C
$T_{STG}$	Storage temperature range	0 to 150	°C
$T_J$	Junction temperature range	0 to 125	°C
$P_{TOT}$	Maximum power dissipation at 25°C (device soldered on 2s2p, 67mm x 69mm board)	2.25	W

### 3 Electrical specifications

#### 3.1 Absolute maximum ratings

Table 4. Absolute maximum ratings

Symbol	Parameter	Value	Unit
$V_{CC}$	to GND	-0.3 to 18	V
$V_{BOOT}$	to GND to GND, $t < 200$ ns to PHASE	-0.3 to 41 -0.3 to 44 -0.3 to 15	V
$V_{UGATE}$	$t < 200$ ns	PHASE -0.3 to BOOT +0.3 PHASE -1 to BOOT +0.3	V
$V_{PHASE}$	to GND to GND; $t < 200$ ns, $V_{CC} = 12V$	-8 to 26 -8 to 30	V
$V_{LGATE}$	to GND to GND, $t < 200$ ns	-0.3 to $V_{CC} + 0.3$ -1.5 to $V_{CC} + 0.3$	V
$V_{PWM}, V_{EN}$	to GND	-0.3 to 7	V

#### 3.2 Electrical characteristics

$V_{CC} = 12 V \pm 15\%$ ,  $T_J = 0\text{ }^\circ\text{C}$  to  $70\text{ }^\circ\text{C}$  unless otherwise specified.

Table 5. Electrical characteristics

Symbol	Parameter	Test conditions	Min.	Typ.	Max.	Unit
<b>Supply current and power-on</b>						
$I_{CC}$	VCC supply current	UGATE = LGATE = OPEN; BOOT = 12V; EN = 1; PWM = 1		1.5	2.0	mA
		UGATE = LGATE = OPEN; BOOT = 12V; EN = 1; PWM = 0		2.7	3.5	mA
		UGATE = LGATE = OPEN; BOOT = 12V; EN = 0		1.0	1.5	mA
$I_{BOOT}$	BOOT supply current	UGATE = OPEN; PHASE = GND; BOOT = 12V; EN = 1; PWM = 1		2.3	3.3	mA
		UGATE = OPEN; PHASE = GND; BOOT = 12V; EN = 1; PWM = 0		2.0	3.0	mA
		UGATE = OPEN; PHASE = GND; BOOT = 12V; EN = 0		1.3	2.3	mA
$UVLO_{VCC}$	VCC turn-ON	VCC rising			4.1	V
	VCC turn-OFF	VCC falling	3.5			V

Table 5. Electrical characteristics (continued)

Symbol	Parameter	Test conditions	Min.	Typ.	Max.	Unit
<b>PWM and EN input</b>						
PWM	Input high - $V_{PWM\_IH}$	PWM rising	2			V
	Input low - $V_{PWM\_IL}$	PWM falling			0.8	V
	Input leakage	PWM = GND	-5		5	$\mu$ A
$t_{HiZ}$	HiZ hold-off time	See <a href="#">Figure 4</a>		120		ns
$t_{prop\_L}$	Propagation delays	See <a href="#">Figure 4</a>		25	35	ns
$t_{prop\_H}$				30	45	ns
EN	Input high - $V_{EN\_IH}$	EN rising	2			V
	Input low - $V_{EN\_IH}$	EN falling			0.8	V
<b>Gate drivers</b>						
$R_{HIHS}$	HS source resistance	BOOT - PHASE = 12V; 100mA		1.4	2.0	$\Omega$
$I_{UGATE}$	HS source current <sup>(1)</sup>	BOOT - PHASE = 12V; $C_{UGATE}$ to PHASE = 3.3nF		3.5		A
$R_{LOHS}$	HS sink resistance	BOOT - PHASE = 12V; 100mA		1.0	1.5	$\Omega$
$R_{HILS}$	LS source resistance	100mA		1.4	2.0	$\Omega$
$I_{LGATE}$	LS source current <sup>(1)</sup>	$C_{LGATE}$ to GND = 5.6nF		3.5		A
$R_{LOLS}$	LS sink resistance	100mA		1.0	1.5	$\Omega$
<b>Protections</b>						
$V_{PRE\_OV}$	Pre-OV threshold	PHASE rising	1.7	1.8		V

1. Parameter(s) guaranteed by design, not fully tested in production

## 4 Device description and operation

The L6747A provides high-current driving control for both high-side and low-side N-channel MOSFETs, connected as step-down DC-DC converters and driven by an external PWM signal. The integrated high-current drivers allow the use of different types of power MOSFETs (also multiple MOS to reduce the equivalent  $R_{DS(on)}$ ), maintaining fast switching transition. The driver for the high-side MOSFET uses the BOOT pin for supply and the PHASE pin for return. The driver for the low-side MOSFET uses the VCC pin for supply and the PGND pin for return.

The driver includes anti-shoot-through and adaptive dead-time control to minimize low-side body diode conduction time, maintaining good efficiency and eliminating the need for Schottky diodes. When the high-side MOSFET turns off, the voltage on its source begins to fall; when the voltage falls below the proper threshold, the low-side MOSFET gate drive voltage is suddenly applied. When the low-side MOSFET turns off, the voltage at the LGATE pin is sensed. When it drops below the proper threshold, the high-side MOSFET gate drive voltage is suddenly applied. If the current flowing in the inductor is negative, the source of the high-side MOSFET never drops. To allow the low-side MOSFET to turn on even in this case, a watchdog controller is enabled. If the source of the high-side MOSFET does not drop, the low-side MOSFET is switched on, allowing the negative current of the inductor to recirculate. This mechanism allows the system to regulate even if the current is negative.

Before  $V_{CC}$  goes above the UVLO threshold, the L6747A keeps both the high-side and low-side MOSFETs firmly OFF. Then, after the UVLO has been crossed, the EN and PWM inputs take control over the driver's operations.

The EN pin enables the driver. If low, it keeps all MOSFETs OFF (HiZ) regardless of the status of PWM. When EN is high, the PWM input takes control. If externally set within the HiZ window, the driver enters an HiZ state and both MOSFETs are kept in an OFF state until PWM exits the HiZ window (see [Figure 4](#)).

After the UVLO threshold has been crossed and while in HiZ, the preliminary OV protection is activated. If the voltage sensed through the PHASE pin goes above about 1.8 V, the low-side MOSFET is latched ON in order to protect the load from dangerous overvoltage. The driver status is reset from a PWM transition.

Driver power supply, as well as power conversion input, are flexible: 5 V and 12 V can be chosen for high-side and low-side MOSFET voltage drive.

**Figure 4. Timing diagram (EN = high)**

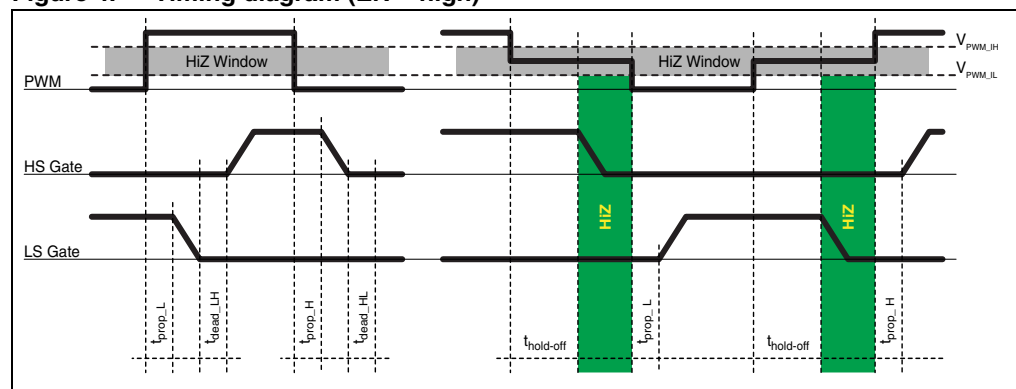



## 4.1 High-impedance (HiZ) management

The driver is capable of managing a high-impedance conditions by keeping all MOSFETs in an OFF state. This is achieved in two different ways:

- If the EN signal is pulled low, the device keeps all MOSFETs OFF regardless of the PWM status.
- When EN is asserted, if the PWM signal is externally set within the HiZ window for a time greater than the hold-off time, the device detects the HiZ condition and turns off all the MOSFETs. The HiZ window is defined as the PWM voltage range between  $V_{\text{PWM\_HIZ\_H}} = 1.6 \text{ V}$  and  $V_{\text{PWM\_HIZ\_L}} = 1.3 \text{ V}$ .

The device exits from the HiZ state after any PWM transition. See [Figure 4](#) for details about HiZ timing.

The implementation of the high-impedance state allows the controller connected to the driver to manage the high-impedance state of its output, preventing the generation of negative undershoot on the regulated voltage during the shutdown stage. Also, different power management states may be managed, such as pre-bias startup.

## 4.2 Preliminary OV protection

When  $V_{\text{CC}}$  exceeds its UVLO threshold while the device is in HiZ, the L6747A activates the preliminary OV protection.

The intent of this protection feature is to protect the load during system startup, especially from high-side MOSFET failures. In fact, VRM, and more generally PWM, controllers, have a 12 V bus-compatible turn-on threshold and are non-operative if  $V_{\text{CC}}$  is below the turn-on thresholds (which is in the range of about 10 V). In cases of high-side MOSFET failure, the controller does not recognize the overvoltage until  $V_{\text{CC}} = \sim 10 \text{ V}$  (unless other special features are implemented). However, in this case the output voltage is already at the same voltage ( $\sim 10 \text{ V}$ ) and the load (a CPU in most cases) is already burnt.

The L6747A bypasses the PWM controller by latching on the low-side MOSFET if the PHASE pin voltage exceeds 1.8 V during the HiZ state. When the PWM input exits from the HiZ window, the protection is reset and the control of the output voltage is transferred to the controller connected to the PWM input.

Since the driver has its own UVLO threshold, a simple way to provide protection to the output in all conditions when the device is OFF is to supply the controller through the 5  $V_{\text{SB}}$  bus. 5  $V_{\text{SB}}$  is always present before any other voltage and, in case of high-side short, the low-side MOSFET is driven with 5 V. This ensures reliable protection of the load.

Preliminary OV is active after UVLO and while the driver is in an HiZ state, and it is disabled after the first PWM transition. The controller must manage its output voltage from that moment on.

## 4.3 BOOT capacitance design

The L6747A embeds a bootstrap diode to supply the high-side driver, removing the necessity for an external component. Simply connecting an external capacitor between BOOT and PHASE completes the high-side supply connections.

The bootstrap capacitor value should be selected to obtain a negligible discharge due to the turning on of the high-side MOSFET. It must provide a stable voltage supply to the high-side driver during the MOSFET turn-on, and minimize the power dissipated by the embedded boot diode. *Figure 5* illustrates some guidelines on how to select the capacitance value for the bootstrap according to the desired discharge, and the selected MOSFET.

To prevent the bootstrap capacitor from overcharging as a consequence of large negative spikes, an external series  $R_{BOOT}$  resistor (in the range of few ohms) may be required in series with the BOOT pin.

**Figure 5. Bootstrap capacitance design**

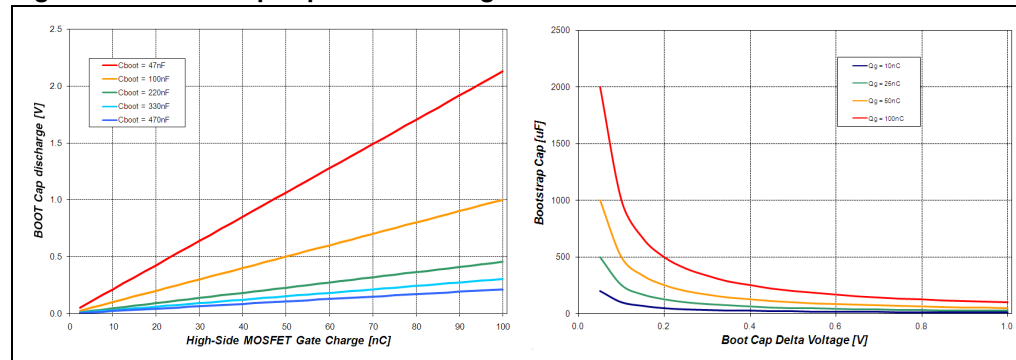

## 4.4 Power dissipation

The L6747A embeds high current drivers for both high-side and low-side MOSFETs. It is therefore important to consider the power that the device is going to dissipate in driving them in order to avoid exceeding the maximum junction operating temperature.

Two main factors contribute to device power dissipation: bias power and driver power.

- Device power ( $P_{DC}$ ) depends on the static consumption of the device through the supply pins and is easily quantifiable as follows:

$$P_{DC} = V_{CC} \cdot I_{CC} + V_{PVCC} \cdot I_{PVCC}$$

- Driver power is the power needed by the driver to continuously switch the external MOSFETs ON and OFF. It is a function of the switching frequency and total gate charge of the selected MOSFETs. It can be quantified considering that the total power  $P_{SW}$  dissipated to switch the MOSFETs is influenced by three main factors: external gate resistance (when present), intrinsic MOSFET resistance, and intrinsic driver resistance. This last factor is the important one to be determined to calculate the device power dissipation.

The total power dissipated to switch the MOSFETs is:

$$P_{SW} = F_{SW} \cdot (Q_{GHS} \cdot PVCC + Q_{GLS} \cdot VCC)$$

When designing an application based on the L6747A, it is recommended to take into consideration the effect of external gate resistors on the power dissipated by the driver. External gate resistors help the device to dissipate the switching power since the same power  $P_{SW}$  is shared between the internal driver impedance and the external resistor, resulting in a general cooling of the device.

Referring to [Figure 6](#), a classic MOSFET driver can be represented by a push-pull output stage with two different MOSFETs: a P-MOSFET to drive the external gate high, and an N-MOSFET to drive the external gate low (with their own  $R_{DS(on)}$ :  $R_{hi\_HS}$ ,  $R_{lo\_HS}$ ,  $R_{hi\_LS}$ ,  $R_{lo\_LS}$ ). The external power MOSFET can be represented in this case as a capacitance ( $C_{G\_HS}$ ,  $C_{G\_LS}$ ) that stores the gate-charge ( $Q_{G\_HS}$ ,  $Q_{G\_LS}$ ) required by the external power MOSFET to reach the driving voltage (PVCC for HS and VCC for LS). This capacitor is charged and discharged at the driver switching frequency  $F_{SW}$ .

The total power  $P_{SW}$  is dissipated among the resistive components distributed along the driving path. According to the external gate resistance and the power MOSFET intrinsic gate resistance, the driver dissipates only a portion of  $P_{SW}$  as follows:

$$P_{SW-HS} = \frac{1}{2} \cdot C_{GHS} \cdot PVCC^2 \cdot F_{SW} \cdot \left( \frac{R_{hiHS}}{R_{hiHS} + R_{GateHS} + R_{iHS}} + \frac{R_{loHS}}{R_{loHS} + R_{GateHS} + R_{iHS}} \right)$$

$$P_{SW-LS} = \frac{1}{2} \cdot C_{GLS} \cdot VCC^2 \cdot F_{SW} \cdot \left( \frac{R_{hiLS}}{R_{hiLS} + R_{GateLS} + R_{iLS}} + \frac{R_{loLS}}{R_{loLS} + R_{GateLS} + R_{iLS}} \right)$$

The total power dissipated from the driver can then be determined as follows:

$$P = P_{DC} + P_{SW-HS} + P_{SW-LS}$$

**Figure 6. Equivalent circuit for a MOSFET driver**

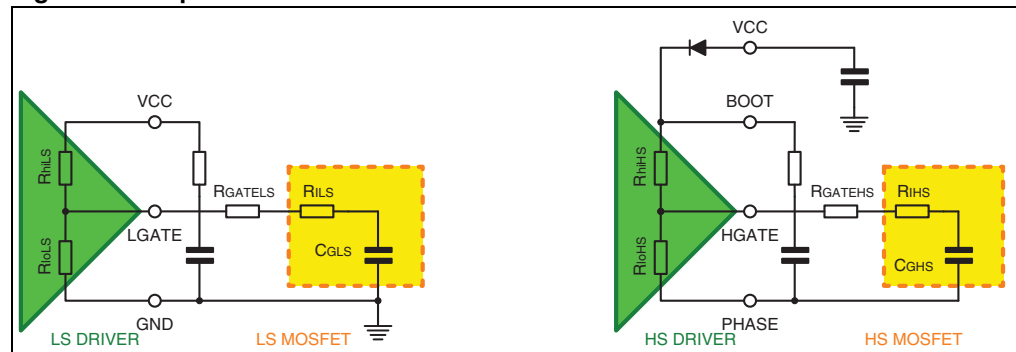

## 4.5 Layout guidelines

The L6747A provides driving capability to implement high-current step-down DC-DC converters.

The first priority when placing components for these applications should be given to the power section, minimizing the length of each connection and loop as much as possible. To minimize noise and voltage spikes (as well as EMI and losses) power connections must be part of a power plane, and in any case constructed with wide and thick copper traces. The loop must be minimized. The critical components, such as the power MOSFETs, must be close to each other. However, some space between the power MOSFETs is required to assure good thermal cooling and airflow.

Traces between the driver and the MOSFETS should be short and wide to minimize the inductance of the trace, which in turn minimizes ringing in the driving signals. Moreover, the VIA count should be minimized to reduce the related parasitic effect.

The use of a multi-layer printed circuit board is recommended.

Small signal components and connections to critical nodes of the application, as well as bypass capacitors for the device supply, are also important. Place the bypass capacitor (VCC, PVCC and BOOT capacitors) close to the device with the shortest possible loop, using wide copper traces to minimize parasitic inductance.

Systems that do not use Schottky diodes in parallel with the low-side MOSFET might show large negative spikes on the PHASE pin. This spike can be limited, as can the positive spike, but has an additional consequence: it causes the bootstrap capacitor to be overcharged. This extra charge can cause, in the worst case condition of maximum input voltage and during particular transients, that boot-to-phase voltage exceeds the absolute maximum ratings causing device failures. It is therefore suggested in these cases to limit this extra charge by adding a small  $R_{BOOT}$  resistor in series with the boot capacitor. The use of  $R_{BOOT}$  also contributes in the limitation of the spike present on the BOOT pin.

For heat dissipation, place the copper area under the IC. This copper area may be connected by internal copper layers through several VIAs to improve thermal conductivity. The combination of copper pad, copper plane and VIAs under the driver allows the device to achieve its best thermal performance.

Figure 7. Driver turn-on and turn-off paths

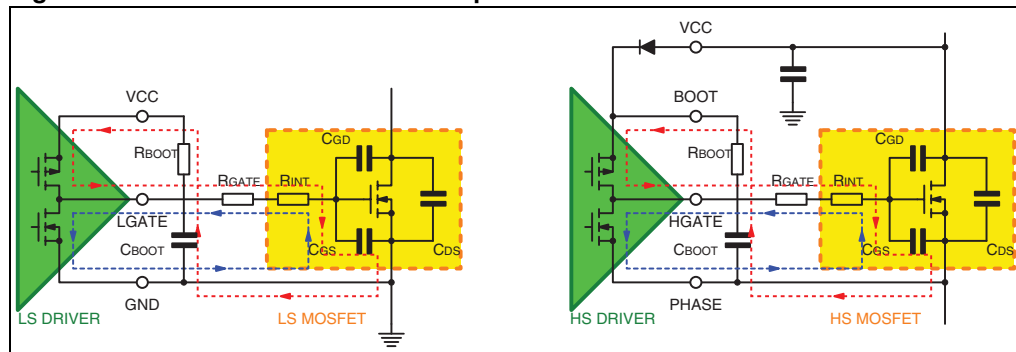
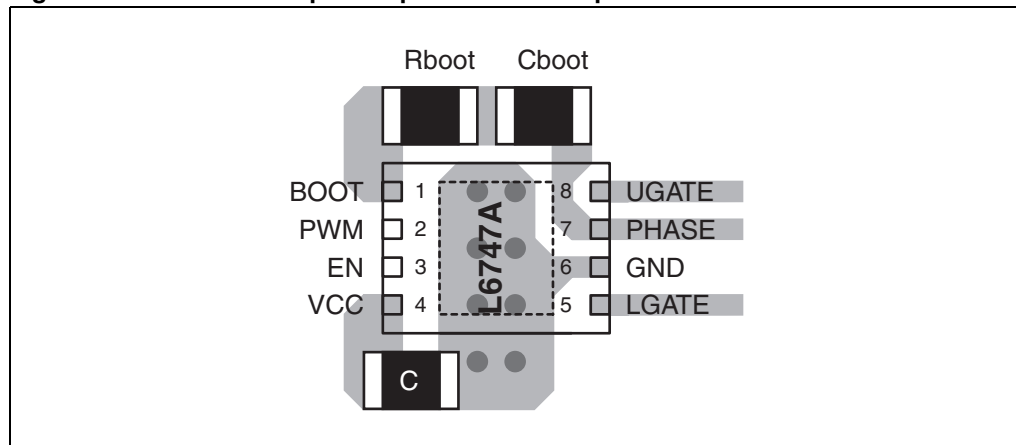

Figure 8. External component placement example



## 5 Package mechanical data

In order to meet environmental requirements, ST offers these devices in different grades of ECOPACK<sup>®</sup> packages, depending on their level of environmental compliance. ECOPACK<sup>®</sup> specifications, grade definitions and product status are available at: [www.st.com](http://www.st.com). ECOPACK<sup>®</sup> is an ST trademark.

**Figure 9. VFDFPN8 mechanical data and package dimensions**

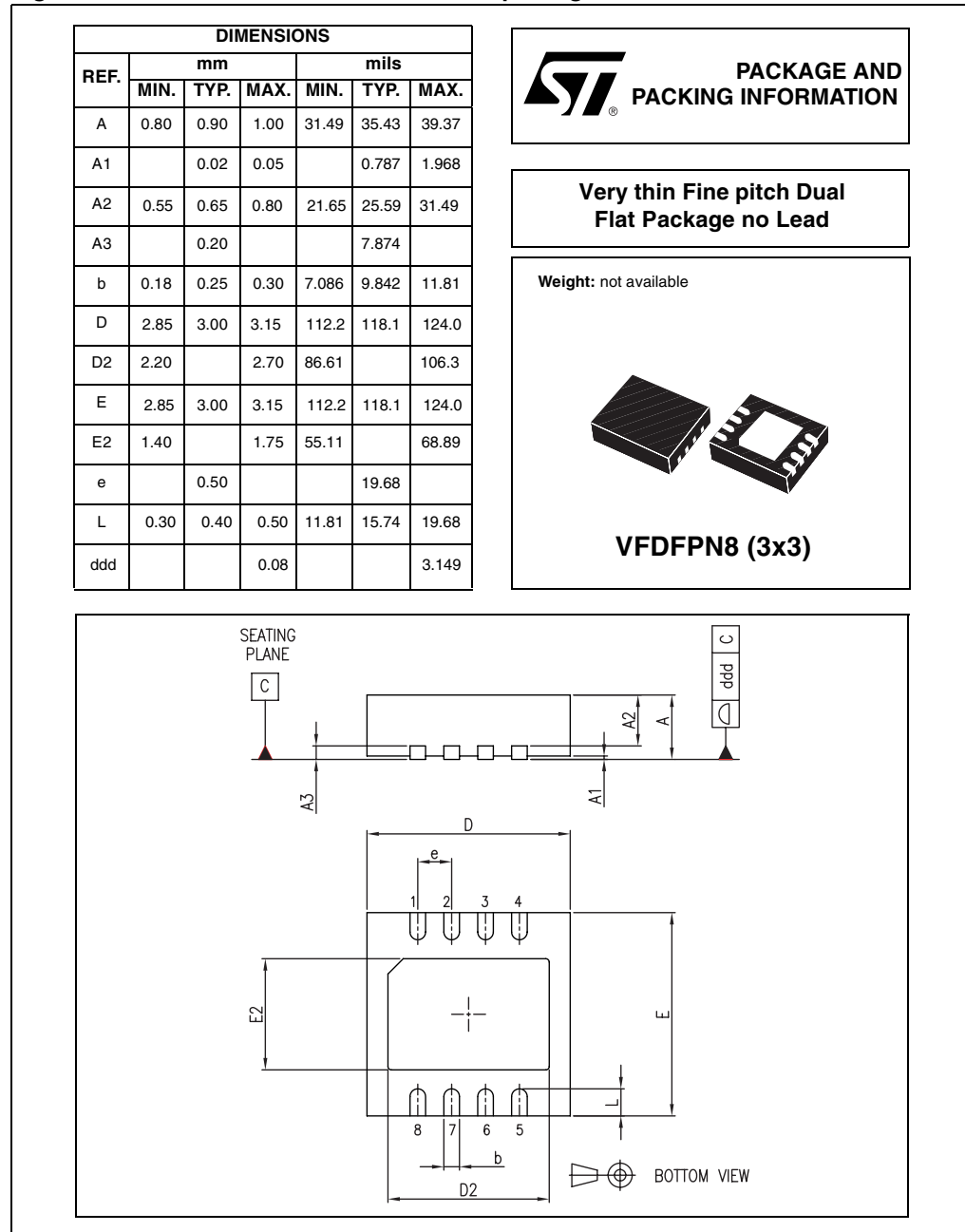

## 6 Revision history

**Table 6. Document revision history**

Date	Revision	Changes
24-Mar-2010	1	Initial release.

**Please Read Carefully:**

Information in this document is provided solely in connection with ST products. STMicroelectronics NV and its subsidiaries ("ST") reserve the right to make changes, corrections, modifications or improvements, to this document, and the products and services described herein at any time, without notice.

All ST products are sold pursuant to ST's terms and conditions of sale.

Purchasers are solely responsible for the choice, selection and use of the ST products and services described herein, and ST assumes no liability whatsoever relating to the choice, selection or use of the ST products and services described herein.

No license, express or implied, by estoppel or otherwise, to any intellectual property rights is granted under this document. If any part of this document refers to any third party products or services it shall not be deemed a license grant by ST for the use of such third party products or services, or any intellectual property contained therein or considered as a warranty covering the use in any manner whatsoever of such third party products or services or any intellectual property contained therein.

**UNLESS OTHERWISE SET FORTH IN ST'S TERMS AND CONDITIONS OF SALE ST DISCLAIMS ANY EXPRESS OR IMPLIED WARRANTY WITH RESPECT TO THE USE AND/OR SALE OF ST PRODUCTS INCLUDING WITHOUT LIMITATION IMPLIED WARRANTIES OF MERCHANTABILITY, FITNESS FOR A PARTICULAR PURPOSE (AND THEIR EQUIVALENTS UNDER THE LAWS OF ANY JURISDICTION), OR INFRINGEMENT OF ANY PATENT, COPYRIGHT OR OTHER INTELLECTUAL PROPERTY RIGHT.**

**UNLESS EXPRESSLY APPROVED IN WRITING BY AN AUTHORIZED ST REPRESENTATIVE, ST PRODUCTS ARE NOT RECOMMENDED, AUTHORIZED OR WARRANTED FOR USE IN MILITARY, AIR CRAFT, SPACE, LIFE SAVING, OR LIFE SUSTAINING APPLICATIONS, NOR IN PRODUCTS OR SYSTEMS WHERE FAILURE OR MALFUNCTION MAY RESULT IN PERSONAL INJURY, DEATH, OR SEVERE PROPERTY OR ENVIRONMENTAL DAMAGE. ST PRODUCTS WHICH ARE NOT SPECIFIED AS "AUTOMOTIVE GRADE" MAY ONLY BE USED IN AUTOMOTIVE APPLICATIONS AT USER'S OWN RISK.**

Resale of ST products with provisions different from the statements and/or technical features set forth in this document shall immediately void any warranty granted by ST for the ST product or service described herein and shall not create or extend in any manner whatsoever, any liability of ST.

ST and the ST logo are trademarks or registered trademarks of ST in various countries.

Information in this document supersedes and replaces all information previously supplied.

The ST logo is a registered trademark of STMicroelectronics. All other names are the property of their respective owners.

© 2010 STMicroelectronics - All rights reserved

STMicroelectronics group of companies

Australia - Belgium - Brazil - Canada - China - Czech Republic - Finland - France - Germany - Hong Kong - India - Israel - Italy - Japan - Malaysia - Malta - Morocco - Philippines - Singapore - Spain - Sweden - Switzerland - United Kingdom - United States of America

[www.st.com](http://www.st.com)

