



Dual Operational Amplifier and Voltage Reference

OPERATIONAL AMPLIFIER

- **LOW INPUT OFFSET VOLTAGE** : 0.5mV typ.
- **LOW SUPPLY CURRENT** : 350 μ A/op. (@ $V_{CC} = 5V$)
- **MEDIUM BANDWIDTH** (unity gain) : 0.9MHz
- **LARGE OUTPUT VOLTAGE SWING** : 0V to ($V_{CC} - 1.5V$)
- **INPUT COMMON MODE VOLTAGE RANGE INCLUDES GROUND**
- **WIDE POWER SUPPLY RANGE** : 3 to 32V ± 1.5 TO $\pm 16V$
- **1.5kV ESD PROTECTION**
- **VOLTAGE REFERENCE**
- **FIXED OUTPUT VOLTAGE REFERENCE 2.5V**
- **$\pm 0.4\%$ OR $\pm 0.7\%$ VOLTAGE PRECISION**
- **SINK CURRENT CAPABILITY** : 1 to 100mA
- **TYPICAL OUTPUT IMPEDANCE** : 0.2 Ω

DESCRIPTION

The TSM103W is a monolithic IC that includes one independent op-amp and another op-amp for which the non-inverting input is wired to a 2.5V fixed Voltage Reference. This device offers both space and cost savings in many applications such as power supply management or data acquisition systems.

ORDER CODE

Part Number	Temperature Range	Package	Packaging
TSM103WID	-40, +105°C	SO-8	Tube
TSM103WIDT			Tape & Reel
TSM103WAID			Tube
TSM103WAIDT			Tape & Reel

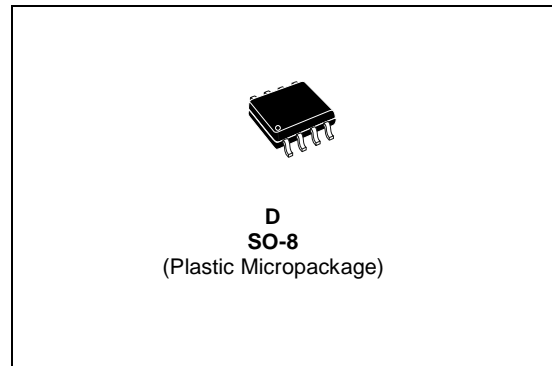

PIN CONNECTIONS (top view)

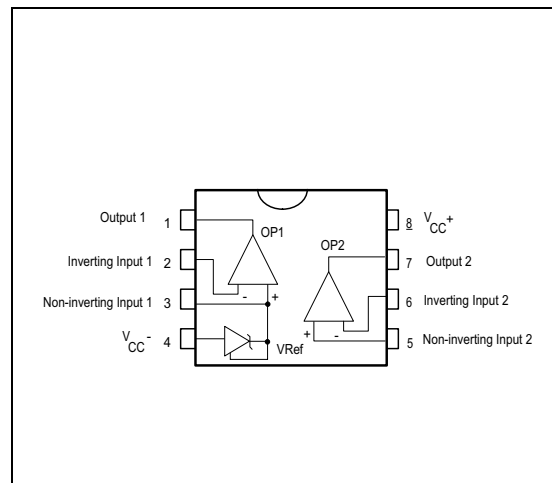

1 ABSOLUTE MAXIMUM RATINGS

Symbol	Parameter	Value	Unit
V_{CC}	Supply Voltage	36	V
V_{id}	Differential Input Voltage	$V_{CC} + 0.6$	V
V_i	Input VoltageL	-0.3 to $V_{CC} + 0.3V$	V
T_{stg}	Storage temperature range	-65 to + 150	°C
I_k	Continuous cathode current range	-100 to 150	mA
T_j	Maximum Junction Temperature	150	°C
R_{thja}	Thermal Resistance Junction to Ambient (SO package)	175	°C/W
T_l	Maximum Lead Temperature (10 seconds maximum)	260	°C
ESD	Electrostatic Discharge Protection	1.5	kV

OPERATING CONDITIONS

Symbol	Parameter	Value	Unit
V_{CC}	DC Supply Conditions	3 to 32	V
I_k	Vref Cathode Current	1 to 100	mA
T_{oper}	Operating Free-air Temperature Range	-40°C, +105°C	°C

2 ELECTRICAL CHARACTERISTICS

Symbol	Parameter	Min.	Typ.	Max.	Unit
I_{CC}	Total Supply Current, excluding Current in the Voltage Reference V _{CC+} = 5V, no load T _{min.} < T _{amb} < T _{max.} V _{CC+} = 30V, no load T _{min.} < T _{amb} < T _{max.}		0.7	1.2 2	mA

OPERATOR 2 (independent op-amp)

V_{CC+} = +5V, V_{CC} = Ground, V_o = 1.4V, T_{amb} = 25°C (unless otherwise specified)

Symbol	Parameter	Min.	Typ.	Max.	Unit
V_{io}	Input Offset Voltage V _{icm} = 0V TSM103WA, T _{amb} = 25° T _{min.} ≤ T _{amb} ≤ T _{max.} TSM103W, T _{amb} = 25° T _{min.} ≤ T _{amb} ≤ T _{max.}		0.5 1	2 3 4 5	mV
DV _{io}	Input Offset Voltage Drift		7		μV/°C
I_{io}	Input Offset Current T _{min.} ≤ T _{amb} ≤ T _{max.}		2	75 150	nA
I_{ib}	Input Bias Current T _{min.} ≤ T _{amb} ≤ T _{max.}		20	150 200	nA
A _{vd}	Large Signal Voltage Gain V _{CC} = 15V, R _L = 2k, V _o = 1.4V to 11.4V T _{min.} ≤ T _{amb} ≤ T _{max.}	50 25	100		V/mV
SVR	Supply Voltage Rejection Ratio V _{CC} = 5V to 30V	65	100		dB
V _{icm}	Input Common Mode Voltage Range V _{CC} = +30V - see note ¹ T _{min.} ≤ T _{amb} ≤ T _{max.}	0 0		(V _{CC+}) -1.5 (V _{CC+}) -2	V
CMR	Common Mode Rejection Ratio T _{min.} ≤ T _{amb} ≤ T _{max.}	70 60	85		dB
I_{source}	Output Current Source V _{CC} = +15V, V _o = 2V, V _{id} = +1V	20	40		mA
I_o	Short Circuit to Ground V _{CC} = +15V		40	60	mA
I_{sink}	Output Current Sink V _{id} = -1V, V _{CC} = +15V, V _o = 2V V _{CC} = +15V, V _o = 0.2V	10 12	20 50		mA μA
V _{OH}	High Level Output Voltage V _{CC+} = 30V T _{amb} = 25°C, R _L = 2k T _{min.} ≤ T _{amb} ≤ T _{max.} T _{amb} = 25°C, R _L = 10k T _{min.} ≤ T _{amb} ≤ T _{max.}	26 26 27 27	27 28		V
V _{OL}	Low Level Output Voltage R _L = 10k T _{min.} ≤ T _{amb} ≤ T _{max.}		5	20 20	mV
SR	Slew Rate at Unity Gain V _i = 0.5 to 3V, V _{CC} = 15V R _L = 2k, C _L = 100pF, unity gain	0.2	0.4		V/μs

Symbol	Parameter	Min.	Typ.	Max.	Unit
GBP	Gain Bandwidth Product $V_{CC} = 30V, R_L = 2k, C_L = 100pF$ $f = 100kHz, V_{in} = 10mV$	0.5	0.9		MHz
THD	Total Harmonic Distortion $f = 1kHz$ $A_V = 20dB, R_L = 2k, V_{CC} = 30V$ $C_L = 100pF, V_o = 2V_{pp}$		0.02		%
e_n	Equivalent Input Noise Voltage $f = 1kHz, R_s = 100\Omega$ $V_{CC} = 30V$		50		nV/ \sqrt{Hz}

1) The input common-mode voltage of either input signal voltage should not be allowed to go negative by more than 0.3V. The upper end of the common-mode voltage range is $V_{CC}^+ - 1.5V$. Both inputs can go to $V_{CC} + 0.3V$ without damage.

OPERATOR 1 (op-amp with non-inverting input connected to the internal Vref)

$V_{CC}^+ = +5V, V_{CC}^- = \text{Ground}, T_{amb} = 25^\circ C$ (unless otherwise specified)

Symbol	Parameter	Min.	Typ.	Max.	Unit
V_{io}	Input Offset Voltage $V_{icm} = 0V$ TSM103WA, $T_{amb} = 25^\circ$ $T_{min.} \leq T_{amb} \leq T_{max.}$ TSM103W, $T_{amb} = 25^\circ$ $T_{min.} \leq T_{amb} \leq T_{max.}$		0.5 1	2 3 4 5	mV
DV_{io}	Input Offset Voltage Drift		7		$\mu V/^\circ C$
I_{ib}	Input Bias Current negative input		20		nA
Avd	Large Signal Voltage Gain $V_{CC} = 15V, R_L = 2k, V_o = 1.4V$ to 11.4V $T_{min.} \leq T_{amb} \leq T_{max.}$		100		V/mV
SVR	Supply Voltage Rejection Ratio $V_{icm} = 0V$ $V_{CC}^+ = 5V$ to 30V	65	100		dB
I_{source}	Output Current Source $V_o = 2V$ $V_{CC} = +15V, V_{id} = +1V$	20	40		mA
I_o	Short Circuit to Ground $V_{CC} = +15V$		40	60	mA
I_{sink}	Output Current Sink $V_{id} = -1V,$ $V_{CC} = +15V, V_o = 2V$ $V_{CC} = +15V, V_o = 0.2V$	10 12	20 50		mA μA
V_{OH}	High Level Output Voltage $V_{CC}^+ = 30V$ $T_{amb} = 25^\circ C, R_L = 2k$ $T_{min.} \leq T_{amb} \leq T_{max.}$ $T_{amb} = 25^\circ C, R_L = 10k$ $T_{min.} \leq T_{amb} \leq T_{max.}$	26 26 27 27	27 28		V
V_{OL}	Low Level Output Voltage $R_L = 10k$ $T_{min.} \leq T_{amb} \leq T_{max.}$		5	20 20	mV
SR	Slew Rate at Unity Gain $V_i = 0.5$ to 2V, $V_{CC} = 15V$ $R_L = 2k, C_L = 100pF, \text{unity gain}$	0.2	0.4		V/ μs

Symbol	Parameter	Min.	Typ.	Max.	Unit
GBP	Gain Bandwidth Product $V_{CC} = 30V, R_L = 2k, C_L = 100pF$ $f = 100kHz, V_{in} = 10mV$	0.5	0.9		MHz
THD	Total Harmonic Distortion $f = 1kHz$ $A_V = 20dB, R_L = 2k, V_{CC} = 30V$ $C_L = 100pF, V_o = 2V_{pp}$		0.02		%

VOLTAGE REFERENCE

Symbol	Parameter	Min.	Typ.	Max.	Unit
V_{ref}	Reference Input Voltage, $I_k=10mA$ TSM103WA $\pm 0.4\%$ $T_{amb} = 25^\circ C$ $T_{min.} \leq T_{amb} \leq T_{max.}$ TSM103W $\pm 0.7\%$ $T_{amb} = 25^\circ C$ $T_{min.} \leq T_{amb} \leq T_{max.}$	2.49 2.48 2.482 2.465	2.5 2.500	2.51 2.52 2.518 2.535	V
ΔV_{ref}	Reference Input Voltage Deviation Over Temperature Range $V_{KA} = V_{ref}, I_k = 10mA$ $T_{min.} \leq T_{amb} \leq T_{max.}$		7	30	mV
I_{min}	Minimum Cathode Current for Regulation $V_{KA} = V_{ref}$		0.5	1	mA
$ Z_{KA} $	Dynamic Impedance - note ¹ $V_{KA} = V_{ref}, \Delta I_K = 1 \text{ to } 100mA, f < 1kHz$		0.2	0.5	Ω

1) The dynamic impedance is defined as $[Z_{KA}] = \Delta V_{KA} / \Delta I_K$

PACKAGE MECHANICAL DATA

SO-8 MECHANICAL DATA

DIM.	mm.			inch		
	MIN.	TYP	MAX.	MIN.	TYP.	MAX.
A	1.35		1.75	0.053		0.069
A1	0.10		0.25	0.04		0.010
A2	1.10		1.65	0.043		0.065
B	0.33		0.51	0.013		0.020
C	0.19		0.25	0.007		0.010
D	4.80		5.00	0.189		0.197
E	3.80		4.00	0.150		0.157
e		1.27			0.050	
H	5.80		6.20	0.228		0.244
h	0.25		0.50	0.010		0.020
L	0.40		1.27	0.016		0.050
k	8° (max.)					
ddd			0.1			0.04

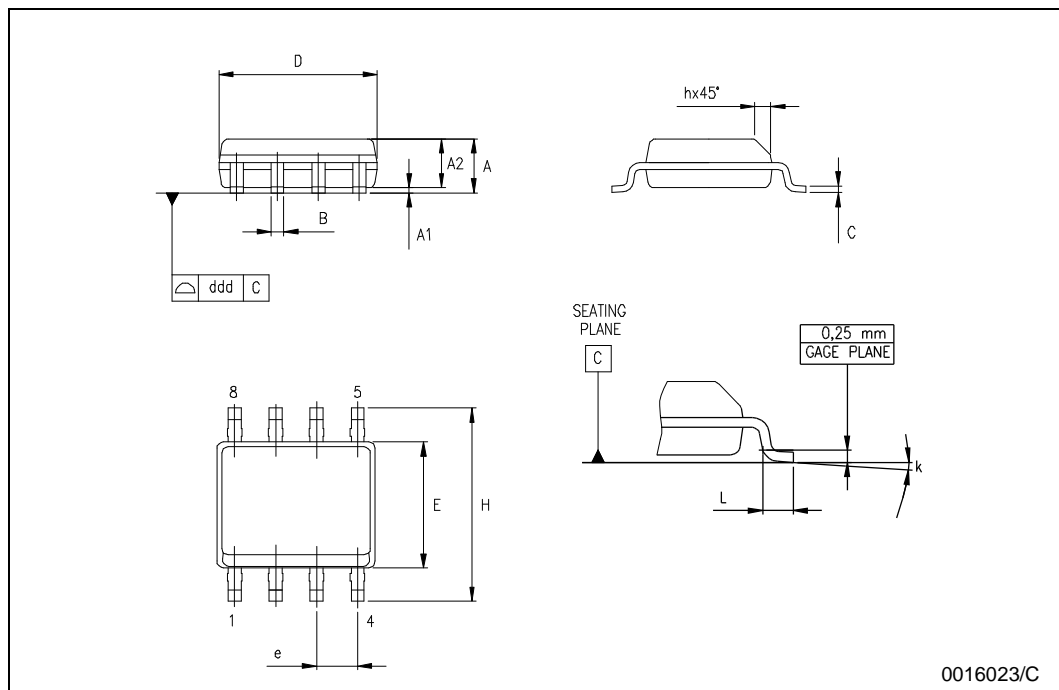

3 SUMMARY OF CHANGES

Date	Revision	Description of Changes
	1-2	First Release
02-April-2004	3	1 - Vid=Vcc+0.6 modified on AMR table - page 2 2 - Add Ik parameter on AMR table - page 2 3 - Avd test condition equal on both tables Operator 1 & Operator 2 - pages 3 & 4

Information furnished is believed to be accurate and reliable. However, STMicroelectronics assumes no responsibility for the consequences of use of such information nor for any infringement of patents or other rights of third parties which may result from its use. No license is granted by implication or otherwise under any patent or patent rights of STMicroelectronics. Specifications mentioned in this publication are subject to change without notice. This publication supersedes and replaces all information previously supplied. STMicroelectronics products are not authorized for use as critical components in life support devices or systems without express written approval of STMicroelectronics.

The ST logo is a registered trademark of STMicroelectronics
All other names are the property of their respective owners

© 2004 STMicroelectronics - All Rights Reserved

STMicroelectronics GROUP OF COMPANIES

Australia - Belgium - Brazil - Canada - China - Czech Republic - Finland - France - Germany - Hong Kong - India - Israel - Italy - Japan
Malaysia - Malta - Morocco - Singapore - Spain - Sweden - Switzerland - United Kingdom - United States
www.st.com

