



# STM8L151C2/K2/G2/F2 STM8L151C3/K3/G3/F3

8-bit ultralow power MCU, up to 8 KB Flash, up to 256 B data EEPROM, RTC, timers, USART, I2C, SPI, ADC, comparators

## Features

- Operating conditions
  - Operating power supply: 1.65 to 3.6 V (without BOR), 1.8 to 3.6 V (with BOR)
  - Temperature range: -40 to 85 or 125 °C
- Low power features
  - 5 low power modes: Wait, Low power run, Low power wait, Active-halt with RTC, Halt
  - Ultralow leakage per I/O: 50 nA
  - Fast wakeup from Halt: 5 µs
- Advanced STM8 core
  - Harvard architecture and 3-stage pipeline
  - Max freq: 16 MHz, 16 CISC MIPS peak
  - Up to 40 external interrupt sources
- Reset and supply management
  - Low power, ultrasafe BOR reset with 5 selectable thresholds
  - Ultralow power POR/PDR
  - Programmable voltage detector (PVD)
- Clock management
  - 32 kHz and 1-16 MHz crystal oscillators
  - Internal 16 MHz factory-trimmed RC
  - Internal 38 kHz low consumption RC
  - Clock security system
- Low power RTC
  - BCD calendar with alarm interrupt
  - Digital calibration with +/- 0.5 ppm accuracy
  - LSE security system
  - Auto-wakeup from Halt w/ periodic interrupt
- Memories
  - Up to 8 Kbytes of Flash program memory plus 256 bytes of data EEPROM with ECC
  - Flexible write/read protection modes
  - 1 Kbyte of RAM

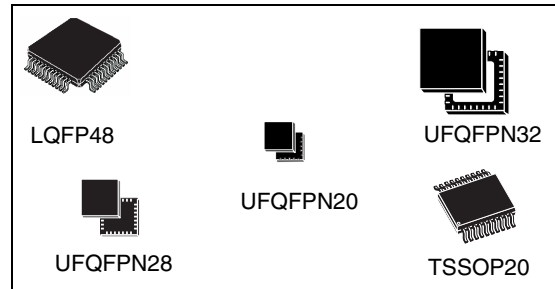

- DMA
  - 4 channels supporting ADC, SPI, I<sup>2</sup>C, USART, timers
  - 1 channel for memory-to-memory
- 12-bit ADC up to 1 Msps/28 channels
  - Temp. sensor and internal ref. voltage
- 2 ultralow power comparators
  - 1 with fixed threshold and 1 rail to rail
  - Wakeup capability
- Timers
  - Two 16-bit timers with 2 channels (IC, OC, PWM), quadrature encoder (TIM2, TIM3)
  - One 8-bit timer with 7-bit prescaler (TIM4)
  - 1 Window and 1 independent watchdog
  - Beeper timer with 1, 2 or 4 kHz frequencies
- Communication interfaces
  - One synchronous serial interface (SPI)
  - Fast I<sup>2</sup>C 400 kHz
  - One USART
- Up to 41 I/Os, all mappable on interrupt vectors
- Up to 20 capacitive sensing channels supporting touchkey, proximity touch, linear touch, and rotary touch sensors
- Development support
  - Fast on-chip programming and non-intrusive debugging with SWIM
  - Bootloader using USART
- 96-bit unique ID

# Contents

<b>1</b>	<b>Introduction</b>	<b>9</b>
<b>2</b>	<b>Description</b>	<b>11</b>
2.1	Device overview	12
2.2	Ultralow power continuum	13
<b>3</b>	<b>Functional overview</b>	<b>14</b>
3.1	Low power modes	15
3.2	Central processing unit STM8	15
3.2.1	Advanced STM8 Core	15
3.2.2	Interrupt controller	16
3.3	Reset and supply management	17
3.3.1	Power supply scheme	17
3.3.2	Power supply supervisor	17
3.3.3	Voltage regulator	17
3.4	Clock management	18
3.5	Low power real-time clock	19
3.6	Memories	20
3.7	DMA	20
3.8	Analog-to-digital converter	20
3.9	Ultralow power comparators	20
3.10	System configuration controller and routing interface	21
3.11	Touchsensing	21
3.12	Timers	21
3.12.1	16-bit general purpose timers	22
3.12.2	8-bit basic timer	22
3.13	Watchdog timers	22
3.13.1	Window watchdog timer	22
3.13.2	Independent watchdog timer	22
3.14	Beeper	22
3.15	Communication interfaces	23
3.15.1	SPI	23

3.15.2	I <sup>2</sup> C	23
3.15.3	USART	23
3.16	Infrared (IR) interface	23
3.17	Development support	24
<b>4</b>	<b>Pin description</b>	<b>25</b>
4.1	System configuration options	30
<b>5</b>	<b>Memory and register map</b>	<b>31</b>
5.1	Memory mapping	31
5.2	Register map	32
<b>6</b>	<b>Interrupt vector mapping</b>	<b>47</b>
<b>7</b>	<b>Electrical parameters</b>	<b>49</b>
7.1	Parameter conditions	49
7.1.1	Minimum and maximum values	49
7.1.2	Typical values	49
7.1.3	Typical curves	49
7.1.4	Loading capacitor	49
7.1.5	Pin input voltage	50
7.2	Absolute maximum ratings	50
7.3	Operating conditions	52
7.3.1	General operating conditions	52
7.3.2	Embedded reset and power control block characteristics	53
7.3.3	Supply current characteristics	54
7.3.4	Clock and timing characteristics	65
7.3.5	Memory characteristics	71
7.3.6	I/O current injection characteristics	72
7.3.7	I/O port pin characteristics	72
7.3.8	Communication interfaces	80
7.3.9	Embedded reference voltage	85
7.3.10	Temperature sensor	86
7.3.11	Comparator characteristics	86
7.3.12	12-bit ADC1 characteristics	88
7.3.13	EMC characteristics	93

---

7.4	Thermal characteristics .....	96
<b>8</b>	<b>Option bytes .....</b>	<b>97</b>
<b>9</b>	<b>Unique ID .....</b>	<b>100</b>
<b>10</b>	<b>Package characteristics .....</b>	<b>101</b>
10.1	ECOPACK .....	101
10.2	Package mechanical data .....	102
<b>11</b>	<b>Device ordering information .....</b>	<b>109</b>
<b>12</b>	<b>Revision history .....</b>	<b>110</b>

## List of tables

Table 1.	Low density STM8L15xxx low power device features and peripheral counts . . . . .	12
Table 2.	Timer feature comparison . . . . .	21
Table 3.	Legend/abbreviation for table 4 . . . . .	27
Table 4.	Low density STM8L15xxx pin description . . . . .	27
Table 5.	Flash and RAM boundary addresses . . . . .	32
Table 6.	Factory conversion registers . . . . .	32
Table 7.	I/O port hardware register map . . . . .	32
Table 8.	General hardware register map . . . . .	33
Table 9.	CPU/SWIM/debug module/interrupt controller registers . . . . .	45
Table 10.	Interrupt mapping . . . . .	47
Table 11.	Voltage characteristics . . . . .	50
Table 12.	Current characteristics . . . . .	51
Table 13.	Thermal characteristics . . . . .	51
Table 14.	General operating conditions . . . . .	52
Table 15.	Embedded reset and power control block characteristics . . . . .	53
Table 16.	Total current consumption in Run mode . . . . .	55
Table 17.	Total current consumption in Wait mode . . . . .	57
Table 18.	Total current consumption and timing in Low power run mode at VDD = 1.65 V to 3.6 V . . . . .	59
Table 19.	Total current consumption in Low power wait mode at VDD = 1.65 V to 3.6 V . . . . .	61
Table 20.	Total current consumption and timing in Active-halt mode at VDD = 1.65 V to 3.6 V . . . . .	62
Table 21.	Typical current consumption in Active-halt mode, RTC clocked by LSE external crystal . . . . .	62
Table 22.	Total current consumption and timing in Halt mode at VDD = 1.65 to 3.6 V . . . . .	63
Table 23.	Peripheral current consumption . . . . .	64
Table 24.	Current consumption under external reset . . . . .	65
Table 25.	HSE external clock characteristics . . . . .	65
Table 26.	LSE external clock characteristics . . . . .	65
Table 27.	HSE oscillator characteristics . . . . .	66
Table 28.	LSE oscillator characteristics . . . . .	67
Table 29.	HSI oscillator characteristics . . . . .	68
Table 30.	LSI oscillator characteristics . . . . .	69
Table 31.	RAM and hardware registers . . . . .	71
Table 32.	Flash program and data EEPROM memory . . . . .	71
Table 33.	I/O current injection susceptibility . . . . .	72
Table 34.	I/O static characteristics . . . . .	73
Table 35.	Output driving current (high sink ports) . . . . .	76
Table 36.	Output driving current (true open drain ports) . . . . .	76
Table 37.	Output driving current (PA0 with high sink LED driver capability) . . . . .	76
Table 38.	NRST pin characteristics . . . . .	78
Table 39.	SPI1 characteristics . . . . .	80
Table 40.	I2C characteristics . . . . .	83
Table 41.	Reference voltage characteristics . . . . .	85
Table 42.	TS characteristics . . . . .	86
Table 43.	Comparator 1 characteristics . . . . .	86
Table 44.	Comparator 2 characteristics . . . . .	87
Table 45.	ADC1 characteristics . . . . .	88
Table 46.	ADC1 accuracy with VDDA = 3.3 V to 2.5 V . . . . .	90
Table 47.	ADC1 accuracy with VDDA = 2.4 V to 3.6 V . . . . .	90

Table 48.	ADC1 accuracy with $V_{DDA} = V_{REF+} = 1.8 \text{ V to } 2.4 \text{ V}$ . . . . .	90
Table 49.	$R_{AIN}$ max for $f_{ADC} = 16 \text{ MHz}$ . . . . .	93
Table 50.	EMS data . . . . .	94
Table 51.	EMI data . . . . .	94
Table 52.	ESD absolute maximum ratings . . . . .	95
Table 53.	Electrical sensitivities . . . . .	95
Table 54.	Thermal characteristics. . . . .	96
Table 55.	Option byte addresses . . . . .	97
Table 56.	Option byte description . . . . .	98
Table 57.	Unique ID registers (96 bits) . . . . .	100
Table 58.	LQFP48 – 48-pin low profile quad flat package (7x7), package mechanical data . . . . .	102
Table 59.	UFQFPN32 - 32-lead ultra thin fine pitch quad flat no-lead package (5 x 5), package mechanical data . . . . .	103
Table 60.	UFQFPN28 – 28-lead ultra thin fine pitch quad flat no-lead package (4 x 4), package mechanical data . . . . .	105
Table 61.	UFQFPN20 - 20-lead ultra thin fine pitch quad flat package (3x3) package mechanical data . . . . .	107
Table 62.	TSSOP20 - 20-pin thin shrink small outline package mechanical data . . . . .	108

## List of figures

Figure 1.	Low density STM8L151xx device block diagram	14
Figure 2.	Low density STM8L15x clock tree diagram	19
Figure 3.	STM8L151Cx LQFP48 package pinout	25
Figure 4.	STM8L151Kx UFQFPN32 package pinout	25
Figure 5.	STM8L151Gx UFQFPN28 package pinout	25
Figure 6.	STM8L151Fx UFQFPN20 package pinout	26
Figure 7.	STM8L151Fx TSSOP20 package pinout	26
Figure 8.	Memory map	31
Figure 9.	Pin loading conditions	49
Figure 10.	Pin input voltage	50
Figure 11.	POR/BOR thresholds	54
Figure 12.	Typ. $I_{DD}(RUN)$ vs. $V_{DD}$ , $f_{CPU} = 16$ MHz	56
Figure 13.	Typ. $I_{DD}(Wait)$ vs. $V_{DD}$ , $f_{CPU} = 16$ MHz 1)	58
Figure 14.	Typ. $I_{DD}(LPR)$ vs. $V_{DD}$ (LSI clock source)	60
Figure 15.	Typ. $I_{DD}(LPW)$ vs. $V_{DD}$ (LSI clock source)	61
Figure 16.	HSE oscillator circuit diagram	66
Figure 17.	LSE oscillator circuit diagram	67
Figure 18.	Typical HSI frequency vs $V_{DD}$	69
Figure 19.	Typical LSI frequency vs. $V_{DD}$	70
Figure 20.	Typical $V_{IL}$ and $V_{IH}$ vs $V_{DD}$ (high sink I/Os)	74
Figure 21.	Typical $V_{IL}$ and $V_{IH}$ vs $V_{DD}$ (true open drain I/Os)	74
Figure 22.	Typical pull-up resistance $R_{PU}$ vs $V_{DD}$ with $V_{IN}=V_{SS}$	75
Figure 23.	Typical pull-up current $I_{PU}$ vs $V_{DD}$ with $V_{IN}=V_{SS}$	75
Figure 24.	Typ. $V_{OL}$ @ $V_{DD} = 3.0$ V (high sink ports)	77
Figure 25.	Typ. $V_{OL}$ @ $V_{DD} = 1.8$ V (high sink ports)	77
Figure 26.	Typ. $V_{OL}$ @ $V_{DD} = 3.0$ V (true open drain ports)	77
Figure 27.	Typ. $V_{OL}$ @ $V_{DD} = 1.8$ V (true open drain ports)	77
Figure 28.	Typ. $V_{DD} - V_{OH}$ @ $V_{DD} = 3.0$ V (high sink ports)	77
Figure 29.	Typ. $V_{DD} - V_{OH}$ @ $V_{DD} = 1.8$ V (high sink ports)	77
Figure 30.	Typical NRST pull-up resistance $R_{PU}$ vs $V_{DD}$	78
Figure 31.	Typical NRST pull-up current $I_{PU}$ vs $V_{DD}$	79
Figure 32.	Recommended NRST pin configuration	79
Figure 33.	SPI1 timing diagram - slave mode and $CPHA=0$	81
Figure 34.	SPI1 timing diagram - slave mode and $CPHA=1^{(1)}$	81
Figure 35.	SPI1 timing diagram - master mode <sup>(1)</sup>	82
Figure 36.	Typical application with I2C bus and timing diagram 1)	84
Figure 37.	ADC1 accuracy characteristics	91
Figure 38.	Typical connection diagram using the ADC1	91
Figure 39.	Power supply and reference decoupling ( $V_{REF+}$ not connected to $V_{DDA}$ )	92
Figure 40.	Power supply and reference decoupling ( $V_{REF+}$ connected to $V_{DDA}$ )	92
Figure 41.	Max. dynamic current consumption on $V_{REF+}$ supply pin during ADC conversion	93
Figure 42.	LQFP48 – 48-pin low profile quad flat package outline (7x7)	102
Figure 43.	UFQFPN32 - 32-lead ultra thin fine pitch quad flat no-lead package outline (5 x 5)	103
Figure 44.	UFQFPN32 recommended footprint <sup>(1)</sup>	103
Figure 45.	UFQFPN28 – 28-lead ultra thin fine pitch quad flat no-lead package outline (4 x 4)	104
Figure 46.	UFQFPN28 recommended footprint (dimensions in mm)	105
Figure 47.	UFQFPN20 - 20-lead ultra thin fine pitch quad flat package outline (3x3)	106

---

Figure 48. UFQFPN20 recommended footprint (dimensions in mm) . . . . .	106
Figure 49. TSSOP20 - 20-pin thin shrink small outline package . . . . .	108
Figure 50. Low density STM8L15xxx ordering information scheme . . . . .	109



# 1 Introduction

This document describes the features, pinout, mechanical data and ordering information for the Low density STM8L15xxx devices: STM8L151x2 and STM8L151x3 microcontrollers with a Flash memory density of up to 8 Kbytes.

For further details on the STMicroelectronics Ultralow power family please refer to [Section 2.2: Ultralow power continuum on page 13](#).

For detailed information on device operation and registers, refer to the reference manual (RM0031).

For information on to the Flash program memory and data EEPROM, refer to the programming manual (PM0054).

For information on the debug module and SWIM (single wire interface module), refer to the STM8 SWIM communication protocol and debug module user manual (UM0470).

For information on the STM8 core, refer to the STM8 CPU programming manual (PM0044).

Low density devices provide the following benefits:

- Integrated system
  - Up to 8 Kbytes of low-density embedded Flash program memory
  - 256 bytes of data EEPROM
  - 1 Kbyte of RAM
  - Internal high-speed and low-power low speed RC.
  - Embedded reset
- Ultralow power consumption
  - 1  $\mu$ A in Active-halt mode
  - Clock gated system and optimized power management
  - Capability to execute from RAM for Low power wait mode and Low power run mode
- Advanced features
  - Up to 16 MIPS at 16 MHz CPU clock frequency
  - Direct memory access (DMA) for memory-to-memory or peripheral-to-memory access.
- Short development cycles
  - Application scalability across a common family product architecture with compatible pinout, memory map and modular peripherals.
  - Wide choice of development tools

STM8L Ultralow power microcontrollers can operate either from 1.8 to 3.6 V (down to 1.65 V at power-down) or from 1.65 to 3.6 V. They are available in the -40 to +85 °C and -40 to +125 °C temperature ranges.

These features make the STM8L Ultralow power microcontroller families suitable for a wide range of applications:

- Medical and handheld equipment
- Application control and user interface
- PC peripherals, gaming, GPS and sport equipment
- Alarm systems, wired and wireless sensors
- Metering

The devices are offered in five different packages from 20 to 48 pins. Different sets of peripherals are included depending on the device. Refer to [Section 3](#) for an overview of the complete range of peripherals proposed in this family.

All STM8L Ultralow power products are based on the same architecture with the same memory mapping and a coherent pinout.

[Figure 1](#) shows the block diagram of the STM8L Low density family.

## 2 Description

The Low density STM8L15xxx Ultralow power devices feature an enhanced STM8 CPU core providing increased processing power (up to 16 MIPS at 16 MHz) while maintaining the advantages of a CISC architecture with improved code density, a 24-bit linear addressing space and an optimized architecture for low power operations.

The family includes an integrated debug module with a hardware interface (SWIM) which allows non-intrusive in-application debugging and ultrafast Flash programming.

All Low density STM8L15xxx microcontrollers feature embedded data EEPROM and low power low-voltage single-supply program Flash memory.

The devices incorporate an extensive range of enhanced I/Os and peripherals, a 12-bit ADC, two comparators, a real-time clock, two 16-bit timers, one 8-bit timer, as well as standard communication interfaces such as an SPI, an I<sup>2</sup>C interface, and one USART. The modular design of the peripheral set allows the same peripherals to be found in different ST microcontroller families including 32-bit families. This makes any transition to a different family very easy, and simplified even more by the use of a common set of development tools.

## 2.1 Device overview

**Table 1. Low density STM8L15xxx low power device features and peripheral counts**

Features		STM8L151F3	STM8L151G3	STM8L151K3/ STM8L151C3	STM8L151F2	STM8L151G2	STM8L151K2/ STM8L151C2
Flash (Kbytes)		8			4		
Data EEPROM (bytes)		256					
RAM (Kbytes)		1					
Timers	Basic	1 (8-bit)					
	General purpose	2 (16-bit)					
Communication interfaces	SPI	1					
	I2C	1					
	USART	1					
GPIOs		18 <sup>(1)</sup>	26 <sup>(1)</sup>	30 <sup>(2)</sup> /41 <sup>(1)(2)</sup>	18 <sup>(1)</sup>	26 <sup>(1)</sup>	30 <sup>(2)</sup> /41 <sup>(1)(2)</sup>
12-bit synchronized ADC (number of channels)		1 (10)	1 (18)	1 (23/28) <sup>(3)</sup>	1 (10)	1 (18)	1 (23/28) <sup>(3)</sup>
Comparators (COMP1/COMP2)		2					
Others		RTC, window watchdog, independent watchdog, 16-MHz and 38-kHz internal RC, 1- to 16-MHz and 32-kHz external oscillator					
CPU frequency		16 MHz					
Operating voltage		1.8 to 3.6 V (down to 1.65 V at power-down) with BOR 1.65 to 3.6 V without BOR					
Operating temperature		-40 to +85 °C / -40 to +125 °C					
Packages		TSSOP20 UFQFPN20	UFQFPN28	UFQFPN32 LQFP48	TSSOP20 UFQFPN20	UFQFPN28	UFQFPN32 LQFP48

1. The number of GPIOs given in this table includes the NRST/PA1 pin but the application can use the NRST/PA1 pin as general purpose output only (PA1).
2. 26 GPIOs in the STM8L151K3 and 40 GPIOs in the STM8L151C3.
3. 22 channels in the STM8L151K3 and 28 channels in the STM8L151C3.

## 2.2 Ultralow power continuum

The Ultralow power Low density STM8L15xxx devices are fully pin-to-pin, software and feature compatible. Besides the full compatibility within the family, the devices are part of STMicroelectronics microcontrollers UltraLowPower strategy which also includes STM8L101xx and STM32L15xxx. The STM8L and STM32L families allow a continuum of performance, peripherals, system architecture, and features.

They are all based on STMicroelectronics 0.13  $\mu\text{m}$  ultralow leakage process.

*Note: 1 The STM8L151xx and STM8L152xx are pin-to-pin compatible with STM8L101xx devices.*

### Performance

All families incorporate highly energy-efficient cores with both Harvard architecture and pipelined execution: advanced STM8 core for STM8L families and ARM Cortex™-M3 core for STM32L family. In addition specific care for the design architecture has been taken to optimize the mA/DMIPS and mA/MHz ratios.

This allows the Ultralow power performance to range from 5 up to 33.3 DMIPs.

### Shared peripherals

STM8L151xx/152xx and STM32L15xx share identical peripherals which ensure a very easy migration from one family to another:

- Analog peripherals: ADC1 and comparators COMP1/COMP2
- Digital peripherals: RTC and some communication interfaces

### Common system strategy

To offer flexibility and optimize performance, the STM8L151xx/152xx and STM32L15xx devices use a common architecture:

- Same power supply range from 1.8 to 3.6 V, down to 1.65 V at power down
- Architecture optimized to reach ultralow consumption both in low power modes and Run mode
- Fast startup strategy from low power modes
- Flexible system clock
- Ultrasafe reset: same reset strategy for both STM8L15x and STM32L15xxx including power-on reset, power-down reset, brownout reset and programmable voltage detector.

### Features

ST UltraLowPower continuum also lies in feature compatibility:

- More than 10 packages with pin count from 20 to 100 pins and size down to 3 x 3 mm
- Memory density ranging from 4 to 128 Kbytes

### 3 Functional overview

Figure 1. Low density STM8L151xx device block diagram

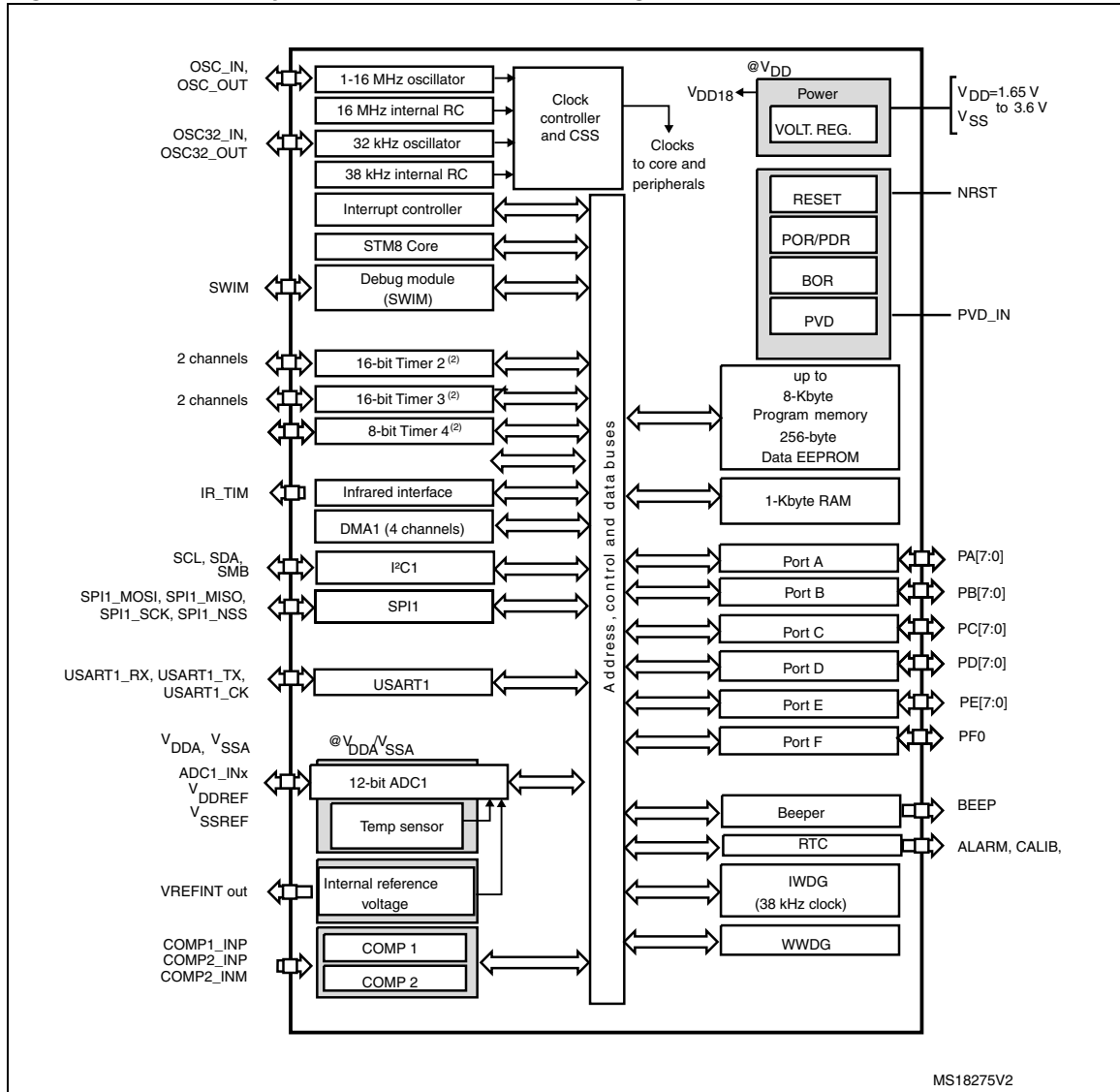

1. **Legend:**  
 ADC: Analog-to-digital converter  
 BOR: Brownout reset  
 DMA: Direct memory access  
 I2C: Inter-integrated circuit multimaster interface  
 IWDG: Independent watchdog  
 POR/PDR: Power on reset / power down reset  
 RTC: Real-time clock  
 SPI: Serial peripheral interface  
 SWIM: Single wire interface module  
 USART: Universal synchronous asynchronous receiver transmitter  
 WWDG: Window watchdog

2. There is no TIM1 on STM8L151x2, STM8L151x3 devices.

## 3.1 Low power modes

The Low density STM8L15x devices support five low power modes to achieve the best compromise between low power consumption, short startup time and available wakeup sources:

- **Wait mode:** The CPU clock is stopped, but selected peripherals keep running. An internal or external interrupt or a Reset can be used to exit the microcontroller from Wait mode (WFE or WFI mode). Wait consumption: refer to [Table 17](#).
- **Low power run mode:** The CPU and the selected peripherals are running. Execution is done from RAM with a low speed oscillator (LSI or LSE). Flash and data EEPROM are stopped and the voltage regulator is configured in Ultralow power mode. The microcontroller enters Low power run mode by software and can exit from this mode by software or by a reset.  
All interrupts must be masked. They cannot be used to exit the microcontroller from this mode. Low power run mode consumption: refer to [Table 18](#).
- **Low power wait mode:** This mode is entered when executing a Wait for event in Low power run mode. It is similar to Low power run mode except that the CPU clock is stopped. The wakeup from this mode is triggered by a Reset or by an internal or external event (peripheral event generated by the timers, serial interfaces, DMA controller (DMA1), comparators and I/O ports). When the wakeup is triggered by an event, the system goes back to Low power run mode.  
All interrupts must be masked. They cannot be used to exit the microcontroller from this mode. Low power wait mode consumption: refer to [Table 19](#).
- **Active-halt mode:** CPU and peripheral clocks are stopped, except RTC. The wakeup can be triggered by RTC interrupts, external interrupts or reset. Active-halt consumption: refer to [Table 20](#) and [Table 21](#).
- **Halt mode:** CPU and peripheral clocks are stopped, the device remains powered on. The RAM content is preserved. The wakeup is triggered by an external interrupt or reset. A few peripherals have also a wakeup from Halt capability. Switching off the internal reference voltage reduces power consumption. Through software configuration it is also possible to wake up the device without waiting for the internal reference voltage wakeup time to have a fast wakeup time of 5  $\mu$ s. Halt consumption: refer to [Table 22](#).

## 3.2 Central processing unit STM8

### 3.2.1 Advanced STM8 Core

The 8-bit STM8 core is designed for code efficiency and performance with an Harvard architecture and a 3-stage pipeline.

It contains 6 internal registers which are directly addressable in each execution context, 20 addressing modes including indexed indirect and relative addressing, and 80 instructions.

### Architecture and registers

- Harvard architecture
- 3-stage pipeline
- 32-bit wide program memory bus - single cycle fetching most instructions
- X and Y 16-bit index registers - enabling indexed addressing modes with or without offset and read-modify-write type data manipulations
- 8-bit accumulator
- 24-bit program counter - 16 Mbyte linear memory space
- 16-bit stack pointer - access to a 64 Kbyte level stack
- 8-bit condition code register - 7 condition flags for the result of the last instruction

### Addressing

- 20 addressing modes
- Indexed indirect addressing mode for lookup tables located anywhere in the address space
- Stack pointer relative addressing mode for local variables and parameter passing

### Instruction set

- 80 instructions with 2-byte average instruction size
- Standard data movement and logic/arithmetic functions
- 8-bit by 8-bit multiplication
- 16-bit by 8-bit and 16-bit by 16-bit division
- Bit manipulation
- Data transfer between stack and accumulator (push/pop) with direct stack access
- Data transfer using the X and Y registers or direct memory-to-memory transfers

## 3.2.2 Interrupt controller

The Low density STM8L15x features a nested vectored interrupt controller:

- Nested interrupts with 3 software priority levels
- 32 interrupt vectors with hardware priority
- Up to 40 external interrupt sources on 11 vectors
- Trap and reset interrupts



## 3.3 Reset and supply management

### 3.3.1 Power supply scheme

The device requires a 1.65 V to 3.6 V operating supply voltage ( $V_{DD}$ ). The external power supply pins must be connected as follows:

- $V_{SS1}$  ;  $V_{DD1}$  = 1.8 to 3.6 V, down to 1.65 V at power down: external power supply for I/Os and for the internal regulator. Provided externally through  $V_{DD1}$  pins, the corresponding ground pin is  $V_{SS1}$ .
- $V_{SSA}$  ;  $V_{DDA}$  = 1.8 to 3.6 V, down to 1.65 V at power down: external power supplies for analog peripherals (minimum voltage to be applied to  $V_{DDA}$  is 1.8 V when the ADC1 is used).  $V_{DDA}$  and  $V_{SSA}$  must be connected to  $V_{DD1}$  and  $V_{SS1}$ , respectively.
- $V_{SS2}$  ;  $V_{DD2}$  = 1.8 to 3.6 V, down to 1.65 V at power down: external power supplies for I/Os.  $V_{DD2}$  and  $V_{SS2}$  must be connected to  $V_{DD1}$  and  $V_{SS1}$ , respectively.
- $V_{REF+}$  ;  $V_{REF-}$  (for ADC1): external reference voltage for ADC1. Must be provided externally through  $V_{REF+}$  and  $V_{REF-}$  pin.

### 3.3.2 Power supply supervisor

The device has an integrated ZEROPOWER power-on reset (POR)/power-down reset (PDR), coupled with a brownout reset (BOR) circuitry. At power-on, BOR is always active, and ensures proper operation starting from 1.8 V. After the 1.8 V BOR threshold is reached, the option byte loading process starts, either to confirm or modify default thresholds, or to disable BOR permanently (in which case, the  $V_{DD}$  min value at power down is 1.65 V).

Five BOR thresholds are available through option bytes, starting from 1.8 V to 3 V. To reduce the power consumption in Halt mode, it is possible to automatically switch off the internal reference voltage (and consequently the BOR) in Halt mode. The device remains under reset when  $V_{DD}$  is below a specified threshold,  $V_{POR/PDR}$  or  $V_{BOR}$ , without the need for any external reset circuit.

The device features an embedded programmable voltage detector (PVD) that monitors the  $V_{DD}/V_{DDA}$  power supply and compares it to the  $V_{PVD}$  threshold. This PVD offers 7 different levels between 1.85 V and 3.05 V, chosen by software, with a step around 200 mV. An interrupt can be generated when  $V_{DD}/V_{DDA}$  drops below the  $V_{PVD}$  threshold and/or when  $V_{DD}/V_{DDA}$  is higher than the  $V_{PVD}$  threshold. The interrupt service routine can then generate a warning message and/or put the MCU into a safe state. The PVD is enabled by software.

### 3.3.3 Voltage regulator

The Low density STM8L15x embeds an internal voltage regulator for generating the 1.8 V power supply for the core and peripherals.

This regulator has two different modes:

- Main voltage regulator mode (MVR) for Run, Wait for interrupt (WFI) and Wait for event (WFE) modes.
- Low power voltage regulator mode (LPVR) for Halt, Active-halt, Low power run and Low power wait modes.

When entering Halt or Active-halt modes, the system automatically switches from the MVR to the LPVR in order to reduce current consumption.

## 3.4 Clock management

The clock controller distributes the system clock (SYSCLK) coming from different oscillators to the core and the peripherals. It also manages clock gating for low power modes and ensures clock robustness.

### Features

- **Clock prescaler:** to get the best compromise between speed and current consumption the clock frequency to the CPU and peripherals can be adjusted by a programmable prescaler
- **Safe clock switching:** Clock sources can be changed safely on the fly in run mode through a configuration register.
- **Clock management:** To reduce power consumption, the clock controller can stop the clock to the core, individual peripherals or memory.
- **System clock sources:** 4 different clock sources can be used to drive the system clock:
  - 1-16 MHz High speed external crystal (HSE)
  - 16 MHz High speed internal RC oscillator (HSI)
  - 32.768 kHz Low speed external crystal (LSE)
  - 38 kHz Low speed internal RC (LSI)
- **RTC clock sources:** the above four sources can be chosen to clock the RTC whatever the system clock.
- **Startup clock:** After reset, the microcontroller restarts by default with an internal 2 MHz clock (HSI/8). The prescaler ratio and clock source can be changed by the application program as soon as the code execution starts.
- **Clock security system (CSS):** This feature can be enabled by software. If a HSE clock failure occurs, the system clock is automatically switched to HSI.
- **Configurable main clock output (CCO):** This outputs an external clock for use by the application.

Figure 2. Low density STM8L15x clock tree diagram

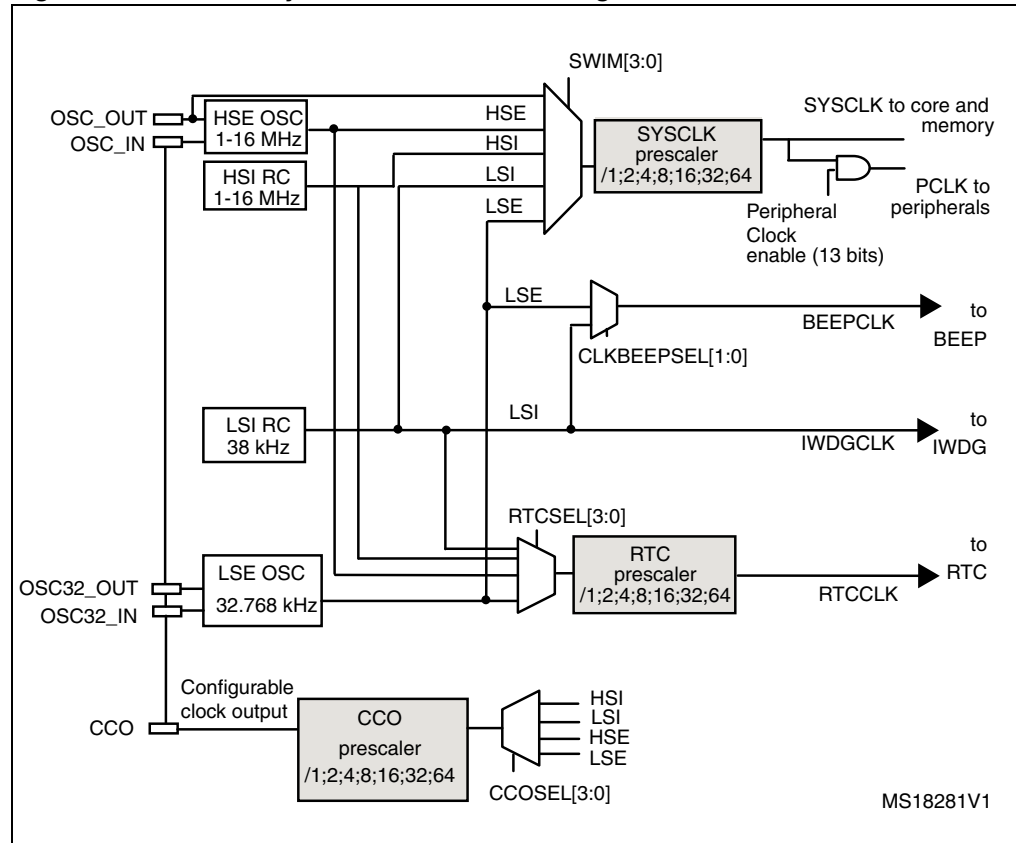

### 3.5 Low power real-time clock

The real-time clock (RTC) is an independent binary coded decimal (BCD) timer/counter.

Six byte locations contain the second, minute, hour (12/24 hour), week day, date, month, year, in BCD (binary coded decimal) format. Correction for 28, 29 (leap year), 30, and 31 day months are made automatically.

It provides a programmable alarm and programmable periodic interrupts with wakeup from Halt capability.

- Periodic wakeup time using the 32.768 kHz LSE with the lowest resolution (of 61  $\mu$ s) is from min. 122  $\mu$ s to max. 3.9 s. With a different resolution, the wakeup time can reach 36 hours
- Periodic alarms based on the calendar can also be generated from every second to every year

### 3.6 Memories

The Low density STM8L15x devices have the following main features:

- Up to 1 Kbyte of RAM
- The non-volatile memory is divided into three arrays:
  - Up to 8 Kbytes of low-density embedded Flash program memory
  - 256 bytes of data EEPROM
  - Option bytes.

The EEPROM embeds the error correction code (ECC) feature.

The option byte protects part of the Flash program memory from write and readout piracy.

### 3.7 DMA

A 4-channel direct memory access controller (DMA1) offers a memory-to-memory and peripherals-from/to-memory transfer capability. The 4 channels are shared between the following IPs with DMA capability: ADC1, I2C1, SPI1, USART1, the three Timers.

### 3.8 Analog-to-digital converter

- 12-bit analog-to-digital converter (ADC1) with 25 channels (including 1 fast channel), temperature sensor and internal reference voltage
- Conversion time down to 1  $\mu$ s with  $f_{\text{SYSCLK}} = 16$  MHz
- Programmable resolution
- Programmable sampling time
- Single and continuous mode of conversion
- Scan capability: automatic conversion performed on a selected group of analog inputs
- Analog watchdog
- Triggered by timer

*Note:* ADC1 can be served by DMA1.

### 3.9 Ultralow power comparators

The Low density STM8L15x embeds two comparators (COMP1 and COMP2) sharing the same current bias and voltage reference. The voltage reference can be internal or external (coming from an I/O).

- One comparator with fixed threshold (COMP1).
- One comparator rail to rail with fast or slow mode (COMP2). The threshold can be one of the following:
  - External I/O
  - Internal reference voltage or internal reference voltage submultiple (1/4, 1/2, 3/4)

The two comparators can be used together to offer a window function. They can wake up from Halt mode.

### 3.10 System configuration controller and routing interface

The system configuration controller provides the capability to remap some alternate functions on different I/O ports. TIM4 and ADC1 DMA channels can also be remapped.

The highly flexible routing interface controls the routing of internal analog signals to ADC1, COMP1, COMP2, and the internal reference voltage  $V_{REFINT}$ . It also provides a set of registers for efficiently managing the charge transfer acquisition sequence ([Section 3.11: Touchsensing](#)).

### 3.11 Touchsensing

Low density STM8L15xxx devices provide a simple solution for adding capacitive sensing functionality to any application. Capacitive sensing technology is able to detect finger presence near an electrode which is protected from direct touch by a dielectric (example, glass, plastic). The capacitive variation introduced by a finger (or any conductive object) is measured using a proven implementation based on a surface charge transfer acquisition principle. It consists of charging the electrode capacitance and then transferring a part of the accumulated charges into a sampling capacitor until the voltage across this capacitor has reached a specific threshold. In Low density STM8L15xxx devices, the acquisition sequence is managed either by software or by hardware and it involves analog I/O groups, the routing interface, and timers. Reliable touch sensing solutions can be quickly and easily implemented using the free STM8 Touch Sensing Library.

### 3.12 Timers

Low density STM8L15x devices contain two 16-bit general purpose timers (TIM2 and TIM3) and one 8-bit basic timer (TIM4).

All the timers can be served by DMA1.

[Table 2](#) compares the features of the advanced control, general-purpose and basic timers.

**Table 2. Timer feature comparison**

Timer	Counter resolution	Counter type	Prescaler factor	DMA1 request generation	Capture/compare channels	Complementary outputs
TIM2	16-bit	up/down	Any power of 2 from 1 to 128	Yes	2	None
TIM3					0	
TIM4	8-bit	up	Any power of 2 from 1 to 32768			

### 3.12.1 16-bit general purpose timers

- 16-bit autoreload (AR) up/down-counter
- 7-bit prescaler adjustable to fixed power of 2 ratios (1...128)
- 2 individually configurable capture/compare channels
- PWM mode
- Interrupt capability on various events (capture, compare, overflow, break, trigger)
- Synchronization with other timers or external signals (external clock, reset, trigger and enable)

### 3.12.2 8-bit basic timer

The 8-bit timer consists of an 8-bit up auto-reload counter driven by a programmable prescaler. It can be used for timebase generation with interrupt generation on timer overflow.

## 3.13 Watchdog timers

The watchdog system is based on two independent timers providing maximum security to the applications.

### 3.13.1 Window watchdog timer

The window watchdog (WWDG) is used to detect the occurrence of a software fault, usually generated by external interferences or by unexpected logical conditions, which cause the application program to abandon its normal sequence.

### 3.13.2 Independent watchdog timer

The independent watchdog peripheral (IWDG) can be used to resolve processor malfunctions due to hardware or software failures.

It is clocked by the internal LSI RC clock source, and thus stays active even in case of a CPU clock failure.

## 3.14 Beeper

The beeper function outputs a signal on the BEEP pin for sound generation. The signal is in the range of 1, 2 or 4 kHz.

## 3.15 Communication interfaces

### 3.15.1 SPI

The serial peripheral interface (SPI1) provides half/ full duplex synchronous serial communication with external devices.

- Maximum speed: 8 Mbit/s ( $f_{\text{SYSCLK}}/2$ ) both for master and slave
- Full duplex synchronous transfers
- Simplex synchronous transfers on 2 lines with a possible bidirectional data line
- Master or slave operation - selectable by hardware or software
- Hardware CRC calculation
- Slave/master selection input pin

*Note:* SPI1 can be served by the DMA1 Controller.

### 3.15.2 I<sup>2</sup>C

The I<sup>2</sup>C bus interface (I<sup>2</sup>C1) provides multi-master capability, and controls all I<sup>2</sup>C bus-specific sequencing, protocol, arbitration and timing.

- Master, slave and multi-master capability
- Standard mode up to 100 kHz and fast speed modes up to 400 kHz.
- 7-bit and 10-bit addressing modes.
- SMBus 2.0 and PMBus support
- Hardware CRC calculation

*Note:* I<sup>2</sup>C1 can be served by the DMA1 Controller.

### 3.15.3 USART

The USART interface (USART1) allows full duplex, asynchronous communications with external devices requiring an industry standard NRZ asynchronous serial data format. It offers a very wide range of baud rates.

- 1 Mbit/s full duplex SCI
- SPI1 emulation
- High precision baud rate generator
- Smartcard emulation
- IrDA SIR encoder decoder
- Single wire half duplex mode

*Note:* USART1 can be served by the DMA1 Controller.

## 3.16 Infrared (IR) interface

The Low density STM8L15x devices contain an infrared interface which can be used with an IR LED for remote control functions. Two timer output compare channels are used to generate the infrared remote control signals.

## 3.17 Development support

### Development tools

Development tools for the STM8 microcontrollers include:

- The STIce emulation system offering tracing and code profiling
- The STVD high-level language debugger including C compiler, assembler and integrated development environment
- The STVP Flash programming software

The STM8 also comes with starter kits, evaluation boards and low-cost in-circuit debugging/programming tools.

### Single wire data interface (SWIM) and debug module

The debug module with its single wire data interface (SWIM) permits non-intrusive real-time in-circuit debugging and fast memory programming.

The Single wire interface is used for direct access to the debugging module and memory programming. The interface can be activated in all device operation modes.

The non-intrusive debugging module features a performance close to a full-featured emulator. Beside memory and peripherals, CPU operation can also be monitored in real-time by means of shadow registers.

### Bootloader

The Low density STM8L15xxx Ultralow power devices feature a built-in bootloader (see *UM0560: STM8 bootloader user manual*).

The bootloader is used to download application software into the device memories, including RAM, program and data memory, using standard serial interfaces. It is a complementary solution to programming via the SWIM debugging interface.



## 4 Pin description

Figure 3. STM8L151Cx LQFP48 package pinout

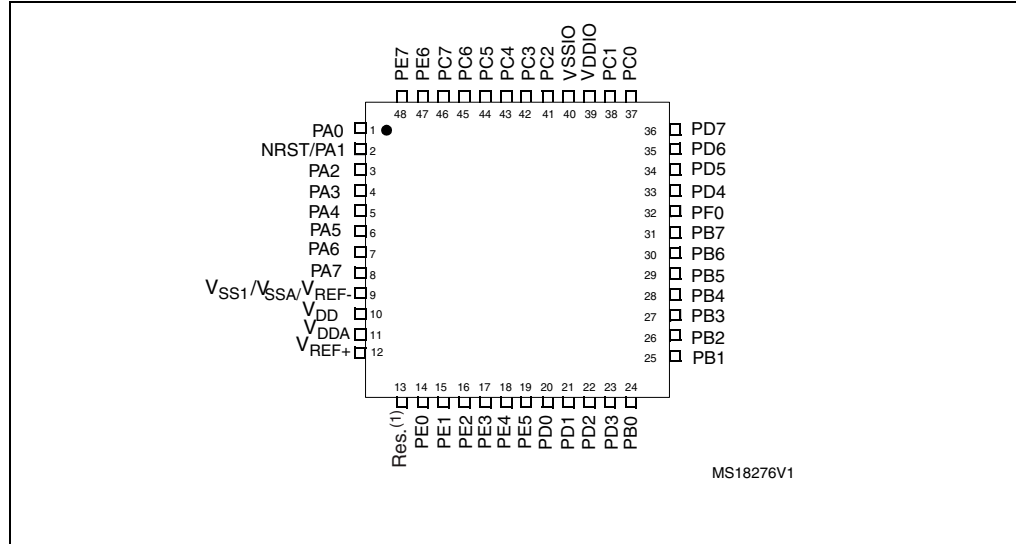

Figure 4. STM8L151Kx UFQFPN32 package pinout

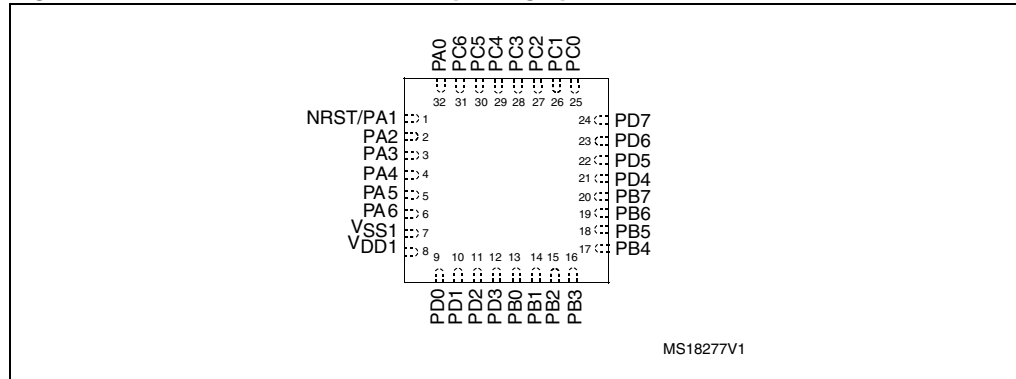

Figure 5. STM8L151Gx UFQFPN28 package pinout

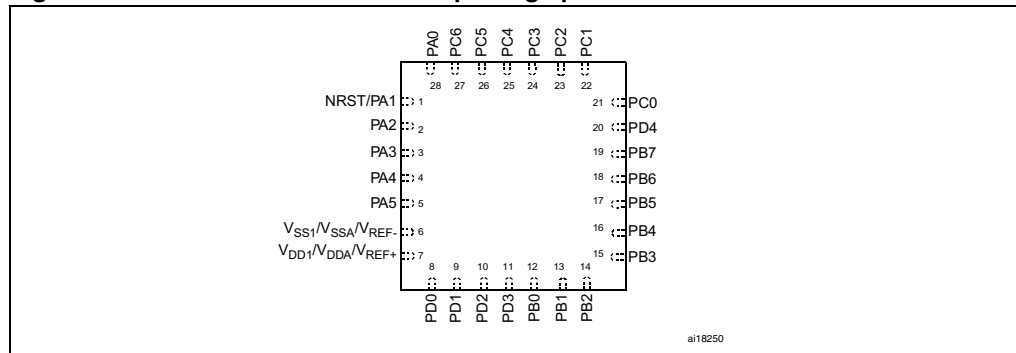

Figure 6. STM8L151Fx UFQFPN20 package pinout

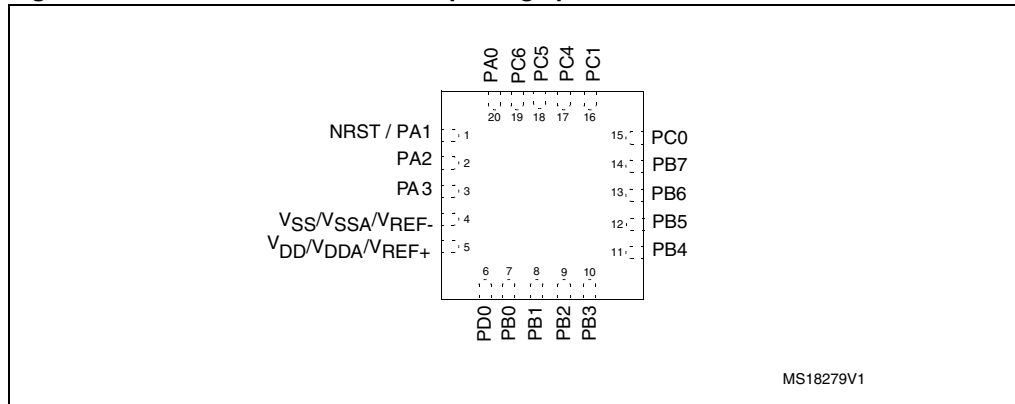

Figure 7. STM8L151Fx TSSOP20 package pinout

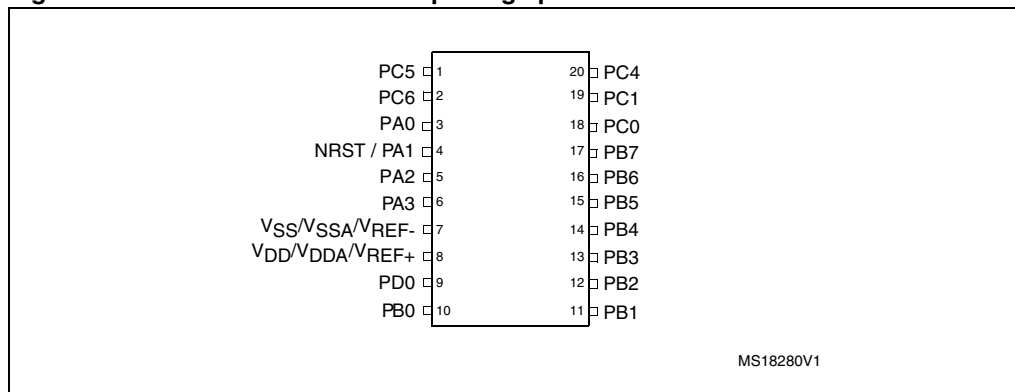

Table 3. Legend/abbreviation for table 4

<b>Type</b>	I= input, O = output, S = power supply	
<b>Level</b>	Output	HS = high sink/source (20 mA)
<b>Port and control configuration</b>	Input	float = floating, wpu = weak pull-up
	Output	T = true open drain, OD = open drain, PP = push pull
<b>Reset state</b>	Bold X (pin state after reset release). Unless otherwise specified, the pin state is the same during the reset phase (i.e. "under reset") and after internal reset release (i.e. at reset state).	

Table 4. Low density STM8L15xxx pin description

Pin number					Pin name	Type	Input			Output			Main function (after reset)	Default alternate function
LQFP48	UFQFPN32	UFQFPN28	UFQFPN20	TSSOP20			floating	wpu	Ext. interrupt	High sink/source	OD	PP		
2	1	1	1	4	NRST/PA1 <sup>(1)</sup>	I/O		X		HS		X	Reset	PA1
3	2	2	2	5	PA2/OSC_IN/ [USART_TX] <sup>(2)</sup> / [SPI_MISO] <sup>(2)</sup>	I/O	X	X	X	HS	X	X	Port A2	HSE oscillator input / [USART transmit] / [SPI master in- slave out] /
4	3	3	3	6	PA3/OSC_OUT/[USART_RX] <sup>(2)</sup> / [SPI_MOSI] <sup>(2)</sup>	I/O	X	X	X	HS	X	X	Port A3	HSE oscillator output / [USART receive] / [SPI master out/slave in]
5	4	4	-	-	PA4/TIM2_BKIN/ [TIM2_ETR] <sup>(2)</sup> / ADC1_IN2	I/O	X	X	X	HS	X	X	Port A4	Timer 2 - break input / [Timer 2 - external trigger] / ADC1 input 2
6	5	5	-	-	PA5/TIM3_BKIN/ [TIM3_ETR] <sup>(2)</sup> /ADC1_IN1	I/O	X	X	X	HS	X	X	Port A5	Timer 3 - break input / [Timer 3 - external trigger] / ADC1input 1
7	6	-	-	-	PA6/ADC1_TRIG/ ADC1_IN0	I/O	X	X	X	HS	X	X	Port A6	ADC1- trigger / ADC1input 0
8	-	-	-	-	PA7	I/O	X	X	X	HS	X	X	Port A7	
24	13	12	7	10	PB0 <sup>(3)</sup> /TIM2_CH1/ ADC1_IN18	I/O	X	X	X	HS	X	X	Port B0	Timer 2 - channel 1 / ADC1_IN18
25	14	13	8	11	PB1/TIM3_CH1/ ADC1_IN17	I/O	X	X	X	HS	X	X	Port B1	Timer 3 - channel 1 / ADC1_IN17
26	15	14	9	12	PB2/ TIM2_CH2/ ADC1_IN16	I/O	X	X	X	HS	X	X	Port B2	Timer 2 - channel 2 ADC1_IN16
27	16	15	10	13	PB3/TIM2_ETR/ ADC1_IN15/RTC_ALAR M <sup>(4)</sup>	I/O	X	X	X	HS	X	X	Port B3	Timer 2 - external trigger / ADC1_IN15 / RTC_ALARM <sup>(4)</sup>
28	17	16	11	14	PB4 <sup>(3)</sup> /SPI1_NSS/ ADC1_IN14	I/O	X	X	X	HS	X	X	Port B4	SPI master/slave select / ADC1_IN14

Table 4. Low density STM8L15xxx pin description (continued)

Pin number					Pin name	Type	Input			Output			Main function (after reset)	Default alternate function
LQFP48	UFQFPN32	UFQFPN28	UFQFPN20	TSSOP20			floating	wpu	Ext. interrupt	High sink/source	OD	PP		
29	18	17	12	15	PB5/SPI_SCK/ /ADC1_IN13	I/O	X	X	X	HS	X	X	Port B5	[SPI clock] / ADC1_IN13
30	19	18	13	16	PB6/SPI1_MOSI/ ADC1_IN12	I/O	X	X	X	HS	X	X	Port B6	SPI master out/ slave in / ADC1_IN12
31	20	19	14	17	PB7/SPI1_MISO/ ADC1_IN11	I/O	X	X	X	HS	X	X	Port B7	SPI1 master in- slave out/ ADC1_IN11
37	25	21	15	18	PC0/I2C_SDA	I/O	X		X		T <sup>(5)</sup>		Port C0	I2C data
38	26	22	16	19	PC1/I2C_SCL	I/O	X		X		T <sup>(3)</sup>		Port C1	I2C clock
41	27	23	-	-	PC2/USART_RX/ADC1_I N6	I/O	X	X	X	HS	X	X	Port C2	USART receive / ADC1_IN6
42	28	24	-	-	PC3/USART_TX/ ADC1_IN5	I/O	X	X	X	HS	X	X	Port C3	USART transmit / ADC1_IN5
43	29	25	17	20	PC4/USART_CK]/ I2C_SMB/CCO/ ADC1_IN4	I/O	X	X	X	HS	X	X	Port C4	USART synchronous clock / I2C1_SMB / Configurable clock output / ADC1_IN4
44	30	26	18	1	PC5/OSC32_IN /[SPI1_NSS] <sup>(2)</sup> / [USART_TX] <sup>(2)</sup> / TIM2_CH1 <sup>(6)</sup>	I/O	X	X	X	HS	X	X	Port C5	LSE oscillator input / [SPI master/slave select] / [USART transmit]/ Timer 2 -channel 1 <sup>(6)</sup>
45	31	27	19	2	PC6/OSC32_OUT/ [SPI_SCK] <sup>(2)</sup> / [USART_RX] <sup>(2)</sup> / TIM2_CH2 <sup>(6)</sup>	I/O	X	X	X	HS	X	X	Port C6	LSE oscillator output / [SPI clock] / [USART receive]/ Timer 2 -channel 2 <sup>(6)</sup>
46	-	-	-	-	PC7/ADC1_IN3	I/O	X	X	X	HS	X	X	Port C7	ADC1_IN3
20	9	8	6	9	PD0/TIM3_CH2/ [ADC1_TRIG] <sup>(2)</sup> / ADC1_IN22	I/O	X	X	X	HS	X	X	Port D0	Timer 3 - channel 2 / [ADC1_Trigger]/ ADC1_IN22
21	10	9	-	-	PD1/TIM3_ETR/ ADC1_IN21	I/O	X	X	X	HS	X	X	Port D1	Timer 3 - external trigger / ADC1_IN21
22	11	10	-	-	PD2/ ADC1_IN20	I/O	X	X	X	HS	X	X	Port D2	ADC1_IN20
23	12	11	-	-	PD3/ ADC1_IN19/ RTC_CALIB <sup>(7)</sup>	I/O	X	X	X	HS	X	X	Port D3	ADC1_IN19/ RTC calibration <sup>(7)</sup>

Table 4. Low density STM8L15xxx pin description (continued)

Pin number					Pin name	Type	Input			Output			Main function (after reset)	Default alternate function
LQFP48	UFQFPN32	UFQFPN28	UFQFPN20	TSSOP20			floating	wpu	Ext. interrupt	High sink/source	OD	PP		
33	21	20	-	-	PD4/ ADC1_IN10	I/O	X	X	X	HS	X	X	Port D4	ADC1_IN10
34	22	-	-	-	PD5/ ADC1_IN9	I/O	X	X	X	HS	X	X	Port D5	ADC1_IN9
-	23	-	-	-	PD6/ ADC1_IN8/RTC_CALIB	I/O	X	X	X	HS	X	X	Port D6	ADC1_IN8 / RTC calibration
36	24	-	-	-	PD7/ ADC1_IN7/RTC_ALARM	I/O	X	X	X	HS	X	X	Port D7	ADC1_IN7 / RTC alarm
14	-	-	-	-	PE0	I/O	X	X	X	HS	X	X	Port E0	
15	-	-	-	-	PE1	I/O	X	X	X	HS	X	X	Port E1	
16	-	-	-	-	PE2	I/O	X	X	X	HS	X	X	Port E2	
17	-	-	-	-	PE3/ADC1_IN26	I/O	X	X	X	HS	X	X	Port E3	ADC1_IN26
18	-	-	-	-	PE4/ADC1_IN27	I/O	X	X	X	HS	X	X	Port E4	ADC1_IN27
19	-	-	-	-	PE5/ADC1_IN23/ COMP_INP	I/O	X	X	X	HS	X	X	Port E5	ADC1_IN23/ Comparator positive input
47	-	-	-	-	PE6/PVD_IN	I/O	X	X	X	HS	X	X	Port E6	PVD_IN
48	-	-	-	-	PE7/ADC1_IN25	I/O	X	X	X	HS	X	X	Port E7	ADC1_IN25
32	-	-	-	-	PF0/ADC1_IN24	I/O	X	X	X	HS	X	X	Port F0	ADC1_IN24
10	-	-	-	-	V <sub>DD</sub>	S								Digital supply voltage
-	8	7	5	8	V <sub>DD</sub> /V <sub>DDA</sub> /V <sub>REF+</sub>	S								Digital supply voltage / ADC1 positive voltage reference
9	7	6	4	7	V <sub>SS</sub> /V <sub>REF-</sub> /V <sub>SSA</sub>									Ground voltage / ADC1 negative voltage reference / Analog ground voltage
11	-	-	-	-	V <sub>DDA</sub>	S								Analog supply voltage
12	-	-	-	-	V <sub>REF+</sub>	S								ADC1 positive voltage reference
1	32	28	20	3	PA0 <sup>(8)</sup> /[USART_CK] <sup>(2)</sup> / SWIM/BEEP/IR_TIM <sup>(9)</sup>	I/O	X	X	X	HS <sup>(9)</sup>	X	X	Port A0	[USART1 synchronous clock] <sup>(2)</sup> / SWIM input and output / Beep output / Infrared Timer output
40	-	-	-	-	V <sub>SSIO</sub>									I/O ground voltage
39	-	-	-	-	V <sub>DDIO</sub>									I/O supply voltage

1. At power-up, the PA1/NRST pin is a reset input pin with pull-up. To be used as a general purpose pin (PA1), it can be configured only as output open-drain or push-pull, not as a general purpose input. Refer to Section *Configuring NRST/PA1 pin as general purpose output* in the STM8L15xxx and STM8L16xxx reference manual (RM0031).
2. [ ] Alternate function remapping option (if the same alternate function is shown twice, it indicates an exclusive choice not a duplication of the function).
3. A pull-up is applied to PB0 and PB4 during the reset phase. These two pins are input floating after reset release.
4. 20-pin and 28-pin packages only.
5. In the open-drain output column, 'T' defines a true open-drain I/O (P-buffer and protection diode to V<sub>DD</sub> are not implemented).
6. 20-pin packages only.
7. 28-pin packages only.
8. The PA0 pin is in input pull-up during the reset phase and after reset release.
9. High Sink LED driver capability available on PA0.

*Note:* The slope control of all GPIO pins, except true open drain pins, can be programmed. By default, the slope control is limited to 2 MHz.

## 4.1 System configuration options

As shown in [Table 4: Low density STM8L15xxx pin description](#), some alternate functions can be remapped on different I/O ports by programming one of the two remapping registers described in the “Routing interface (RI) and system configuration controller” section in the STM8L15x and STM8L16x reference manual (RM0031).

# 5 Memory and register map

## 5.1 Memory mapping

The memory map is shown in [Figure 8](#).

**Figure 8. Memory map**

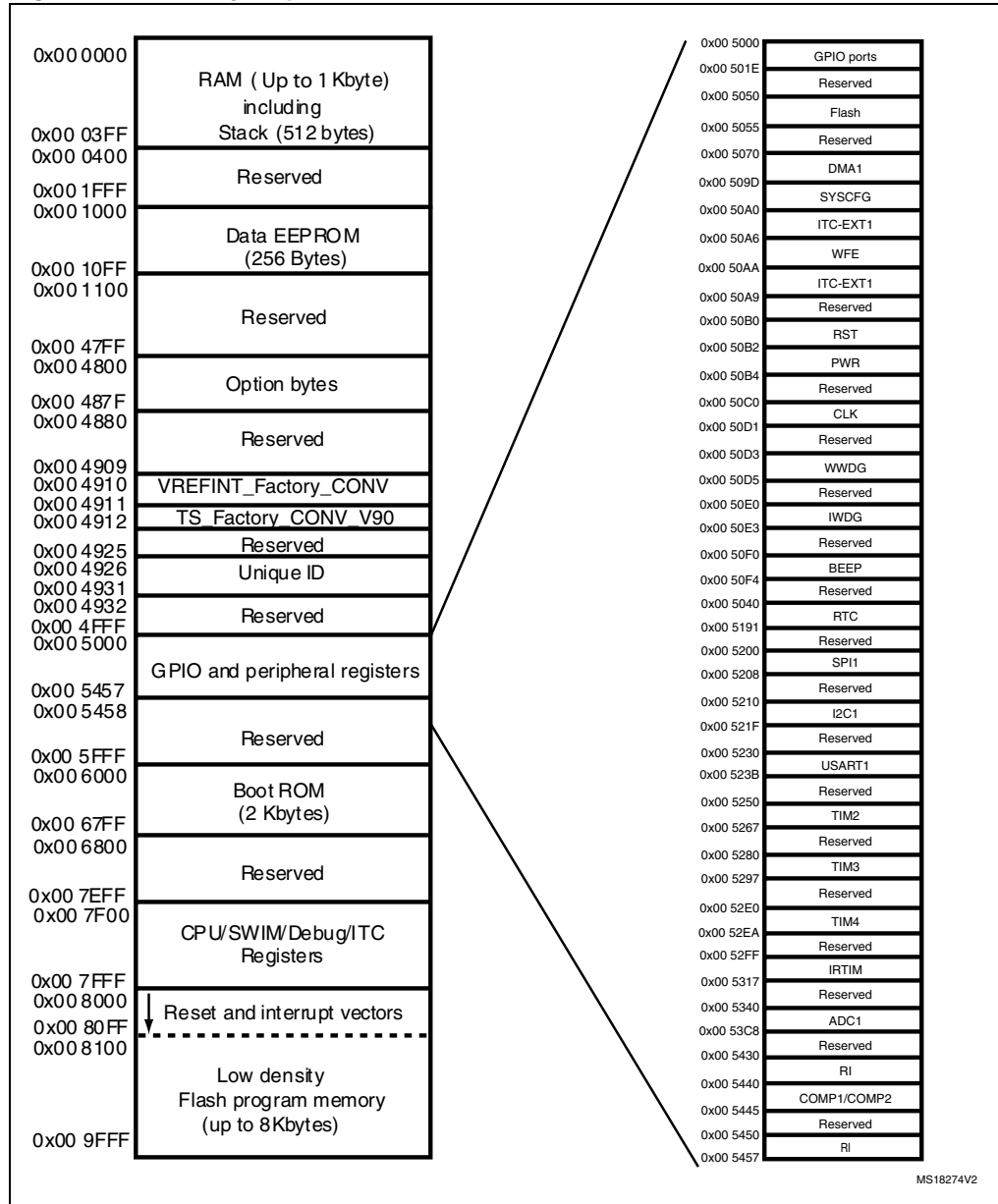

1. [Table 5](#) lists the boundary addresses for each memory size. The top of the stack is at the RAM end address.
2. The VREFINT\_Factory\_CONV byte represents the LSB of the  $V_{REFINT}$  12-bit ADC1 conversion result. The

MSB have a fixed value: 0x6.

3. The TS\_Factory\_CONV\_V90 byte represents the LSB of the V<sub>90</sub> 12-bit ADC1 conversion result. The MSB have a fixed value: 0x3.
4. Refer to [Table 8](#) for an overview of hardware register mapping, to [Table 7](#) for details on I/O port hardware registers, and to [Table 9](#) for information on CPU/SWIM/debug module controller registers.

**Table 5. Flash and RAM boundary addresses**

Memory area	Size	Start address	End address
RAM	1 Kbyte	0x00 0000	0x00 03FF
Flash program memory	8 Kbytes	0x00 8000	0x00 9FFF
	4 Kbytes	0x00 8000	0x00 8FFF

## 5.2 Register map

**Table 6. Factory conversion registers**

Address	Block	Register label	Register name	Reset status
0x00 4910	-	VREFINT_Factory_CONV	Value of the internal reference voltage measured during the factory phase	0xXX
0x00 4911	-	TS_Factory_CONV_V90	Value of the temperature sensor output voltage measured during the factory phase	0xXX

**Table 7. I/O port hardware register map**

Address	Block	Register label	Register name	Reset status
0x00 5000	Port A	PA_ODR	Port A data output latch register	0x00
0x00 5001		PA_IDR	Port A input pin value register	0xXX
0x00 5002		PA_DDR	Port A data direction register	0x00
0x00 5003		PA_CR1	Port A control register 1	0x01
0x00 5004		PA_CR2	Port A control register 2	0x00
0x00 5005	Port B	PB_ODR	Port B data output latch register	0x00
0x00 5006		PB_IDR	Port B input pin value register	0xXX
0x00 5007		PB_DDR	Port B data direction register	0x00
0x00 5008		PB_CR1	Port B control register 1	0x00
0x00 5009		PB_CR2	Port B control register 2	0x00



Table 7. I/O port hardware register map (continued)

Address	Block	Register label	Register name	Reset status
0x00 500A	Port C	PC_ODR	Port C data output latch register	0x00
0x00 500B		PC_IDR	Port C input pin value register	0xXX
0x00 500C		PC_DDR	Port C data direction register	0x00
0x00 500D		PC_CR1	Port C control register 1	0x00
0x00 500E		PC_CR2	Port C control register 2	0x00
0x00 500F	Port D	PD_ODR	Port D data output latch register	0x00
0x00 5010		PD_IDR	Port D input pin value register	0xXX
0x00 5011		PD_DDR	Port D data direction register	0x00
0x00 5012		PD_CR1	Port D control register 1	0x00
0x00 5013		PD_CR2	Port D control register 2	0x00
0x00 5014	Port E	PE_ODR	Port E data output latch register	0x00
0x00 5015		PE_IDR	Port E input pin value register	0xXX
0x00 5016		PE_DDR	Port E data direction register	0x00
0x00 5017		PE_CR1	Port E control register 1	0x00
0x00 5018		PE_CR2	Port E control register 2	0x00
0x00 5019	Port F	PF_ODR	Port F data output latch register	0x00
0x00 501A		PF_IDR	Port F input pin value register	0xXX
0x00 501B		PF_DDR	Port F data direction register	0x00
0x00 501C		PF_CR1	Port F control register 1	0x00
0x00 501D		PF_CR2	Port F control register 2	0x00

Table 8. General hardware register map

Address	Block	Register label	Register name	Reset status
0x00 502E to 0x00 5049	Reserved area (44 bytes)			
0x00 5050	Flash	FLASH_CR1	Flash control register 1	0x00
0x00 5051		FLASH_CR2	Flash control register 2	0x00
0x00 5052		FLASH_PUKR	Flash program memory unprotection key register	0x00
0x00 5053		FLASH_DUKR	Flash data EEPROM unprotection key register	0x00
0x00 5054		FLASH_IAPSR	Flash in-application programming status register	0x00

Table 8. General hardware register map (continued)

Address	Block	Register label	Register name	Reset status
0x00 5055 to 0x00 506F		Reserved area (27 bytes)		
0x00 5070	DMA1	DMA1_GCSR	DMA1 global configuration & status register	0xFC
0x00 5071		DMA1_GIR1	DMA1 global interrupt register 1	0x00
0x00 5072 to 0x00 5074		Reserved area (3 bytes)		
0x00 5075		DMA1_C0CR	DMA1 channel 0 configuration register	0x00
0x00 5076		DMA1_C0SPR	DMA1 channel 0 status & priority register	0x00
0x00 5077		DMA1_C0NDTR	DMA1 number of data to transfer register (channel 0)	0x00
0x00 5078		DMA1_C0PARH	DMA1 peripheral address high register (channel 0)	0x52
0x00 5079		DMA1_C0PARL	DMA1 peripheral address low register (channel 0)	0x00
0x00 507A		Reserved area (1 byte)		
0x00 507B		DMA1_C0M0ARH	DMA1 memory 0 address high register (channel 0)	0x00
0x00 507C		DMA1_C0M0ARL	DMA1 memory 0 address low register (channel 0)	0x00
0x00 507D to 0x00 507E		Reserved area (2 bytes)		
0x00 507F		DMA1_C1CR	DMA1 channel 1 configuration register	0x00
0x00 5080		DMA1_C1SPR	DMA1 channel 1 status & priority register	0x00
0x00 5081		DMA1_C1NDTR	DMA1 number of data to transfer register (channel 1)	0x00
0x00 5082		DMA1_C1PARH	DMA1 peripheral address high register (channel 1)	0x52
0x00 5083		DMA1_C1PARL	DMA1 peripheral address low register (channel 1)	0x00

Table 8. General hardware register map (continued)

Address	Block	Register label	Register name	Reset status
0x00 5084	DMA1	Reserved area (1 byte)		
0x00 5085		DMA1_C1M0ARH	DMA1 memory 0 address high register (channel 1)	0x00
0x00 5086		DMA1_C1M0ARL	DMA1 memory 0 address low register (channel 1)	0x00
0x00 5087 0x00 5088		Reserved area (2 bytes)		
0x00 5089		DMA1_C2CR	DMA1 channel 2 configuration register	0x00
0x00 508A		DMA1_C2SPR	DMA1 channel 2 status & priority register	0x00
0x00 508B		DMA1_C2NDTR	DMA1 number of data to transfer register (channel 2)	0x00
0x00 508C		DMA1_C2PARH	DMA1 peripheral address high register (channel 2)	0x52
0x00 508D		DMA1_C2PARL	DMA1 peripheral address low register (channel 2)	0x00
0x00 508E		Reserved area (1 byte)		
0x00 508F		DMA1_C2M0ARH	DMA1 memory 0 address high register (channel 2)	0x00
0x00 5090		DMA1_C2M0ARL	DMA1 memory 0 address low register (channel 2)	0x00
0x00 5091 0x00 5092		Reserved area (2 bytes)		
0x00 5093		DMA1_C3CR	DMA1 channel 3 configuration register	0x00
0x00 5094		DMA1_C3SPR	DMA1 channel 3 status & priority register	0x00
0x00 5095		DMA1_C3NDTR	DMA1 number of data to transfer register (channel 3)	0x00
0x00 5096		DMA1_C3PARH_C3M1ARH	DMA1 peripheral address high register (channel 3)	0x40
0x00 5097		DMA1_C3PARL_C3M1ARL	DMA1 peripheral address low register (channel 3)	0x00
0x00 5098		DMA_C3M0EAR	DMA channel 3 memory 0 extended address register	0x00
0x00 5099		DMA1_C3M0ARH	DMA1 memory 0 address high register (channel 3)	0x00
0x00 509A		DMA1_C3M0ARL	DMA1 memory 0 address low register (channel 3)	0x00
0x00 509B to 0x00 509C		Reserved area (3 bytes)		

Table 8. General hardware register map (continued)

Address	Block	Register label	Register name	Reset status
0x00 509D	SYSCFG	SYSCFG_RMPCR3	Remapping register 3	0x00
0x00 509E		SYSCFG_RMPCR1	Remapping register 1	0x00
0x00 509F		SYSCFG_RMPCR2	Remapping register 2	0x00
0x00 50A0	ITC - EXTI	EXTI_CR1	External interrupt control register 1	0x00
0x00 50A1		EXTI_CR2	External interrupt control register 2	0x00
0x00 50A2		EXTI_CR3	External interrupt control register 3	0x00
0x00 50A3		EXTI_SR1	External interrupt status register 1	0x00
0x00 50A4		EXTI_SR2	External interrupt status register 2	0x00
0x00 50A5		EXTI_CONF1	External interrupt port select register 1	0x00
0x00 50A6	WFE	WFE_CR1	WFE control register 1	0x00
0x00 50A7		WFE_CR2	WFE control register 2	0x00
0x00 50A8		WFE_CR3	WFE control register 3	0x00
0x00 50A9		WFE_CR4	WFE control register 4	0x00
0x00 50AA	ITC - EXTI	EXTI_CR4	External interrupt control register 4	0x00
0x00 50AB		EXTI_CONF2	External interrupt port select register 2	0x00
0x00 50A9 to 0x00 50AF	Reserved area (7 bytes)			
0x00 50B0	RST	RST_CR	Reset control register	0x00
0x00 50B1		RST_SR	Reset status register	0x01
0x00 50B2	PWR	PWR_CSR1	Power control and status register 1	0x00
0x00 50B3		PWR_CSR2	Power control and status register 2	0x00
0x00 50B4 to 0x00 50BF	Reserved area (12 bytes)			

Table 8. General hardware register map (continued)

Address	Block	Register label	Register name	Reset status
0x00 50C0	CLK	CLK_CKDIVR	CLK clock master divider register	0x03
0x00 50C1		CLK_CRTCR	CLK clock RTC register	0x00 <sup>(1)</sup>
0x00 50C2		CLK_ICKCR	CLK internal clock control register	0x11
0x00 50C3		CLK_PCKENR1	CLK peripheral clock gating register 1	0x00
0x00 50C4		CLK_PCKENR2	CLK peripheral clock gating register 2	0x00
0x00 50C5		CLK_CCOR	CLK configurable clock control register	0x00
0x00 50C6		CLK_ECKCR	CLK external clock control register	0x00
0x00 50C7		CLK_SCSR	CLK system clock status register	0x01
0x00 50C8		CLK_SWR	CLK system clock switch register	0x01
0x00 50C9		CLK_SWCR	CLK clock switch control register	0xX0
0x00 50CA		CLK_CSSR	CLK clock security system register	0x00
0x00 50CB		CLK_CBEEPR	CLK clock BEEP register	0x00
0x00 50CC		CLK_HSICALR	CLK HSI calibration register	0xXX
0x00 50CD		CLK_HSITRIMR	CLK HSI clock calibration trimming register	0x00
0x00 50CE		CLK_HSIUNLCKR	CLK HSI unlock register	0x00
0x00 50CF		CLK_REGCSR	CLK main regulator control status register	0bxx11 100X
0x00 50D0		CLK_PCKENR3	CLK peripheral clock gating register 3	0x00
0x00 50D1 to 0x00 50D2		Reserved area (2 bytes)		
0x00 50D3	WWDG	WWDG_CR	WWDG control register	0x7F
0x00 50D4		WWDG_WR	WWDG window register	0x7F
0x00 50D5 to 00 50DF	Reserved area (11 bytes)			
0x00 50E0	IWDG	IWDG_KR	IWDG key register	0x01
0x00 50E1		IWDG_PR	IWDG prescaler register	0x00
0x00 50E2		IWDG_RLR	IWDG reload register	0xFF
0x00 50E3 to 0x00 50EF	Reserved area (13 bytes)			
0x00 50F0	BEEP	BEEP_CSR1	BEEP control/status register 1	0x00
0x00 50F1 0x00 50F2		Reserved area (2 bytes)		
0x00 50F3		BEEP_CSR2	BEEP control/status register 2	0x1F
0x00 50F4 to 0x00 513F	Reserved area (76 bytes)			

Table 8. General hardware register map (continued)

Address	Block	Register label	Register name	Reset status	
0x00 5140	RTC	RTC_TR1	RTC time register 1	0x00	
0x00 5141		RTC_TR2	RTC time register 2	0x00	
0x00 5142		RTC_TR3	RTC time register 3	0x00	
0x00 5143		Reserved area (1 byte)			
0x00 5144		RTC_DR1	RTC date register 1	0x01	
0x00 5145		RTC_DR2	RTC date register 2	0x21	
0x00 5146		RTC_DR3	RTC date register 3	0x00	
0x00 5147		Reserved area (1 byte)			
0x00 5148		RTC_CR1	RTC control register 1	0x00 <sup>(1)</sup>	
0x00 5149		RTC_CR2	RTC control register 2	0x00 <sup>(1)</sup>	
0x00 514A		RTC_CR3	RTC control register 3	0x00 <sup>(1)</sup>	
0x00 514B		Reserved area (1 byte)			
0x00 514C		RTC_ISR1	RTC initialization and status register 1	0x01	
0x00 514D		RTC_ISR2	RTC initialization and Status register 2	0x00	
0x00 514E 0x00 514F		Reserved area (2 bytes)			
0x00 5150		RTC_SPRERH	RTC synchronous prescaler register high	0x00 <sup>(1)</sup>	
0x00 5151		RTC_SPRERL	RTC synchronous prescaler register low	0xFF <sup>(1)</sup>	
0x00 5152		RTC_APRER	RTC asynchronous prescaler register	0x7F <sup>(1)</sup>	
0x00 5153		Reserved area (1 byte)			
0x00 5154		RTC_WUTRH	RTC wakeup timer register high	0xFF <sup>(1)</sup>	
0x00 5155		RTC_WUTRL	RTC wakeup timer register low	0xFF <sup>(1)</sup>	
0x00 5156		Reserved area (1 byte)			
0x00 5157		RTC_SSRL	RTC subsecond register low	0x00	
0x00 5158		RTC_SSRH	RTC subsecond register high	0x00	
0x00 5159		RTC_WPR	RTC write protection register	0x00	
0x00 5158		RTC_SSRH	RTC subsecond register high	0x00	
0x00 5159		RTC_WPR	RTC write protection register	0x00	
0x00 515A		RTC_SHIFTRH	RTC shift register high	0x00	
0x00 515B		RTC_SHIFTRL	RTC shift register low	0x00	
0x00 515C		RTC_ALRMAR1	RTC alarm A register 1	0x00 <sup>(1)</sup>	
0x00 515D		RTC_ALRMAR2	RTC alarm A register 2	0x00 <sup>(1)</sup>	
0x00 515E		RTC_ALRMAR3	RTC alarm A register 3	0x00 <sup>(1)</sup>	
0x00 515F	RTC_ALRMAR4	RTC alarm A register 4	0x00 <sup>(1)</sup>		

Table 8. General hardware register map (continued)

Address	Block	Register label	Register name	Reset status
0x00 5160 to 0x00 5163	RTC	Reserved area (4 bytes)		
0x00 5164		RTC_ALRMASRH	RTC alarm A subsecond register high	0x00 <sup>(1)</sup>
0x00 5165		RTC_ALRMASRL	RTC alarm A subsecond register low	0x00 <sup>(1)</sup>
0x00 5166		RTC_ALRMASMSKR	RTC alarm A masking register	0x00 <sup>(1)</sup>
0x00 5167 to 0x00 5169		Reserved area (3 bytes)		
0x00 516A		RTC_CALRH	RTC calibration register high	0x00 <sup>(1)</sup>
0x00 516B		RTC_CALRL	RTC calibration register low	0x00 <sup>(1)</sup>
0x00 516C to 0x00 518F		Reserved area (36 bytes)		
0x00 5190		CSSLSE_CSR	RTC CSS on LSE control and status register	0x00 <sup>(1)</sup>
0x00 5191 to 0x00 51FF		Reserved area (111 bytes)		
0x00 5200	SPI1	SPI1_CR1	SPI1 control register 1	0x00
0x00 5201		SPI1_CR2	SPI1 control register 2	0x00
0x00 5202		SPI1_ICR	SPI1 interrupt control register	0x00
0x00 5203		SPI1_SR	SPI1 status register	0x02
0x00 5204		SPI1_DR	SPI1 data register	0x00
0x00 5205		SPI1_CRCPR	SPI1 CRC polynomial register	0x07
0x00 5206		SPI1_RXCR	SPI1 Rx CRC register	0x00
0x00 5207		SPI1_TXCR	SPI1 Tx CRC register	0x00
0x00 5208 to 0x00 520F	Reserved area (8 bytes)			

Table 8. General hardware register map (continued)

Address	Block	Register label	Register name	Reset status
0x00 5210	I2C1	I2C1_CR1	I2C1 control register 1	0x00
0x00 5211		I2C1_CR2	I2C1 control register 2	0x00
0x00 5212		I2C1_FREQR	I2C1 frequency register	0x00
0x00 5213		I2C1_OARL	I2C1 own address register low	0x00
0x00 5214		I2C1_OARH	I2C1 own address register high	0x00
0x00 5215		I2C1_OAR2	I2C1 own address register for dual mode	0x00
0x00 5216		I2C1_DR	I2C1 data register	0x00
0x00 5217		I2C1_SR1	I2C1 status register 1	0x00
0x00 5218		I2C1_SR2	I2C1 status register 2	0x00
0x00 5219		I2C1_SR3	I2C1 status register 3	0x0X
0x00 521A		I2C1_ITR	I2C1 interrupt control register	0x00
0x00 521B		I2C1_CCRL	I2C1 clock control register low	0x00
0x00 521C		I2C1_CCRH	I2C1 clock control register high	0x00
0x00 521D		I2C1_TRISER	I2C1 TRISE register	0x02
0x00 521E		I2C1_PECR	I2C1 packet error checking register	0x00
0x00 521F to 0x00 522F		Reserved area (17 bytes)		
0x00 5230	USART1	USART1_SR	USART1 status register	0xC0
0x00 5231		USART1_DR	USART1 data register	0xFF
0x00 5232		USART1_BRR1	USART1 baud rate register 1	0x00
0x00 5233		USART1_BRR2	USART1 baud rate register 2	0x00
0x00 5234		USART1_CR1	USART1 control register 1	0x00
0x00 5235		USART1_CR2	USART1 control register 2	0x00
0x00 5236		USART1_CR3	USART1 control register 3	0x00
0x00 5237		USART1_CR4	USART1 control register 4	0x00
0x00 5238		USART1_CR5	USART1 control register 5	0x00
0x00 5239		USART1_GTR	USART1 guard time register	0x00
0x00 523A		USART1_PSCR	USART1 prescaler register	0x00
0x00 523B to 0x00 524F	Reserved area (21 bytes)			



Table 8. General hardware register map (continued)

Address	Block	Register label	Register name	Reset status
0x00 5250	TIM2	TIM2_CR1	TIM2 control register 1	0x00
0x00 5251		TIM2_CR2	TIM2 control register 2	0x00
0x00 5252		TIM2_SMCR	TIM2 Slave mode control register	0x00
0x00 5253		TIM2_ETR	TIM2 external trigger register	0x00
0x00 5254		TIM2_DER	TIM2 DMA1 request enable register	0x00
0x00 5255		TIM2_IER	TIM2 interrupt enable register	0x00
0x00 5256		TIM2_SR1	TIM2 status register 1	0x00
0x00 5257		TIM2_SR2	TIM2 status register 2	0x00
0x00 5258		TIM2_EGR	TIM2 event generation register	0x00
0x00 5259		TIM2_CCMR1	TIM2 capture/compare mode register 1	0x00
0x00 525A		TIM2_CCMR2	TIM2 capture/compare mode register 2	0x00
0x00 525B		TIM2_CCER1	TIM2 capture/compare enable register 1	0x00
0x00 525C		TIM2_CNTRH	TIM2 counter high	0x00
0x00 525D		TIM2_CNTRL	TIM2 counter low	0x00
0x00 525E		TIM2_PSCR	TIM2 prescaler register	0x00
0x00 525F		TIM2_ARRH	TIM2 auto-reload register high	0xFF
0x00 5260		TIM2_ARRL	TIM2 auto-reload register low	0xFF
0x00 5261		TIM2_CCR1H	TIM2 capture/compare register 1 high	0x00
0x00 5262		TIM2_CCR1L	TIM2 capture/compare register 1 low	0x00
0x00 5263		TIM2_CCR2H	TIM2 capture/compare register 2 high	0x00
0x00 5264		TIM2_CCR2L	TIM2 capture/compare register 2 low	0x00
0x00 5265		TIM2_BKR	TIM2 break register	0x00
0x00 5266		TIM2_OISR	TIM2 output idle state register	0x00
0x00 5267 to 0x00 527F	Reserved area (25 bytes)			

Table 8. General hardware register map (continued)

Address	Block	Register label	Register name	Reset status
0x00 5280	TIM3	TIM3_CR1	TIM3 control register 1	0x00
0x00 5281		TIM3_CR2	TIM3 control register 2	0x00
0x00 5282		TIM3_SMCR	TIM3 Slave mode control register	0x00
0x00 5283		TIM3_ETR	TIM3 external trigger register	0x00
0x00 5284		TIM3_DER	TIM3 DMA1 request enable register	0x00
0x00 5285		TIM3_IER	TIM3 interrupt enable register	0x00
0x00 5286		TIM3_SR1	TIM3 status register 1	0x00
0x00 5287		TIM3_SR2	TIM3 status register 2	0x00
0x00 5288		TIM3_EGR	TIM3 event generation register	0x00
0x00 5289		TIM3_CCMR1	TIM3 Capture/Compare mode register 1	0x00
0x00 528A		TIM3_CCMR2	TIM3 Capture/Compare mode register 2	0x00
0x00 528B		TIM3_CCER1	TIM3 Capture/Compare enable register 1	0x00
0x00 528C		TIM3_CNTRH	TIM3 counter high	0x00
0x00 528D		TIM3_CNTRL	TIM3 counter low	0x00
0x00 528E		TIM3_PSCR	TIM3 prescaler register	0x00
0x00 528F		TIM3_ARRH	TIM3 Auto-reload register high	0xFF
0x00 5290		TIM3_ARRL	TIM3 Auto-reload register low	0xFF
0x00 5291		TIM3_CCR1H	TIM3 Capture/Compare register 1 high	0x00
0x00 5292		TIM3_CCR1L	TIM3 Capture/Compare register 1 low	0x00
0x00 5293		TIM3_CCR2H	TIM3 Capture/Compare register 2 high	0x00
0x00 5294		TIM3_CCR2L	TIM3 Capture/Compare register 2 low	0x00
0x00 5295		TIM3_BKR	TIM3 break register	0x00
0x00 5296		TIM3_OISR	TIM3 output idle state register	0x00
0x00 5297 to 0x00 52DF	Reserved area (72 bytes)			

Table 8. General hardware register map (continued)

Address	Block	Register label	Register name	Reset status
0x00 52E0	TIM4	TIM4_CR1	TIM4 control register 1	0x00
0x00 52E1		TIM4_CR2	TIM4 control register 2	0x00
0x00 52E2		TIM4_SMCR	TIM4 Slave mode control register	0x00
0x00 52E3		TIM4_DER	TIM4 DMA1 request enable register	0x00
0x00 52E4		TIM4_IER	TIM4 Interrupt enable register	0x00
0x00 52E5		TIM4_SR1	TIM4 status register 1	0x00
0x00 52E6		TIM4_EGR	TIM4 Event generation register	0x00
0x00 52E7		TIM4_CNTR	TIM4 counter	0x00
0x00 52E8		TIM4_PSCR	TIM4 prescaler register	0x00
0x00 52E9		TIM4_ARR	TIM4 Auto-reload register	0x00
0x00 52EA to 0x00 52FE		Reserved area (21 bytes)		
0x00 52FF	IRTIM	IR_CR	Infrared control register	0x00
0x00 5317 to 0x00 533F	Reserved area (41 bytes)			
0x00 5340	ADC1	ADC1_CR1	ADC1 configuration register 1	0x00
0x00 5341		ADC1_CR2	ADC1 configuration register 2	0x00
0x00 5342		ADC1_CR3	ADC1 configuration register 3	0x1F
0x00 5343		ADC1_SR	ADC1 status register	0x00
0x00 5344		ADC1_DRH	ADC1 data register high	0x00
0x00 5345		ADC1_DRL	ADC1 data register low	0x00
0x00 5346		ADC1_HTRH	ADC1 high threshold register high	0x0F
0x00 5347		ADC1_HTRL	ADC1 high threshold register low	0xFF
0x00 5348		ADC1_LTRH	ADC1 low threshold register high	0x00
0x00 5349		ADC1_LTRL	ADC1 low threshold register low	0x00
0x00 534A		ADC1_SQR1	ADC1 channel sequence 1 register	0x00
0x00 534B		ADC1_SQR2	ADC1 channel sequence 2 register	0x00
0x00 534C		ADC1_SQR3	ADC1 channel sequence 3 register	0x00
0x00 534D		ADC1_SQR4	ADC1 channel sequence 4 register	0x00
0x00 534E		ADC1_TRIGR1	ADC1 trigger disable 1	0x00
0x00 534F		ADC1_TRIGR2	ADC1 trigger disable 2	0x00
0x00 5350		ADC1_TRIGR3	ADC1 trigger disable 3	0x00
0x00 5351	ADC1_TRIGR4	ADC1 trigger disable 4	0x00	

Table 8. General hardware register map (continued)

Address	Block	Register label	Register name	Reset status
0x00 53C8 to 0x00 542F	Reserved area (104 bytes)			
0x00 5430	RI	Reserved area (1 byte)		0x00
0x00 5431		RI_ICR1	RI timer input capture routing register 1	0x00
0x00 5432		RI_ICR2	RI timer input capture routing register 2	0x00
0x00 5433		RI_IOIR1	RI I/O input register 1	0xXX
0x00 5434		RI_IOIR2	RI I/O input register 2	0xXX
0x00 5435		RI_IOIR3	RI I/O input register 3	0xXX
0x00 5436		RI_IOCMR1	RI I/O control mode register 1	0x00
0x00 5437		RI_IOCMR2	RI I/O control mode register 2	0x00
0x00 5438		RI_IOCMR3	RI I/O control mode register 3	0x00
0x00 5439		RI_IOSR1	RI I/O switch register 1	0x00
0x00 543A		RI_IOSR2	RI I/O switch register 2	0x00
0x00 543B		RI_IOSR3	RI I/O switch register 3	0x00
0x00 543C		RI_IOGCR	RI I/O group control register	0xFF
0x00 543D		RI_ASCR1	RI analog switch register 1	0x00
0x00 543E		RI_ASCR2	RI analog switch register 2	0x00
0x00 543F		RI_RCR	RI resistor control register	0x00
0x00 5440		COMP1/ COMP2	COMP_CSR1	Comparator control and status register 1
0x00 5441	COMP_CSR2		Comparator control and status register 2	0x00
0x00 5442	COMP_CSR3		Comparator control and status register 3	0x00
0x00 5443	COMP_CSR4		Comparator control and status register 4	0x00
0x00 5444	COMP_CSR5		Comparator control and status register 5	0x00
0x00 5445 to 0x00 544F	Reserved area (11 bytes)			
0x00 5450	RI	RI_CR	RI I/O control register	0x00
0x00 5451		RI_MASKR1	RI I/O mask register 1	0x00
0x00 5452		RI_MASKR2	RI I/O mask register 2	0x00
0x00 5453		RI_MASKR3	RI I/O mask register 3	0x00
0x00 5454		RI_MASKR4	RI I/O mask register 4	0x00
0x00 5455		RI_IOIR4	RI I/O input register 4	0xXX
0x00 5456		RI_IOCMR4	RI I/O control mode register 4	0x00
0x00 5457		RI_IOSR4	RI I/O switch register 4	0x00

1. These registers are not impacted by a system reset. They are reset at power-on.

Table 9. CPU/SWIM/debug module/interrupt controller registers

Address	Block	Register Label	Register Name	Reset Status
0x00 7F00	CPU <sup>(1)</sup>	A	Accumulator	0x00
0x00 7F01		PCE	Program counter extended	0x00
0x00 7F02		PCH	Program counter high	0x00
0x00 7F03		PCL	Program counter low	0x00
0x00 7F04		XH	X index register high	0x00
0x00 7F05		XL	X index register low	0x00
0x00 7F06		YH	Y index register high	0x00
0x00 7F07		YL	Y index register low	0x00
0x00 7F08		SPH	Stack pointer high	0x03
0x00 7F09		SPL	Stack pointer low	0xFF
0x00 7F0A		CCR	Condition code register	0x28
0x00 7F0B to 0x00 7F5F		CPU	Reserved area (85 bytes)	
0x00 7F60	CFG_GCR		Global configuration register	0x00
0x00 7F70	ITC-SPR	ITC_SPR1	Interrupt Software priority register 1	0xFF
0x00 7F71		ITC_SPR2	Interrupt Software priority register 2	0xFF
0x00 7F72		ITC_SPR3	Interrupt Software priority register 3	0xFF
0x00 7F73		ITC_SPR4	Interrupt Software priority register 4	0xFF
0x00 7F74		ITC_SPR5	Interrupt Software priority register 5	0xFF
0x00 7F75		ITC_SPR6	Interrupt Software priority register 6	0xFF
0x00 7F76		ITC_SPR7	Interrupt Software priority register 7	0xFF
0x00 7F77		ITC_SPR8	Interrupt Software priority register 8	0xFF
0x00 7F78 to 0x00 7F79	Reserved area (2 bytes)			
0x00 7F80	SWIM	SWIM_CSR	SWIM control status register	0x00
0x00 7F81 to 0x00 7F8F	Reserved area (15 bytes)			

**Table 9. CPU/SWIM/debug module/interrupt controller registers (continued)**

Address	Block	Register Label	Register Name	Reset Status	
0x00 7F90	DM	DM_BK1RE	DM breakpoint 1 register extended byte	0xFF	
0x00 7F91		DM_BK1RH	DM breakpoint 1 register high byte	0xFF	
0x00 7F92		DM_BK1RL	DM breakpoint 1 register low byte	0xFF	
0x00 7F93		DM_BK2RE	DM breakpoint 2 register extended byte	0xFF	
0x00 7F94		DM_BK2RH	DM breakpoint 2 register high byte	0xFF	
0x00 7F95		DM_BK2RL	DM breakpoint 2 register low byte	0xFF	
0x00 7F96		DM_CR1	DM Debug module control register 1	0x00	
0x00 7F97		DM_CR2	DM Debug module control register 2	0x00	
0x00 7F98		DM_CSR1	DM Debug module control/status register 1	0x10	
0x00 7F99		DM_CSR2	DM Debug module control/status register 2	0x00	
0x00 7F9A		DM_ENFCTR	DM enable function register	0xFF	
0x00 7F9B to 0x00 7F9F		Reserved area (5 bytes)			

1. Accessible by debug module only

## 6 Interrupt vector mapping

Table 10. Interrupt mapping

IRQ No.	Source block	Description	Wakeup from Halt mode	Wakeup from Active-halt mode	Wakeup from Wait (WFI mode)	Wakeup from Wait (WFE mode) <sup>(1)</sup>	Vector address
	RESET	Reset	Yes	Yes	Yes	Yes	0x00 8000
	TRAP	Software interrupt	-	-	-	-	0x00 8004
0	TLI <sup>(2)</sup>	External top level interrupt	-	-	-	-	0x00 8008
1	FLASH	FLASH end of programing/ write attempted to protected page interrupt	-	-	Yes	Yes	0x00 800C
2	DMA1 0/1	DMA1 channels 0/1 half transaction/transaction complete interrupt	-	-	Yes	Yes	0x00 8010
3	DMA1 2/3	DMA1 channels 2/3 half transaction/transaction complete interrupt	-	-	Yes	Yes	0x00 8014
4	RTC	RTC alarm A/ wakeup/tamper 1/ tamper 2/tamper 3	Yes	Yes	Yes	Yes	0x00 8018
5	EXTIE/ PVD	External interrupt port E PVD interrupt	Yes	Yes	Yes	Yes	0x00 801C
6	EXTIB	External interrupt port B	Yes	Yes	Yes	Yes	0x00 8020
7	EXTID	External interrupt port D	Yes	Yes	Yes	Yes	0x00 8024
8	EXTI0	External interrupt 0	Yes	Yes	Yes	Yes	0x00 8028
9	EXTI1	External interrupt 1	Yes	Yes	Yes	Yes	0x00 802C
10	EXTI2	External interrupt 2	Yes	Yes	Yes	Yes	0x00 8030
11	EXTI3	External interrupt 3	Yes	Yes	Yes	Yes	0x00 8034
12	EXTI4	External interrupt 4	Yes	Yes	Yes	Yes	0x00 8038
13	EXTI5	External interrupt 5	Yes	Yes	Yes	Yes	0x00 803C
14	EXTI6	External interrupt 6	Yes	Yes	Yes	Yes	0x00 8040
15	EXTI7	External interrupt 7	Yes	Yes	Yes	Yes	0x00 8044
16	Reserved						0x00 8048
17	CLK	CLK system clock switch/ CSS interrupt	-	-	Yes	Yes	0x00 804C
18	COMP1/ COMP2/ ADC1	COMP1 interrupt COMP2 interrupt ACD1 end of conversion/ analog watchdog/ overrun interrupt	Yes	Yes	Yes	Yes	0x00 8050

Table 10. Interrupt mapping (continued)

IRQ No.	Source block	Description	Wakeup from Halt mode	Wakeup from Active-halt mode	Wakeup from Wait (WFI mode)	Wakeup from Wait (WFE mode) <sup>(1)</sup>	Vector address
19	TIM2	TIM2 update/overflow/trigger/break interrupt	-	-	Yes	Yes	0x00 8054
20	TIM2	TIM2 capture/compare interrupt	-	-	Yes	Yes	0x00 8058
21	TIM3	TIM3 update/overflow/trigger/break interrupt	-	-	Yes	Yes	0x00 805C
22	TIM3	TIM3 capture/compare interrupt	-	-	Yes	Yes	0x00 8060
23	RI	RI trigger interrupt	-	-	Yes	-	0x00 8064
24	Reserved						0x00 8068
25	TIM4	TIM4 update/overflow/trigger interrupt	-	-	Yes	Yes	0x00 806C
26	SPI1	SPI1 TX buffer empty/RX buffer not empty/error/wakeup interrupt	Yes	Yes	Yes	Yes	0x00 8070
27	USART1	USART1 transmit data register empty/transmission complete interrupt	-	-	Yes	Yes	0x00 8074
28	USART1	USART1 received data ready/overrun error/idle line detected/parity error/global error interrupt	-	-	Yes	Yes	0x00 8078
29	I <sup>2</sup> C1	I <sup>2</sup> C1 interrupt <sup>(3)</sup>	Yes	Yes	Yes	Yes	0x00 807C

1. The Low power wait mode is entered when executing a WFE instruction in Low power run mode. In WFE mode, the interrupt is served if it has been previously enabled. After processing the interrupt, the processor goes back to WFE mode. When the interrupt is configured as a wakeup event, the CPU wakes up and resumes processing.
2. The TLI interrupt is the logic OR between TIM2 overflow interrupt, and TIM4 overflow interrupts.
3. The device is woken up from Halt or Active-halt mode only when the address received matches the interface address.



## 7 Electrical parameters

### 7.1 Parameter conditions

Unless otherwise specified, all voltages are referred to  $V_{SS}$ .

#### 7.1.1 Minimum and maximum values

Unless otherwise specified the minimum and maximum values are guaranteed in the worst conditions of ambient temperature, supply voltage and frequencies by tests in production on 100% of the devices with an ambient temperature at  $T_A = 25\text{ }^\circ\text{C}$  and  $T_A = T_A \text{ max}$  (given by the selected temperature range).

Data based on characterization results, design simulation and/or technology characteristics are indicated in the table footnotes and are not tested in production. Based on characterization, the minimum and maximum values refer to sample tests and represent the mean value plus or minus three times the standard deviation ( $\text{mean} \pm 3\sigma$ ).

#### 7.1.2 Typical values

Unless otherwise specified, typical data are based on  $T_A = 25\text{ }^\circ\text{C}$ ,  $V_{DD} = 3\text{ V}$ . They are given only as design guidelines and are not tested.

Typical ADC1 accuracy values are determined by characterization of a batch of samples from a standard diffusion lot over the full temperature range, where 95% of the devices have an error less than or equal to the value indicated ( $\text{mean} \pm 2\sigma$ ).

#### 7.1.3 Typical curves

Unless otherwise specified, all typical curves are given only as design guidelines and are not tested.

#### 7.1.4 Loading capacitor

The loading conditions used for pin parameter measurement are shown in [Figure 9](#).

**Figure 9. Pin loading conditions**

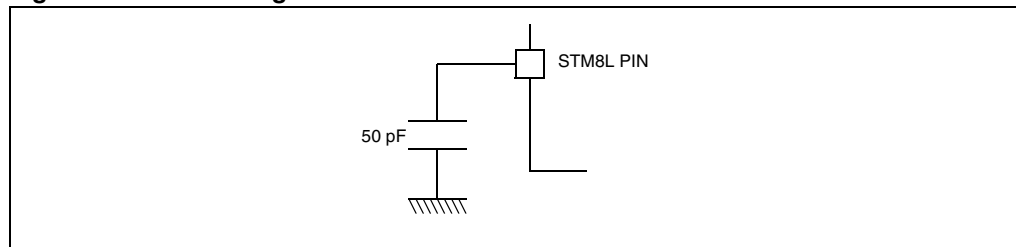

### 7.1.5 Pin input voltage

The input voltage measurement on a pin of the device is described in [Figure 10](#).

**Figure 10. Pin input voltage**

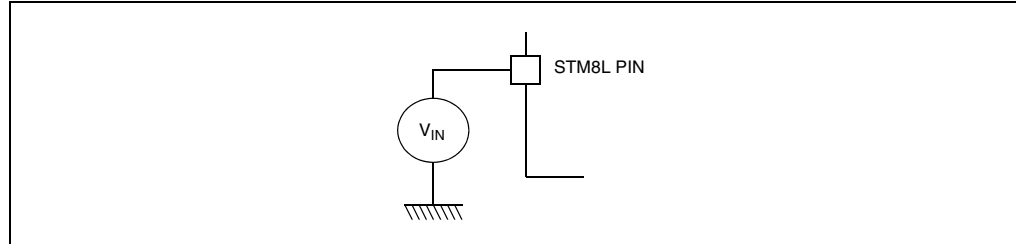

## 7.2 Absolute maximum ratings

Stresses above those listed as “absolute maximum ratings” may cause permanent damage to the device. This is a stress rating only and functional operation of the device under these conditions is not implied. Exposure to maximum rating conditions for extended periods may affect device reliability.

**Table 11. Voltage characteristics**

Symbol	Ratings	Min	Max	Unit
$V_{DD} - V_{SS}$	External supply voltage (including $V_{DD}$ , $V_{DDA}$ , and $V_{DDIO}$ ) <sup>(1)</sup>	- 0.3	4.0	V
$V_{IN}^{(2)}$	Input voltage on true open-drain pins (PC0 and PC1)	$V_{SS} - 0.3$	$V_{DD} + 4.0$	V
	Input voltage on 3.6 V tolerant pins	$V_{SS} - 0.3$	4.0	
	Input voltage on any other pin	$V_{SS} - 0.3$	4.0	
$V_{ESD}$	Electrostatic discharge voltage	see <a href="#">Absolute maximum ratings (electrical sensitivity)</a> on page 94		

- All power ( $V_{DD}$ ,  $V_{DDA}$ ,  $V_{DDIO}$ ) and ground ( $V_{SS}$ ,  $V_{SSA}$ ,  $V_{SSIO}$ ) pins must always be connected to the external power supply.
- $V_{IN}$  maximum must always be respected. Refer to [Table 12](#) for maximum allowed injected current values.

**Table 12. Current characteristics**

Symbol	Ratings	Max.	Unit
$I_{VDD}$	Total current into $V_{DD}$ power line (source)	80	mA
$I_{VSS}$	Total current out of $V_{SS}$ ground line (sink)	80	
$I_{IO}$	Output current sunk by IR_TIM pin (with high sink LED driver capability)	80	
	Output current sunk by any other I/O and control pin	25	
	Output current sourced by any I/Os and control pin	- 25	
$I_{INJ(PIN)}$	Injected current on true open-drain pins (PC0 and PC1) <sup>(1)</sup>	- 5 / +0	
	Injected current on 3.6 V tolerant pins <sup>(1)</sup>	- 5 / +0	
	Injected current on any other pin <sup>(1)</sup>	- 5 / +5	
$\Sigma I_{INJ(PIN)}$	Total injected current (sum of all I/O and control pins) <sup>(2)</sup>	$\pm 25$	

1. A positive injection is induced by  $V_{IN} > V_{DD}$  while a negative injection is induced by  $V_{IN} < V_{SS}$ .  $I_{INJ(PIN)}$  must never be exceeded. Refer to [Table 11](#) for maximum allowed input voltage values.

2. When several inputs are submitted to a current injection, the maximum  $\Sigma I_{INJ(PIN)}$  is the absolute sum of the positive and negative injected currents (instantaneous values).

**Table 13. Thermal characteristics**

Symbol	Ratings	Value	Unit
$T_{STG}$	Storage temperature range	-65 to +150	°C
$T_J$	Maximum junction temperature	150	

## 7.3 Operating conditions

Subject to general operating conditions for  $V_{DD}$  and  $T_A$ .

### 7.3.1 General operating conditions

**Table 14. General operating conditions**

Symbol	Parameter	Conditions		Min.	Max.	Unit
$f_{SYSCLK}^{(1)}$	System clock frequency	1.65 V $\leq V_{DD} < 3.6$ V		0	16	MHz
$V_{DD}$	Standard operating voltage			1.65 <sup>(2)</sup>	3.6	V
$V_{DDA}$	Analog operating voltage	ADC1 not used	Must be at the same potential as $V_{DD}$	1.65 <sup>(2)</sup>	3.6	V
		ADC1 used		1.8	3.6	V
$P_D^{(3)}$	Power dissipation at $T_A = 85$ °C for suffix 3 and suffix 6 devices	LQFP48			288	mW
		UFQFPN32			288	
		UFQFPN28			250	
		UFQFPN20			196	
		TSSOP20			181	
	Power dissipation at $T_A = 125$ °C for suffix 3 devices	LQFP48			77	
		UFQFPN32			185	
		UFQFPN28			62	
		UFQFPN20			49	
		TSSOP20			45	
$T_A$	Temperature range	1.65 V $\leq V_{DD} < 3.6$ V (6 suffix version)		-40	85	°C
		1.65 V $\leq V_{DD} < 3.6$ V (3 suffix version)		-40	125	
$T_J$	Junction temperature range	-40 °C $\leq T_A < 85$ °C (6 suffix version)		-40	105 <sup>(4)</sup>	
		-40 °C $\leq T_A < 125$ °C (3 suffix version)		-40	130 <sup>(4)</sup>	

1.  $f_{SYSCLK} = f_{CPU}$

2. 1.8 V at power-up, 1.65 V at power-down if BOR is disabled

3. To calculate  $P_{Dmax}(T_A)$ , use the formula  $P_{Dmax} = (T_{Jmax} - T_A) / \Theta_{JA}$  with  $T_{Jmax}$  in this table and  $\Theta_{JA}$  in "Thermal characteristics" table.

4.  $T_J$  max is given by the test limit. Above this value, the product behavior is not guaranteed.

### 7.3.2 Embedded reset and power control block characteristics

**Table 15. Embedded reset and power control block characteristics**

Symbol	Parameter	Conditions	Min	Typ	Max	Unit	
$t_{VDD}$	$V_{DD}$ rise time rate	BOR detector enabled	0 <sup>(1)</sup>		$\infty$ <sup>(1)</sup>	$\mu\text{s/V}$	
	$V_{DD}$ fall time rate	BOR detector enabled	20 <sup>(1)</sup>		$\infty$ <sup>(1)</sup>		
$t_{TEMP}$	Reset release delay	$V_{DD}$ rising		3 <sup>(1)</sup>		ms	
$V_{PDR}$	Power-down reset threshold	Falling edge	1.30 <sup>(2)</sup>	1.50	1.65	V	
$V_{BOR0}$	Brown-out reset threshold 0 (BOR_TH[2:0]=000)	Falling edge	1.66	1.70	1.74	V	
		Rising edge	1.39	1.75	1.81		
$V_{BOR1}$	Brown-out reset threshold 1 (BOR_TH[2:0]=001)	Falling edge	1.89	1.93	1.97		
		Rising edge	1.98	2.03	2.07		
$V_{BOR2}$	Brown-out reset threshold 2 (BOR_TH[2:0]=010)	Falling edge	2.25	2.30	2.35		
		Rising edge	2.35	2.40	2.44		
$V_{BOR3}$	Brown-out reset threshold 3 (BOR_TH[2:0]=011)	Falling edge	2.50	2.55	2.60		
		Rising edge	2.59	2.65	2.70		
$V_{BOR4}$	Brown-out reset threshold 4 (BOR_TH[2:0]=100)	Falling edge	2.74	2.79	2.85		
		Rising edge	2.83	2.89	2.95		
$V_{PVD0}$	PVD threshold 0	Falling edge	2.82	1.85	1.88		V
		Rising edge	1.89	1.94	1.97		
$V_{PVD1}$	PVD threshold 1	Falling edge	2.04	2.05	2.08		
		Rising edge	2.12	2.14	2.17		
$V_{PVD2}$	PVD threshold 2	Falling edge	2.21	2.24	2.28		
		Rising edge	2.31	2.33	2.37		
$V_{PVD3}$	PVD threshold 3	Falling edge	2.41	2.44	2.48		
		Rising edge	2.51	2.53	2.57		
$V_{PVD4}$	PVD threshold 4	Falling edge	2.61	2.64	2.69		
		Rising edge	2.71	2.74	2.79		
$V_{PVD5}$	PVD threshold 5	Falling edge	2.79	2.83	2.88		
		Rising edge	2.90	2.94	2.99		
$V_{PVD6}$	PVD threshold 6	Falling edge	3.01	3.04	3.09		
		Rising edge	3.12	3.15	3.20		

1. Data guaranteed by design, not tested in production.

2. Data based on characterization results, not tested in production.

Figure 11. POR/BOR thresholds

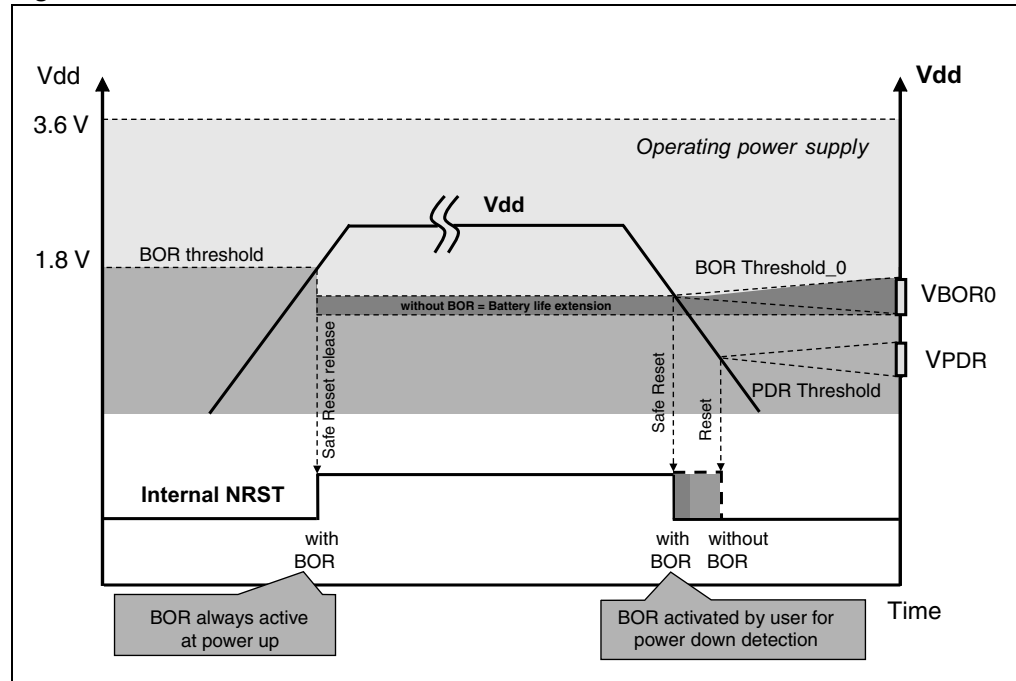

### 7.3.3 Supply current characteristics

#### Total current consumption

The MCU is placed under the following conditions:

- All I/O pins in input mode with a static value at  $V_{DD}$  or  $V_{SS}$  (no load)
- All peripherals are disabled except if explicitly mentioned.

In the following table, data are based on characterization results, unless otherwise specified.

Subject to general operating conditions for  $V_{DD}$  and  $T_A$ .

Table 16. Total current consumption in Run mode

Symbol	Parameter	Conditions <sup>(1)</sup>		Typ	Max				Unit	
					55 °C	85 °C	105 °C <sup>(2)</sup>	125 °C <sup>(2)</sup>		
I <sub>DD(RUN)</sub>	Supply current in run mode <sup>(3)</sup>	All peripherals OFF, code executed from RAM, V <sub>DD</sub> from 1.65 V to 3.6 V	HSI RC osc. (16 MHz) <sup>(4)</sup>	f <sub>CPU</sub> = 125 kHz	0.39	0.47	0.49	0.52	0.55	mA
				f <sub>CPU</sub> = 1 MHz	0.48	0.56	0.58	0.61	0.65	
				f <sub>CPU</sub> = 4 MHz	0.75	0.84	0.86	0.91	0.99	
				f <sub>CPU</sub> = 8 MHz	1.10	1.20	1.25	1.31	1.40	
				f <sub>CPU</sub> = 16 MHz	1.85	1.93	2.12 <sup>(6)</sup>	2.29 <sup>(6)</sup>	2.36 <sup>(6)</sup>	
			HSE external clock (f <sub>CPU</sub> =f <sub>HSE</sub> ) <sup>(5)</sup>	f <sub>CPU</sub> = 125 kHz	0.05	0.06	0.09	0.11	0.12	
				f <sub>CPU</sub> = 1 MHz	0.18	0.19	0.20	0.22	0.23	
				f <sub>CPU</sub> = 4 MHz	0.55	0.62	0.64	0.71	0.77	
				f <sub>CPU</sub> = 8 MHz	0.99	1.20	1.21	1.22	1.24	
			LSI RC osc. (typ. 38 kHz)	f <sub>CPU</sub> = f <sub>LSI</sub>	0.040	0.045	0.046	0.048	0.050	
				LSE external clock (32.768 kHz)	f <sub>CPU</sub> = f <sub>LSE</sub>	0.035	0.040	0.048 <sup>(6)</sup>	0.050	
			I <sub>DD(RUN)</sub>	Supply current in Run mode	All peripherals OFF, code executed from Flash, V <sub>DD</sub> from 1.65 V to 3.6 V	HSI RC osc. <sup>(7)</sup>	f <sub>CPU</sub> = 125 kHz	0.43	0.55	
f <sub>CPU</sub> = 1 MHz	0.60	0.77					0.80	0.82	0.87	
f <sub>CPU</sub> = 4 MHz	1.11	1.34					1.37	1.39	1.43	
f <sub>CPU</sub> = 8 MHz	1.90	2.20					2.23	2.31	2.40	
f <sub>CPU</sub> = 16 MHz	3.8	4.60					4.75	4.87	4.88	
HSE external clock (f <sub>CPU</sub> =f <sub>HSE</sub> ) <sup>(5)</sup>	f <sub>CPU</sub> = 125 kHz	0.30				0.36	0.39	0.44	0.47	
	f <sub>CPU</sub> = 1 MHz	0.40				0.50	0.52	0.55	0.56	
	f <sub>CPU</sub> = 4 MHz	1.15				1.31	1.40	1.45	1.48	
	f <sub>CPU</sub> = 8 MHz	2.17				2.33	2.44	2.56	2.77	
LSI RC osc.	f <sub>CPU</sub> = f <sub>LSI</sub>	0.110				0.123	0.130	0.140	0.150	
	LSE ext. clock (32.768 kHz) <sup>(8)</sup>	f <sub>CPU</sub> = f <sub>LSE</sub>				0.100	0.101	0.104	0.119	0.122

1. All peripherals OFF, V<sub>DD</sub> from 1.65 V to 3.6 V, HSI internal RC osc. , f<sub>CPU</sub>=f<sub>SYSClk</sub>
2. For devices with suffix 3
3. CPU executing typical data processing

4. The run from RAM consumption can be approximated with the linear formula:  
 $I_{DD}(\text{run\_from\_RAM}) = \text{Freq} * 90 \mu\text{A}/\text{MHz} + 380 \mu\text{A}$
5. Oscillator bypassed (HSEBYP = 1 in CLK\_ECKCR). When configured for external crystal, the HSE consumption ( $I_{DD \text{ HSE}}$ ) must be added. Refer to [Table 27](#).
6. Tested in production.
7. The run from Flash consumption can be approximated with the linear formula:  
 $I_{DD}(\text{run\_from\_Flash}) = \text{Freq} * 195 \mu\text{A}/\text{MHz} + 440 \mu\text{A}$
8. Oscillator bypassed (LSEBYP = 1 in CLK\_ECKCR). When configured for external crystal, the LSE consumption ( $I_{DD \text{ LSE}}$ ) must be added. Refer to [Table 28](#).

**Figure 12. Typ.  $I_{DD}(\text{RUN})$  vs.  $V_{DD}$ ,  $f_{\text{CPU}} = 16 \text{ MHz}$**

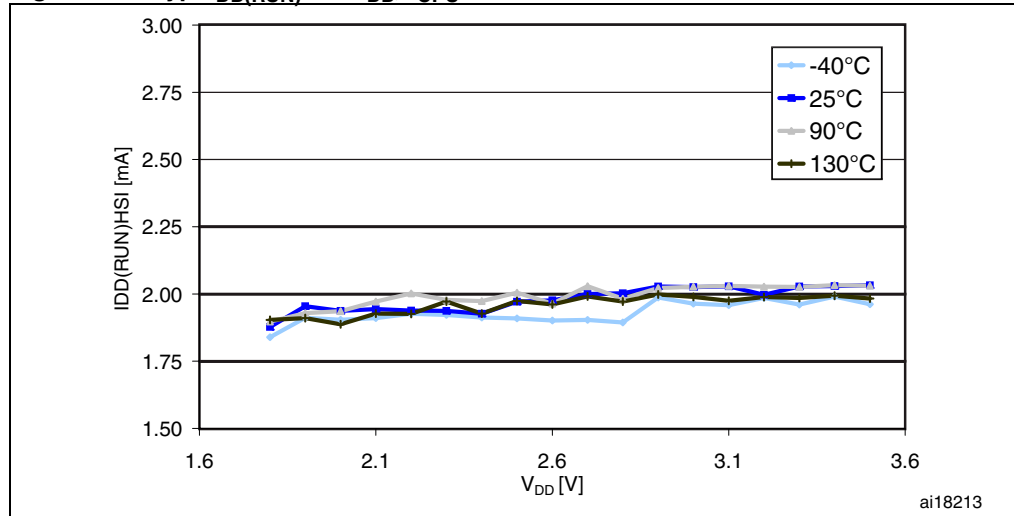

1. Typical current consumption measured with code executed from RAM



In the following table, data are based on characterization results, unless otherwise specified.

**Table 17. Total current consumption in Wait mode**

Symbol	Parameter	Conditions <sup>(1)</sup>	Typ	Max				Unit		
				55 °C	85 °C	105 °C (2)	125 °C (2)			
I <sub>DD(Wait)</sub>	Supply current in Wait mode	CPU not clocked, all peripherals OFF, code executed from RAM with Flash in I <sub>DDQ</sub> mode <sup>(3)</sup> , V <sub>DD</sub> from 1.65 V to 3.6 V	HSI	f <sub>CPU</sub> = 125 kHz	0.33	0.39	0.41	0.43	0.45	mA
				f <sub>CPU</sub> = 1 MHz	0.35	0.41	0.44	0.45	0.48	
				f <sub>CPU</sub> = 4 MHz	0.42	0.51	0.52	0.54	0.58	
				f <sub>CPU</sub> = 8 MHz	0.52	0.57	0.58	0.59	0.62	
				f <sub>CPU</sub> = 16 MHz	0.68	0.76	0.79	0.82 <sup>(5)</sup>	0.85 <sup>(5)</sup>	
			HSE external clock (f <sub>CPU</sub> =f <sub>HSE</sub> ) <sup>(4)</sup>	f <sub>CPU</sub> = 125 kHz	0.032	0.056	0.068	0.072	0.093	
				f <sub>CPU</sub> = 1 MHz	0.078	0.121	0.144	0.163	0.197	
				f <sub>CPU</sub> = 4 MHz	0.218	0.26	0.30	0.36	0.40	
				f <sub>CPU</sub> = 8 MHz	0.40	0.52	0.57	0.62	0.66	
			LSI	f <sub>CPU</sub> = f <sub>LSI</sub>	0.035	0.044	0.046	0.049	0.054	
				LSE <sup>(6)</sup> external clock (32.768 kHz)	f <sub>CPU</sub> = f <sub>LSE</sub>	0.032	0.036	0.038	0.044	
			I <sub>DD(Wait)</sub>	Supply current in Wait mode	CPU not clocked, all peripherals OFF, code executed from Flash, V <sub>DD</sub> from 1.65 V to 3.6 V	HSI	f <sub>CPU</sub> = 125 kHz	0.38	0.48	
f <sub>CPU</sub> = 1 MHz	0.41	0.49					0.51	0.53	0.59	
f <sub>CPU</sub> = 4 MHz	0.50	0.57					0.58	0.62	0.66	
f <sub>CPU</sub> = 8 MHz	0.60	0.66					0.68	0.72	0.74	
f <sub>CPU</sub> = 16 MHz	0.79	0.84					0.86	0.87	0.90	
HSE <sup>(4)</sup> external clock (f <sub>CPU</sub> =HSE)	f <sub>CPU</sub> = 125 kHz	0.06				0.08	0.09	0.10	0.12	
	f <sub>CPU</sub> = 1 MHz	0.10				0.17	0.18	0.19	0.22	
	f <sub>CPU</sub> = 4 MHz	0.24				0.36	0.39	0.41	0.44	
	f <sub>CPU</sub> = 8 MHz	0.50				0.58	0.61	0.62	0.64	
LSI	f <sub>CPU</sub> = f <sub>LSI</sub>	0.055				0.058	0.065	0.073	0.080	
	LSE <sup>(6)</sup> external clock (32.768 kHz)	f <sub>CPU</sub> = f <sub>LSE</sub>				0.051	0.056	0.060	0.065	0.073

1. All peripherals OFF, V<sub>DD</sub> from 1.65 V to 3.6 V, HSI internal RC osc. , f<sub>CPU</sub> = f<sub>SYSCLK</sub>

2. For temperature range 3.
3. Flash is configured in  $I_{DDQ}$  mode in Wait mode by setting the EPM or WAITM bit in the Flash\_CR1 register.
4. Oscillator bypassed (HSEBYP = 1 in CLK\_ECKCR). When configured for external crystal, the HSE consumption ( $I_{DD\ HSE}$ ) must be added. Refer to [Table 27](#).
5. Tested in production.
6. Oscillator bypassed (LSEBYP = 1 in CLK\_ECKCR). When configured for external crystal, the LSE consumption ( $I_{DD\ HSE}$ ) must be added. Refer to [Table 28](#).

**Figure 13. Typ.  $I_{DD(Wait)}$  vs.  $V_{DD}$ ,  $f_{CPU} = 16\ MHz$  <sup>1)</sup>**

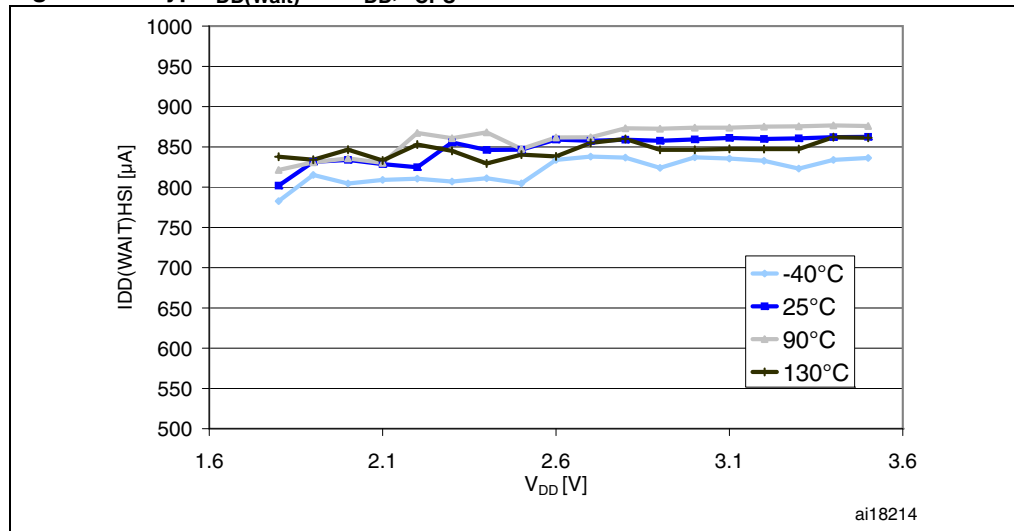

1. Typical current consumption measured with code executed from Flash memory.

In the following table, data are based on characterization results, unless otherwise specified.

**Table 18. Total current consumption and timing in Low power run mode at  $V_{DD} = 1.65$  V to 3.6 V**

Symbol	Parameter	Conditions <sup>(1)(2)</sup>		Typ	Max	Unit	
$I_{DD(LPR)}$	Supply current in Low power run mode	LSI RC osc. (at 38 kHz)	all peripherals OFF	$T_A = -40$ °C to 25 °C	5.1	5.4	$\mu$ A
				$T_A = 55$ °C	5.7	6	
				$T_A = 85$ °C	6.8	7.5	
				$T_A = 105$ °C	9.2	10.4	
				$T_A = 125$ °C	13.4	16.6	
			with TIM2 active <sup>(3)</sup>	$T_A = -40$ °C to 25 °C	5.4	5.7	
				$T_A = 55$ °C	6.0	6.3	
				$T_A = 85$ °C	7.2	7.8	
				$T_A = 105$ °C	9.4	10.7	
				$T_A = 125$ °C	13.8	17	
		LSE <sup>(4)</sup> external clock (32.768 kHz)	all peripherals OFF	$T_A = -40$ °C to 25 °C	5.25	5.6	
				$T_A = 55$ °C	5.67	6.1	
				$T_A = 85$ °C	5.85	6.3	
				$T_A = 105$ °C	7.11	7.6	
				$T_A = 125$ °C	9.84	12	
			with TIM2 active <sup>(3)</sup>	$T_A = -40$ °C to 25 °C	5.59	6	
$T_A = 55$ °C	6.10			6.4			
$T_A = 85$ °C	6.30			7			
$T_A = 105$ °C	7.55			8.4			
$T_A = 125$ °C	10.1			15			

1. No floating I/Os

2.  $T_A > 85$  °C is valid only for devices with suffix 3 temperature range.

3. Timer 2 clock enabled and counter running

4. Oscillator bypassed (LSEBYP = 1 in CLK\_ECKCR). When configured for external crystal, the LSE consumption ( $I_{DD LSE}$ ) must be added. Refer to [Table 28](#)

Figure 14. Typ.  $I_{DD(LPR)}$  vs.  $V_{DD}$  (LSI clock source)

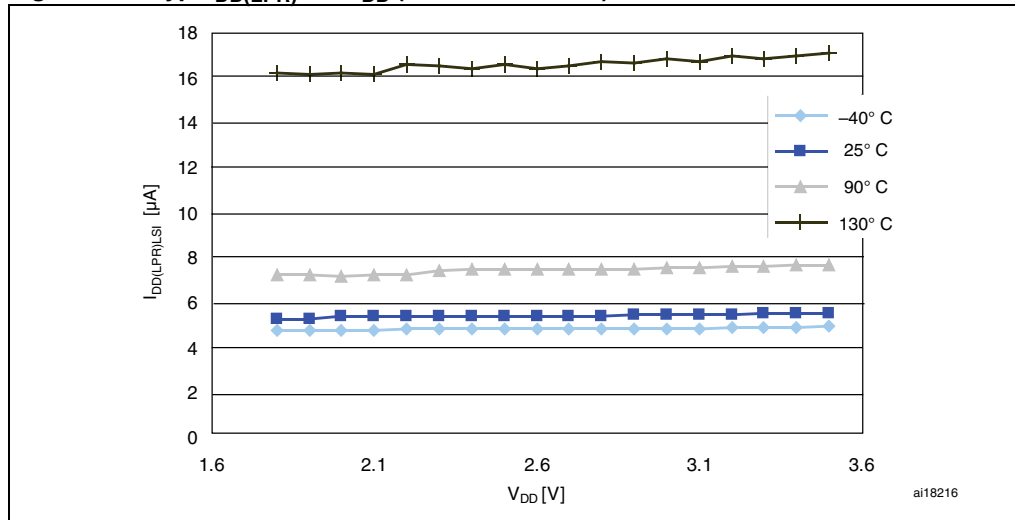

In the following table, data are based on characterization results, unless otherwise specified.

**Table 19. Total current consumption in Low power wait mode at  $V_{DD} = 1.65\text{ V}$  to  $3.6\text{ V}$**

Symbol	Parameter	Conditions <sup>(1)(2)</sup>		Typ	Max	Unit	
$I_{DD(LPW)}$	Supply current in Low power wait mode	LSI RC osc. (at 38 kHz)	all peripherals OFF	$T_A = -40\text{ }^\circ\text{C}$ to $25\text{ }^\circ\text{C}$	3	3.3	$\mu\text{A}$
				$T_A = 55\text{ }^\circ\text{C}$	3.3	3.6	
				$T_A = 85\text{ }^\circ\text{C}$	4.4	5	
				$T_A = 105\text{ }^\circ\text{C}$	6.7	8	
			$T_A = 125\text{ }^\circ\text{C}$	11	14		
			with TIM2 active <sup>(3)</sup>	$T_A = -40\text{ }^\circ\text{C}$ to $25\text{ }^\circ\text{C}$	3.4	3.7	
				$T_A = 55\text{ }^\circ\text{C}$	3.7	4	
				$T_A = 85\text{ }^\circ\text{C}$	4.8	5.4	
		$T_A = 105\text{ }^\circ\text{C}$		7	8.3		
		LSE external clock <sup>(4)</sup> (32.768 kHz)	all peripherals OFF	$T_A = -40\text{ }^\circ\text{C}$ to $25\text{ }^\circ\text{C}$	2.35	2.7	
				$T_A = 55\text{ }^\circ\text{C}$	2.42	2.82	
				$T_A = 85\text{ }^\circ\text{C}$	3.10	3.71	
				$T_A = 105\text{ }^\circ\text{C}$	4.36	5.7	
			$T_A = 125\text{ }^\circ\text{C}$	7.20	11		
			with TIM2 active <sup>(3)</sup>	$T_A = -40\text{ }^\circ\text{C}$ to $25\text{ }^\circ\text{C}$	2.46	2.75	
				$T_A = 55\text{ }^\circ\text{C}$	2.50	2.81	
$T_A = 85\text{ }^\circ\text{C}$	3.16			3.82			
$T_A = 105\text{ }^\circ\text{C}$	4.51	5.9					
$T_A = 125\text{ }^\circ\text{C}$	7.28	11					

1. No floating I/Os.
2.  $T_A > 85\text{ }^\circ\text{C}$  is valid only for devices with suffix 3 temperature range.
3. Timer 2 clock enabled and counter is running.
4. Oscillator bypassed (LSEBYP = 1 in CLK\_ECKCR). When configured for external crystal, the LSE consumption ( $I_{DD\text{ LSE}}$ ) must be added. Refer to [Table 28](#).

**Figure 15. Typ.  $I_{DD(LPW)}$  vs.  $V_{DD}$  (LSI clock source)**

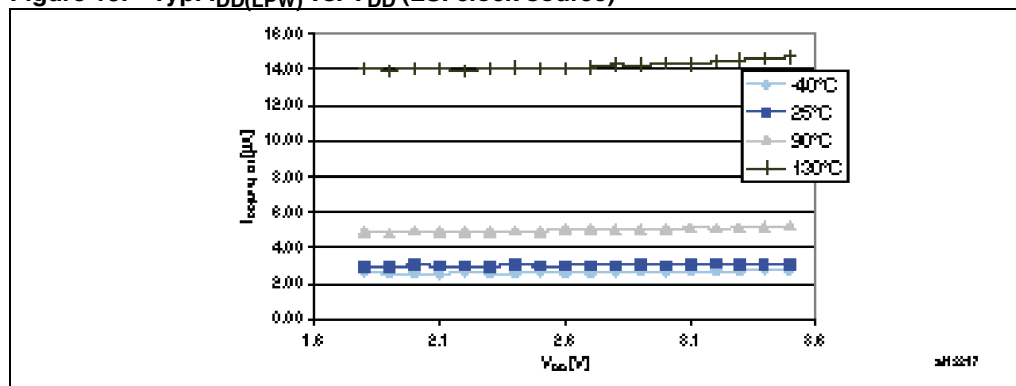

In the following table, data are based on characterization results, unless otherwise specified.

**Table 20. Total current consumption and timing in Active-halt mode at  $V_{DD} = 1.65\text{ V}$  to  $3.6\text{ V}$**

Symbol	Parameter	Conditions <sup>(1)(2)</sup>			Typ	Max	Unit
$I_{DD(AH)}$	Supply current in Active-halt mode	LSI RC (at 38 kHz)	$T_A = -40\text{ °C}$ to $25\text{ °C}$	0.9	2.1	$\mu\text{A}$	
			$T_A = 55\text{ °C}$	1.2	3		
			$T_A = 85\text{ °C}$	1.5	3.4		
			$T_A = 105\text{ °C}$	2.6	6.6		
			$T_A = 125\text{ °C}$	5.1	12		
		LSE external clock (32.768 kHz) <sup>(3)</sup>	$T_A = -40\text{ °C}$ to $25\text{ °C}$	0.5	1.2		
			$T_A = 55\text{ °C}$	0.62	1.4		
			$T_A = 85\text{ °C}$	0.88	2.1		
			$T_A = 105\text{ °C}$	2.1	4.85		
			$T_A = 125\text{ °C}$	4.8	11		
$I_{DD(WUFAH)}$	Supply current during wakeup time from Active-halt mode (using HSI)				2.4		mA
$t_{WU\_HSI(AH)}$ <sup>(4)(5)</sup>	Wakeup time from Active-halt mode to Run mode (using HSI)				4.7	7	$\mu\text{s}$
$t_{WU\_LSI(AH)}$ <sup>(4)(5)</sup>	Wakeup time from Active-halt mode to Run mode (using LSI)				150		$\mu\text{s}$

1. No floating I/O, unless otherwise specified.
2.  $T_A > 85\text{ °C}$  is valid only for devices with suffix 3 temperature range.
3. Oscillator bypassed (LSEBYP = 1 in CLK\_ECKCR). When configured for external crystal, the LSE consumption ( $I_{DD\ LSE}$ ) must be added. Refer to [Table 28](#)
4. Wakeup time until start of interrupt vector fetch.  
The first word of interrupt routine is fetched 4 CPU cycles after  $t_{WU}$ .
5. ULP=0 or ULP=1 and FWU=1 in the PWR\_CSR2 register.

**Table 21. Typical current consumption in Active-halt mode, RTC clocked by LSE external crystal**

Symbol	Parameter	Condition <sup>(1)</sup>		Typ	Unit
$I_{DD(AH)}$ <sup>(2)</sup>	Supply current in Active-halt mode	$V_{DD} = 1.8\text{ V}$	LSE	1.15	$\mu\text{A}$
			LSE/32 <sup>(3)</sup>	1.05	
		$V_{DD} = 3\text{ V}$	LSE	1.30	
			LSE/32 <sup>(3)</sup>	1.20	
		$V_{DD} = 3.6\text{ V}$	LSE	1.45	
			LSE/32 <sup>(3)</sup>	1.35	

1. No floating I/O, unless otherwise specified.
2. Based on measurements on bench with 32.768 kHz external crystal oscillator.
3. RTC clock is LSE divided by 32.

In the following table, data are based on characterization results, unless otherwise specified.

**Table 22. Total current consumption and timing in Halt mode at  $V_{DD} = 1.65$  to  $3.6$  V**

Symbol	Parameter	Condition <sup>(1)(2)</sup>	Typ	Max	Unit
$I_{DD(Halt)}$	Supply current in Halt mode (Ultra low power ULP bit =1 in the PWR_CSR2 register)	$T_A = -40$ °C to $25$ °C	350	1400 <sup>(3)</sup>	nA
		$T_A = 55$ °C	580	2000	
		$T_A = 85$ °C	1160	2800 <sup>(3)</sup>	
		$T_A = 105$ °C	2560	6700 <sup>(3)</sup>	
				$T_A = 125$ °C	4.4
$I_{DD(WUHalt)}$	Supply current during wakeup time from Halt mode (using HSI)		2.4		mA
$t_{WU\_HSI(Halt)}$ <sup>(4)(5)</sup>	Wakeup time from Halt to Run mode (using HSI)		4.7	7	$\mu$ s
$t_{WU\_LSI(Halt)}$ <sup>(4)(5)</sup>	Wakeup time from Halt mode to Run mode (using LSI)		150		$\mu$ s

- $T_A = -40$  to  $125$  °C, no floating I/O, unless otherwise specified.
- $T_A > 85$  °C is valid only for devices with suffix 3 temperature range.
- Tested in production.
- ULP=0 or ULP=1 and FWU=1 in the PWR\_CSR2 register.
- Wakeup time until start of interrupt vector fetch.  
The first word of interrupt routine is fetched 4 CPU cycles after  $t_{WU}$ .

## Current consumption of on-chip peripherals

Table 23. Peripheral current consumption

Symbol	Parameter	Typ. $V_{DD} = 3.0\text{ V}$	Unit	
$I_{DD}(TIM2)$	TIM2 supply current <sup>(1)</sup>	8	$\mu\text{A}/\text{MHz}$	
$I_{DD}(TIM3)$	TIM3 supply current <sup>(1)</sup>	8		
$I_{DD}(TIM4)$	TIM4 timer supply current <sup>(1)</sup>	3		
$I_{DD}(USART1)$	USART1 supply current <sup>(2)</sup>	6		
$I_{DD}(SPI1)$	SPI1 supply current <sup>(2)</sup>	3		
$I_{DD}(I2C1)$	I <sup>2</sup> C1 supply current <sup>(2)</sup>	5		
$I_{DD}(DMA1)$	DMA1 supply current <sup>(2)</sup>	3		
$I_{DD}(WWDG)$	WWDG supply current <sup>(2)</sup>	2		
$I_{DD}(ALL)$	Peripherals ON <sup>(3)</sup>	38	$\mu\text{A}/\text{MHz}$	
$I_{DD}(ADC1)$	ADC1 supply current <sup>(4)</sup>	1500	$\mu\text{A}$	
$I_{DD}(COMP1)$	Comparator 1 supply current <sup>(5)</sup>	0.160		
$I_{DD}(COMP2)$	Comparator 2 supply current <sup>(5)</sup>	Slow mode		2
		Fast mode		5
$I_{DD}(PVD/BOR)$	Power voltage detector and brownout Reset unit supply current <sup>(6)</sup>	2.6		
$I_{DD}(BOR)$	Brownout Reset unit supply current <sup>(6)</sup>	2.4		
$I_{DD}(IDWDG)$	Independent watchdog supply current	including LSI supply current		0.45
		excluding LSI supply current	0.05	

1. Data based on a differential  $I_{DD}$  measurement between all peripherals OFF and a timer counter running at 16 MHz. The CPU is in Wait mode in both cases. No IC/OC programmed, no I/O pins toggling. Not tested in production.
2. Data based on a differential  $I_{DD}$  measurement between the on-chip peripheral in reset configuration and not clocked and the on-chip peripheral when clocked and not kept under reset. The CPU is in Wait mode in both cases. No I/O pins toggling. Not tested in production.
3. Peripherals listed above the  $I_{DD}(ALL)$  parameter ON: TIM2, TIM3, TIM4, USART1, SPI1, I2C1, DMA1, WWDG.
4. Data based on a differential  $I_{DD}$  measurement between ADC1 in reset configuration and continuous ADC1 conversion.
5. Data based on a differential  $I_{DD}$  measurement between COMP1 or COMP2 in reset configuration and COMP1 or COMP2 enabled with static inputs. Supply current of internal reference voltage excluded.
6. Including supply current of internal reference voltage.



**Table 24. Current consumption under external reset**

Symbol	Parameter	Conditions	Typ	Unit	
$I_{DD(RST)}$	Supply current under external reset <sup>(1)</sup>	All pins are externally tied to $V_{DD}$	$V_{DD} = 1.8\text{ V}$	48	$\mu\text{A}$
			$V_{DD} = 3\text{ V}$	76	
			$V_{DD} = 3.6\text{ V}$	91	

1. All pins except PA0, PB0 and PB4 are floating under reset. PA0, PB0 and PB4 are configured with pull-up under reset.

### 7.3.4 Clock and timing characteristics

#### HSE external clock (HSEBYP = 1 in CLK\_ECKCR)

Subject to general operating conditions for  $V_{DD}$  and  $T_A$ .

**Table 25. HSE external clock characteristics**

Symbol	Parameter	Conditions	Min	Typ	Max	Unit
$f_{HSE\_ext}$	External clock source frequency <sup>(1)</sup>		1		16	MHz
$V_{HSEH}$	OSC_IN input pin high level voltage		$0.7 \times V_{DD}$		$V_{DD}$	V
$V_{HSEL}$	OSC_IN input pin low level voltage		$V_{SS}$		$0.3 \times V_{DD}$	
$C_{in(HSE)}$	OSC_IN input capacitance <sup>(1)</sup>			2.6		pF
$I_{LEAK\_HSE}$	OSC_IN input leakage current	$V_{SS} < V_{IN} < V_{DD}$			$\pm 1$	$\mu\text{A}$

1. Data guaranteed by Design, not tested in production.

#### LSE external clock (LSEBYP=1 in CLK\_ECKCR)

Subject to general operating conditions for  $V_{DD}$  and  $T_A$ .

**Table 26. LSE external clock characteristics**

Symbol	Parameter	Min	Typ	Max	Unit
$f_{LSE\_ext}$	External clock source frequency <sup>(1)</sup>		32.768		kHz
$V_{LSEH}^{(2)}$	OSC32_IN input pin high level voltage	$0.7 \times V_{DD}$		$V_{DD}$	V
$V_{LSEL}^{(2)}$	OSC32_IN input pin low level voltage	$V_{SS}$		$0.3 \times V_{DD}$	
$C_{in(LSE)}$	OSC32_IN input capacitance <sup>(1)</sup>		0.6		pF
$I_{LEAK\_LSE}$	OSC32_IN input leakage current			$\pm 1$	$\mu\text{A}$

1. Data guaranteed by Design, not tested in production.

2. Data based on characterization results, not tested in production.

### HSE crystal/ceramic resonator oscillator

The HSE clock can be supplied with a 1 to 16 MHz crystal/ceramic resonator oscillator. All the information given in this paragraph is based on characterization results with specified typical external components. In the application, the resonator and the load capacitors have to be placed as close as possible to the oscillator pins in order to minimize output distortion and startup stabilization time. Refer to the crystal resonator manufacturer for more details (frequency, package, accuracy...).

**Table 27. HSE oscillator characteristics**

Symbol	Parameter	Conditions	Min	Typ	Max	Unit
$f_{HSE}$	High speed external oscillator frequency		1		16	MHz
$R_F$	Feedback resistor			200		k $\Omega$
$C^{(1)}$	Recommended load capacitance <sup>(2)</sup>			20		pF
$I_{DD(HSE)}$	HSE oscillator power consumption	$C = 20$ pF, $f_{OSC} = 16$ MHz			2.5 (startup) 0.7 (stabilized) <sup>(3)</sup>	mA
		$C = 10$ pF, $f_{OSC} = 16$ MHz			2.5 (startup) 0.46 (stabilized) <sup>(3)</sup>	
$g_m$	Oscillator transconductance		3.5 <sup>(3)</sup>			mA/V
$t_{SU(HSE)}$ <sup>(4)</sup>	Startup time	$V_{DD}$ is stabilized		1		ms

1.  $C=C_{L1}=C_{L2}$  is approximately equivalent to  $2 \times$  crystal  $C_{LOAD}$ .
2. The oscillator selection can be optimized in terms of supply current using a high quality resonator with small  $R_m$  value. Refer to crystal manufacturer for more details
3. Data guaranteed by Design. Not tested in production.
4.  $t_{SU(HSE)}$  is the startup time measured from the moment it is enabled (by software) to a stabilized 16 MHz oscillation. This value is measured for a standard crystal resonator and it can vary significantly with the crystal manufacturer.

**Figure 16. HSE oscillator circuit diagram**

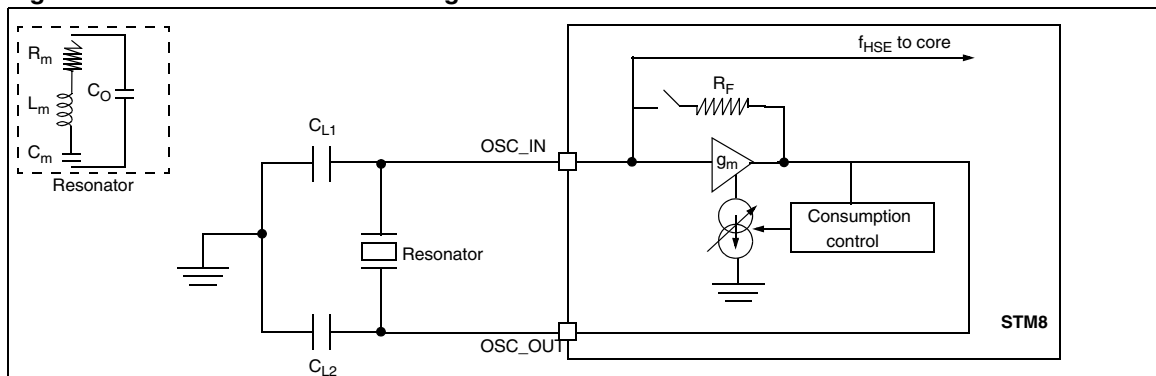

#### HSE oscillator critical $g_m$ formula

$$g_{m\text{crit}} = (2 \times \pi \times f_{HSE})^2 \times R_m (2C_o + C)^2$$

$R_m$ : Motional resistance (see crystal specification),  $L_m$ : Motional inductance (see crystal specification),  
 $C_m$ : Motional capacitance (see crystal specification),  $C_o$ : Shunt capacitance (see crystal specification),  
 $C_{L1}=C_{L2}=C$ : Grounded external capacitance  
 $g_m \gg g_{m\text{crit}}$

### LSE crystal/ceramic resonator oscillator

The LSE clock can be supplied with a 32.768 kHz crystal/ceramic resonator oscillator. All the information given in this paragraph is based on characterization results with specified typical external components. In the application, the resonator and the load capacitors have to be placed as close as possible to the oscillator pins in order to minimize output distortion and startup stabilization time. Refer to the crystal resonator manufacturer for more details (frequency, package, accuracy...).

**Table 28. LSE oscillator characteristics**

Symbol	Parameter	Conditions	Min	Typ	Max	Unit
$f_{LSE}$	Low speed external oscillator frequency			32.768		kHz
$R_F$	Feedback resistor	$\Delta V = 200 \text{ mV}$		1.2		$M\Omega$
$C^{(1)}$	Recommended load capacitance <sup>(2)</sup>			8		pF
$I_{DD(LSE)}$	LSE oscillator power consumption				1.4 <sup>(3)</sup>	$\mu\text{A}$
		$V_{DD} = 1.8 \text{ V}$		450		nA
		$V_{DD} = 3 \text{ V}$		600		
	$V_{DD} = 3.6 \text{ V}$		750			
$g_m$	Oscillator transconductance		3 <sup>(3)</sup>			$\mu\text{A/V}$
$t_{SU(LSE)}^{(4)}$	Startup time	$V_{DD}$ is stabilized		1		s

1.  $C=C_{L1}=C_{L2}$  is approximately equivalent to 2 x crystal  $C_{LOAD}$ .
2. The oscillator selection can be optimized in terms of supply current using a high quality resonator with a small  $R_m$  value. Refer to crystal manufacturer for more details.
3. Data guaranteed by Design. Not tested in production.
4.  $t_{SU(LSE)}$  is the startup time measured from the moment it is enabled (by software) to a stabilized 32.768 kHz oscillation. This value is measured for a standard crystal resonator and it can vary significantly with the crystal manufacturer.

**Figure 17. LSE oscillator circuit diagram**

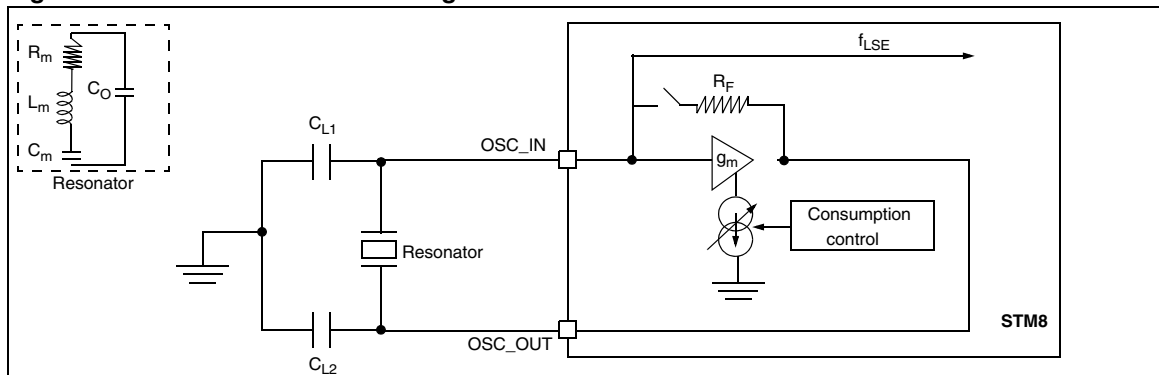

### Internal clock sources

Subject to general operating conditions for  $V_{DD}$ , and  $T_A$ .

#### High speed internal RC oscillator (HSI)

In the following table, data are based on characterization results, not tested in production, unless otherwise specified.

**Table 29. HSI oscillator characteristics**

Symbol	Parameter	Conditions <sup>(1)(2)</sup>	Min	Typ	Max	Unit
$f_{HSI}$	Frequency	$V_{DD} = 3.0\text{ V}$		16		MHz
$ACC_{HSI}$	Accuracy of HSI oscillator (factory calibrated)	$V_{DD} = 3.0\text{ V}, T_A = 25\text{ °C}$	-1 <sup>(3)</sup>		1 <sup>(3)</sup>	%
		$V_{DD} = 3.0\text{ V}, 0\text{ °C} \leq T_A \leq 55\text{ °C}$	-1.5		1.5	%
		$V_{DD} = 3.0\text{ V}, -10\text{ °C} \leq T_A \leq 70\text{ °C}$	-2		2	%
		$V_{DD} = 3.0\text{ V}, -10\text{ °C} \leq T_A \leq 85\text{ °C}$	-2.5		2	%
		$V_{DD} = 3.0\text{ V}, -10\text{ °C} \leq T_A \leq 125\text{ °C}$	-4.5		2	%
		$1.65\text{ V} \leq V_{DD} \leq 3.6\text{ V}, -40\text{ °C} \leq T_A \leq 125\text{ °C}$	-4.5		3	%
TRIM	HSI user trimming step <sup>(4)</sup>	Trimming code $\neq$ multiple of 16		0.4	0.7	%
		Trimming code = multiple of 16			$\pm 1.5$	%
$t_{su(HSI)}$	HSI oscillator setup time (wakeup time)			3.7	6 <sup>(5)</sup>	$\mu\text{s}$
$I_{DD(HSI)}$	HSI oscillator power consumption			100	140 <sup>(5)</sup>	$\mu\text{A}$

- $V_{DD} = 3.0\text{ V}, T_A = -40\text{ to }125\text{ °C}$  unless otherwise specified.
- $T_A > 85\text{ °C}$  is valid only for devices with suffix 3 temperature range.
- Tested in production.
- The trimming step differs depending on the trimming code. It is usually negative on the codes which are multiples of 16 (0x00, 0x10, 0x20, 0x30...0xE0). Refer to the AN3101 "STM8L15x internal RC oscillator calibration" application note for more details.
- Guaranteed by design, not tested in production.

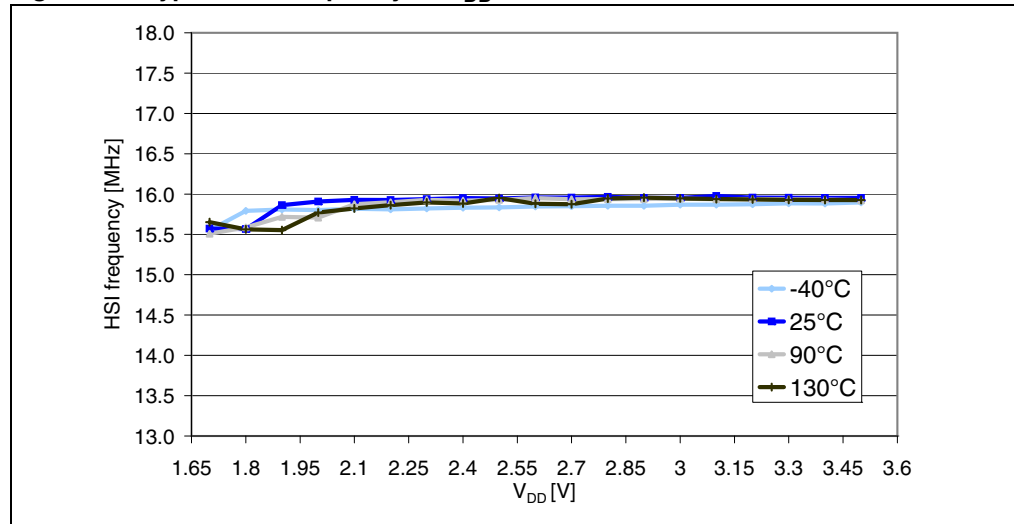
Figure 18. Typical HSI frequency vs  $V_{DD}$ **Low speed internal RC oscillator (LSI)**

In the following table, data are based on characterization results, not tested in production.

Table 30. LSI oscillator characteristics

Symbol	Parameter <sup>(1)</sup>	Conditions <sup>(1)</sup>	Min	Typ	Max	Unit
$f_{LSI}$	Frequency		26	38	56	kHz
$t_{su(LSI)}$	LSI oscillator wakeup time				200 <sup>(2)</sup>	$\mu$ s
$I_{DD(LSI)}$	LSI oscillator frequency drift <sup>(3)</sup>	$0\text{ }^{\circ}\text{C} \leq T_A \leq 85\text{ }^{\circ}\text{C}$	-12		11	%

1.  $V_{DD} = 1.65\text{ V to }3.6\text{ V}$ ,  $T_A = -40\text{ to }125\text{ }^{\circ}\text{C}$  unless otherwise specified.

2. Guaranteed by design, not tested in production.

3. This is a deviation for an individual part, once the initial frequency has been measured.

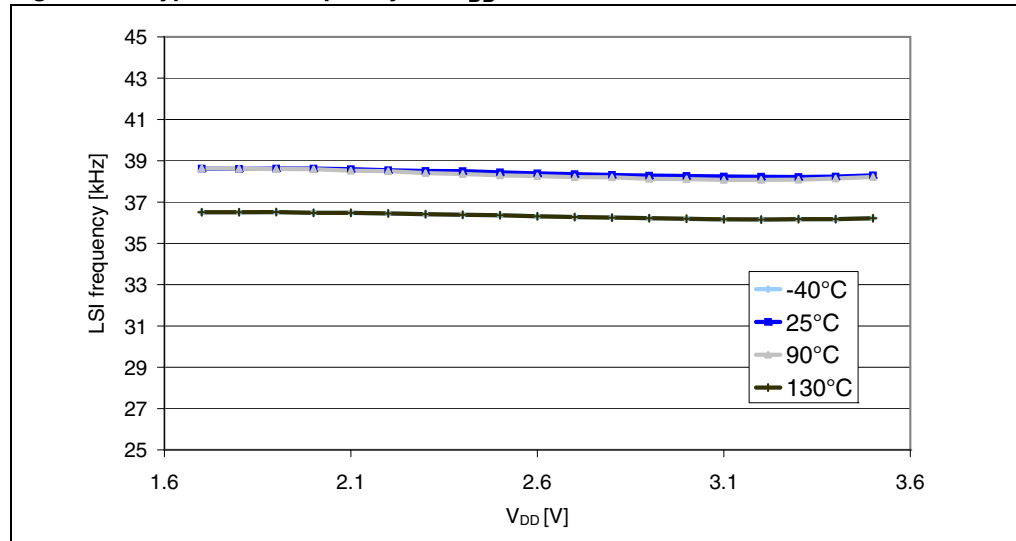
Figure 19. Typical LSI frequency vs.  $V_{DD}$ 

### 7.3.5 Memory characteristics

$T_A = -40$  to  $125$  °C unless otherwise specified.

**Table 31. RAM and hardware registers**

Symbol	Parameter	Conditions	Min	Typ	Max	Unit
$V_{RM}$	Data retention mode <sup>(1)</sup>	Halt mode (or Reset)	1.65			V

1. Minimum supply voltage without losing data stored in RAM (in Halt mode or under Reset) or in hardware registers (only in Halt mode). Guaranteed by characterization, not tested in production.

### Flash memory

**Table 32. Flash program and data EEPROM memory**

Symbol	Parameter	Conditions	Min	Typ	Max <sup>(1)</sup>	Unit
$V_{DD}$	Operating voltage (all modes, read/write/erase)	$f_{SYSCLK} = 16$ MHz	1.65		3.6	V
$t_{prog}$	Programming time for 1 or 64 bytes (block) erase/write cycles (on programmed byte)			6		ms
	Programming time for 1 to 64 bytes (block) write cycles (on erased byte)			3		ms
$I_{prog}$	Programming/ erasing consumption	$T_A = +25$ °C, $V_{DD} = 3.0$ V		0.7		mA
		$T_A = +25$ °C, $V_{DD} = 1.8$ V				
$t_{RET}^{(2)}$	Data retention (program memory) after 10000 erase/write cycles at $T_A = -40$ to $+85$ °C (3 and 6 suffix)	$T_{RET} = +85$ °C	30 <sup>(1)</sup>			years
	Data retention (program memory) after 10000 erase/write cycles at $T_A = -40$ to $+125$ °C (3 suffix)	$T_{RET} = +125$ °C	5 <sup>(1)</sup>			
	Data retention (data memory) after 300000 erase/write cycles at $T_A = -40$ to $+85$ °C (3 and 6 suffix)	$T_{RET} = +85$ °C	30 <sup>(1)</sup>			
	Data retention (data memory) after 300000 erase/write cycles at $T_A = -40$ to $+125$ °C (3 suffix)	$T_{RET} = +125$ °C	5 <sup>(1)</sup>			
$N_{RW}^{(3)}$	Erase/write cycles (program memory)	$T_A = -40$ to $+85$ °C (3 and 6 suffix), $T_A = -40$ to $+105$ °C (3 suffix) or $T_A = -40$ to $+125$ °C (3 suffix)	10 <sup>(1)</sup>			kcycles
	Erase/write cycles (data memory)		300 <sup>(1)</sup> <sup>(4)</sup>			

1. Data based on characterization results, not tested in production.

2. Conforming to JEDEC JESD22a117

3. The physical granularity of the memory is 4 bytes, so cycling is performed on 4 bytes even when a write/erase operation addresses a single byte.

4. Data based on characterization performed on the whole data memory.

### 7.3.6 I/O current injection characteristics

As a general rule, current injection to the I/O pins, due to external voltage below  $V_{SS}$  or above  $V_{DD}$  (for standard pins) should be avoided during normal product operation. However, in order to give an indication of the robustness of the microcontroller in cases when abnormal injection accidentally happens, susceptibility tests are performed on a sample basis during device characterization.

#### Functional susceptibility to I/O current injection

While a simple application is executed on the device, the device is stressed by injecting current into the I/O pins programmed in floating input mode. While current is injected into the I/O pin, one at a time, the device is checked for functional failures.

The failure is indicated by an out of range parameter: ADC1 error, out of spec current injection on adjacent pins or other functional failure (for example reset, oscillator frequency deviation, etc.).

The test results are given in the following table.

**Table 33. I/O current injection susceptibility**

Symbol	Description	Functional susceptibility		Unit
		Negative injection	Positive injection	
$I_{INJ}$	Injected current on true open-drain pins (PC0 and PC1)	-5	+0	mA
	Injected current on all five-volt tolerant pins	-5	+0	
	Injected current on all 3.6 V tolerant pins	-5	+0	
	Injected current on any other pin	-5	+5	

### 7.3.7 I/O port pin characteristics

#### General characteristics

Subject to general operating conditions for  $V_{DD}$  and  $T_A$  unless otherwise specified. All unused pins must be kept at a fixed voltage: using the output mode of the I/O for example or an external pull-up or pull-down resistor.



Table 34. I/O static characteristics

Symbol	Parameter	Conditions <sup>(1)</sup>	Min	Typ	Max	Unit
V <sub>IL</sub>	Input low level voltage <sup>(2)</sup>	Input voltage on true open-drain pins (PC0 and PC1)	V <sub>SS</sub> -0.3		0.3 x V <sub>DD</sub>	V
		Input voltage on five-volt tolerant pins (PA7 and PE0)	V <sub>SS</sub> -0.3		0.3 x V <sub>DD</sub>	
		Input voltage on 3.6 V tolerant pins	V <sub>SS</sub> -0.3		0.3 x V <sub>DD</sub>	
		Input voltage on any other pin	V <sub>SS</sub> -0.3		0.3 x V <sub>DD</sub>	
V <sub>IH</sub>	Input high level voltage <sup>(2)</sup>	Input voltage on true open-drain pins (PC0 and PC1) with V <sub>DD</sub> < 2 V	0.70 x V <sub>DD</sub>		5.2	V
		Input voltage on true open-drain pins (PC0 and PC1) with V <sub>DD</sub> ≥ 2 V			5.5	
		Input voltage on five-volt tolerant pins (PA7 and PE0) with V <sub>DD</sub> < 2 V	0.70 x V <sub>DD</sub>		5.2	
		Input voltage on five-volt tolerant pins (PA7 and PE0) with V <sub>DD</sub> ≥ 2 V			5.5	
		Input voltage on 3.6 V tolerant pins			3.6	
		Input voltage on any other pin	0.70 x V <sub>DD</sub>		V <sub>DD</sub> +0.3	
V <sub>hys</sub>	Schmitt trigger voltage hysteresis <sup>(3)</sup>	I/Os		200		mV
		True open drain I/Os		200		
I <sub>lkg</sub>	Input leakage current <sup>(4)</sup>	V <sub>SS</sub> ≤ V <sub>IN</sub> ≤ V <sub>DD</sub> High sink I/Os	-	-	50 <sup>(5)</sup>	nA
		V <sub>SS</sub> ≤ V <sub>IN</sub> ≤ V <sub>DD</sub> True open drain I/Os	-	-	200 <sup>(5)</sup>	
		V <sub>SS</sub> ≤ V <sub>IN</sub> ≤ V <sub>DD</sub> PA0 with high sink LED driver capability	-	-	200 <sup>(5)</sup>	
R <sub>PU</sub>	Weak pull-up equivalent resistor <sup>(2)(6)</sup>	V <sub>IN</sub> =V <sub>SS</sub>	30	45	60	kΩ
C <sub>IO</sub>	I/O pin capacitance			5		pF

1. V<sub>DD</sub> = 3.0 V, T<sub>A</sub> = -40 to 125 °C unless otherwise specified.

2. Data based on characterization results, not tested in production.

3. Hysteresis voltage between Schmitt trigger switching levels. Based on characterization results, not tested.

4. The max. value may be exceeded if negative current is injected on adjacent pins.

5. Not tested in production.

6. R<sub>PU</sub> pull-up equivalent resistor based on a resistive transistor (corresponding I<sub>PU</sub> current characteristics described in [Figure 23](#)).

Figure 20. Typical  $V_{IL}$  and  $V_{IH}$  vs  $V_{DD}$  (high sink I/Os)

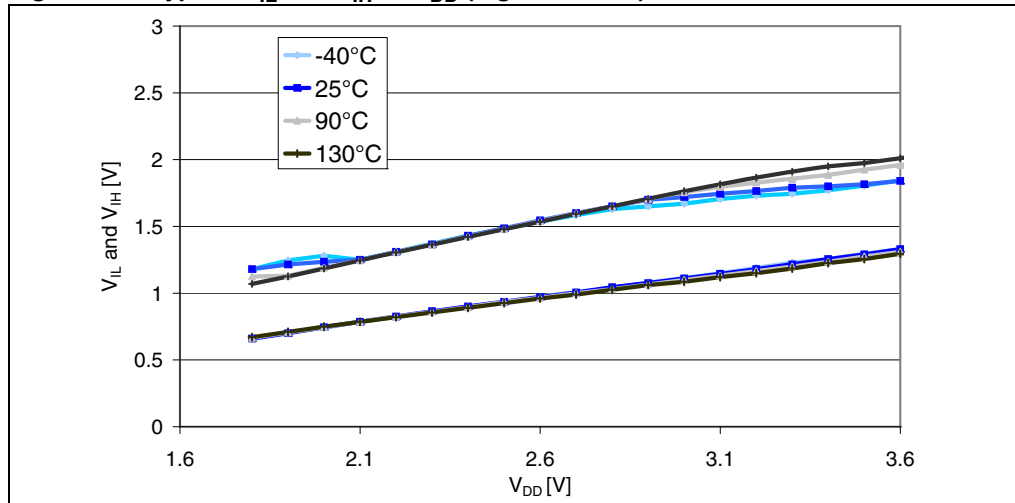

Figure 21. Typical  $V_{IL}$  and  $V_{IH}$  vs  $V_{DD}$  (true open drain I/Os)

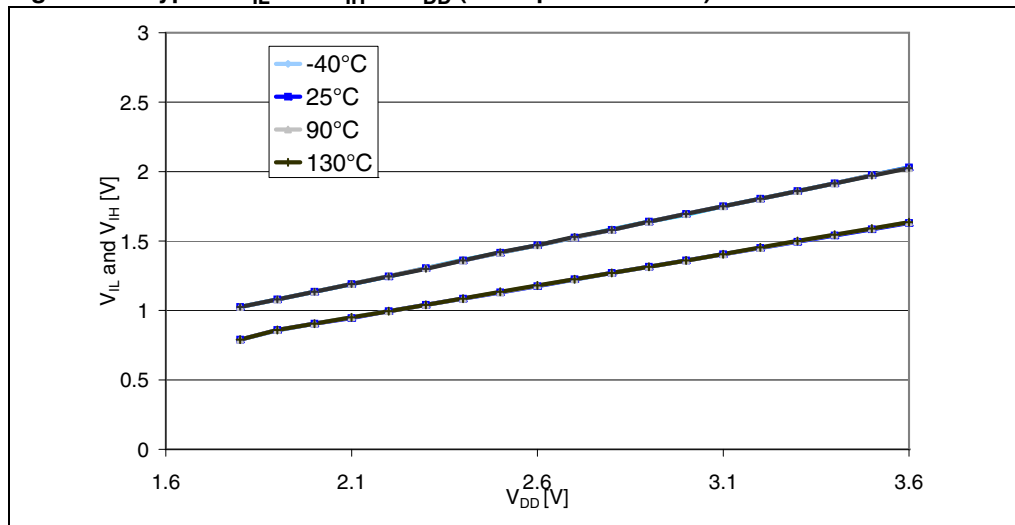

Figure 22. Typical pull-up resistance  $R_{PU}$  vs  $V_{DD}$  with  $V_{IN}=V_{SS}$

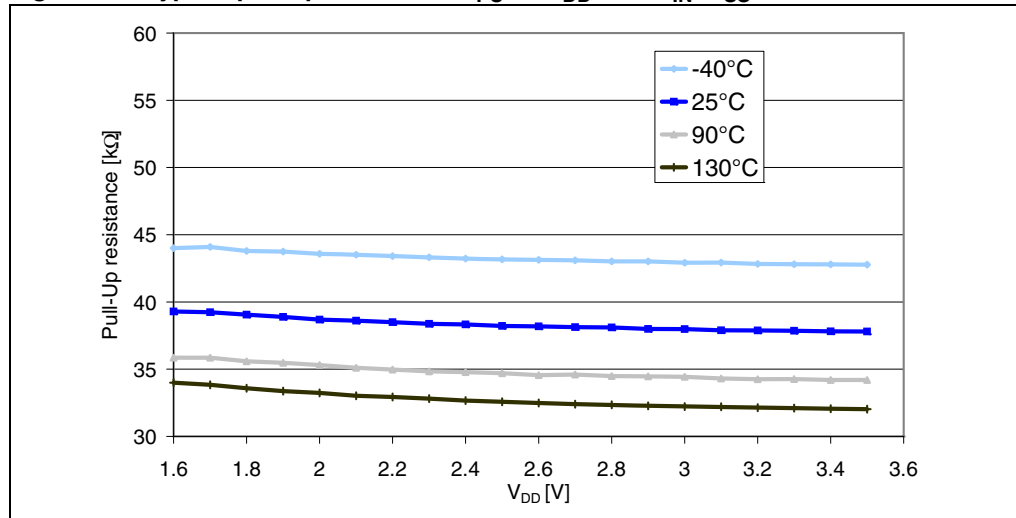
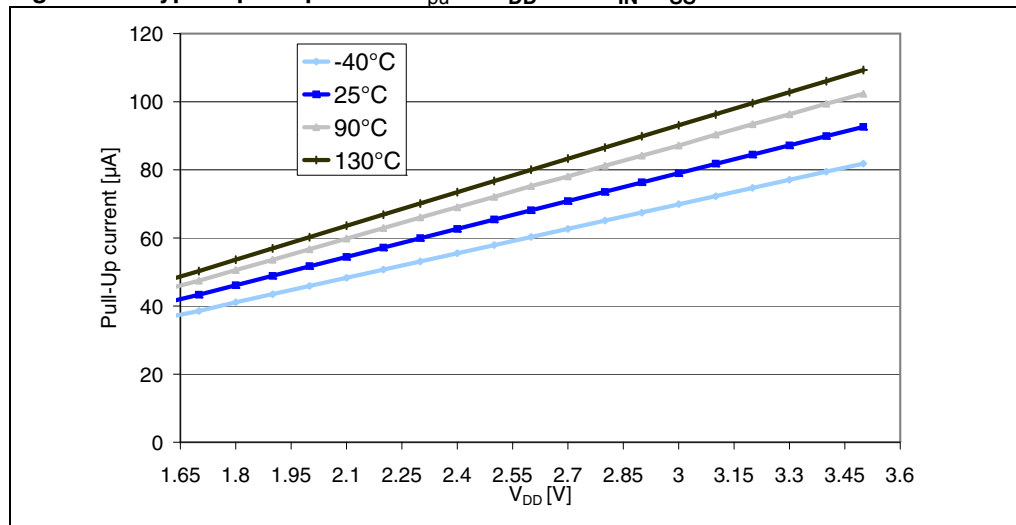

Figure 23. Typical pull-up current  $I_{PU}$  vs  $V_{DD}$  with  $V_{IN}=V_{SS}$



**Output driving current**

Subject to general operating conditions for  $V_{DD}$  and  $T_A$  unless otherwise specified.

**Table 35. Output driving current (high sink ports)**

I/O Type	Symbol	Parameter	Conditions	Min	Max	Unit
High sink	$V_{OL}^{(1)}$	Output low level voltage for an I/O pin	$I_{IO} = +2 \text{ mA}$ , $V_{DD} = 3.0 \text{ V}$		0.45	V
			$I_{IO} = +2 \text{ mA}$ , $V_{DD} = 1.8 \text{ V}$		0.45	V
			$I_{IO} = +10 \text{ mA}$ , $V_{DD} = 3.0 \text{ V}$		0.7	V
	$V_{OH}^{(2)}$	Output high level voltage for an I/O pin	$I_{IO} = -2 \text{ mA}$ , $V_{DD} = 3.0 \text{ V}$	$V_{DD}-0.45$		V
			$I_{IO} = -1 \text{ mA}$ , $V_{DD} = 1.8 \text{ V}$	$V_{DD}-0.45$		V
			$I_{IO} = -10 \text{ mA}$ , $V_{DD} = 3.0 \text{ V}$	$V_{DD}-0.7$		V

1. The  $I_{IO}$  current sunk must always respect the absolute maximum rating specified in [Table 12](#) and the sum of  $I_{IO}$  (I/O ports and control pins) must not exceed  $I_{VSS}$ .
2. The  $I_{IO}$  current sourced must always respect the absolute maximum rating specified in [Table 12](#) and the sum of  $I_{IO}$  (I/O ports and control pins) must not exceed  $I_{VDD}$ .

**Table 36. Output driving current (true open drain ports)**

I/O Type	Symbol	Parameter	Conditions	Min	Max	Unit
Open drain	$V_{OL}^{(1)}$	Output low level voltage for an I/O pin	$I_{IO} = +3 \text{ mA}$ , $V_{DD} = 3.0 \text{ V}$		0.45	V
			$I_{IO} = +1 \text{ mA}$ , $V_{DD} = 1.8 \text{ V}$		0.45	

1. The  $I_{IO}$  current sunk must always respect the absolute maximum rating specified in [Table 12](#) and the sum of  $I_{IO}$  (I/O ports and control pins) must not exceed  $I_{VSS}$ .

**Table 37. Output driving current (PA0 with high sink LED driver capability)**

I/O Type	Symbol	Parameter	Conditions	Min	Max	Unit
$\overline{\text{PA0}}$	$V_{OL}^{(1)}$	Output low level voltage for an I/O pin	$I_{IO} = +20 \text{ mA}$ , $V_{DD} = 2.0 \text{ V}$		0.45	V

1. The  $I_{IO}$  current sunk must always respect the absolute maximum rating specified in [Table 12](#) and the sum of  $I_{IO}$  (I/O ports and control pins) must not exceed  $I_{VSS}$ .

Figure 24. Typ.  $V_{OL}$  @  $V_{DD} = 3.0\text{ V}$  (high sink ports)

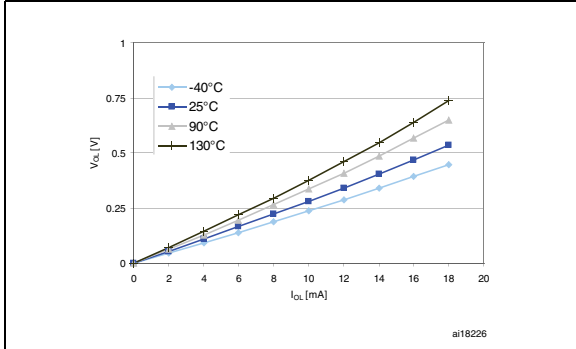

Figure 25. Typ.  $V_{OL}$  @  $V_{DD} = 1.8\text{ V}$  (high sink ports)

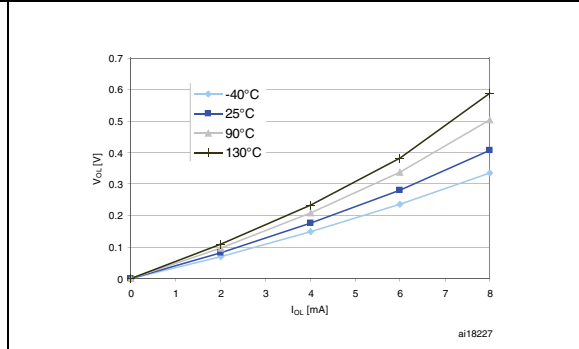

Figure 26. Typ.  $V_{OL}$  @  $V_{DD} = 3.0\text{ V}$  (true open drain ports)

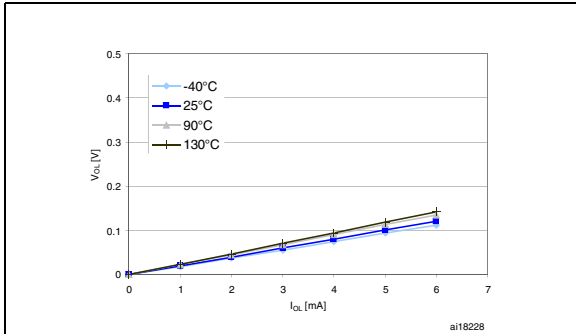

Figure 27. Typ.  $V_{OL}$  @  $V_{DD} = 1.8\text{ V}$  (true open drain ports)

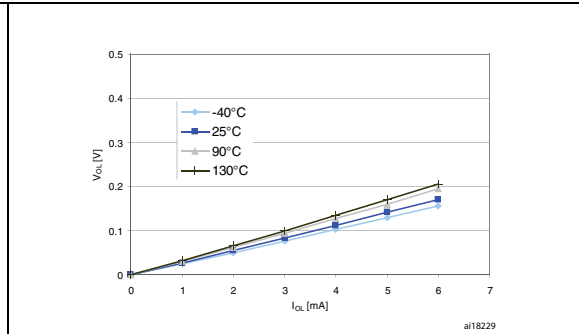

Figure 28. Typ.  $V_{DD} - V_{OH}$  @  $V_{DD} = 3.0\text{ V}$  (high sink ports)

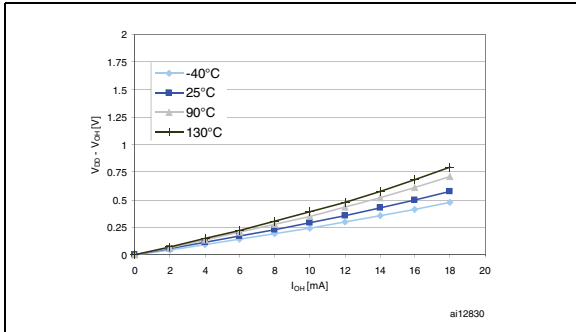
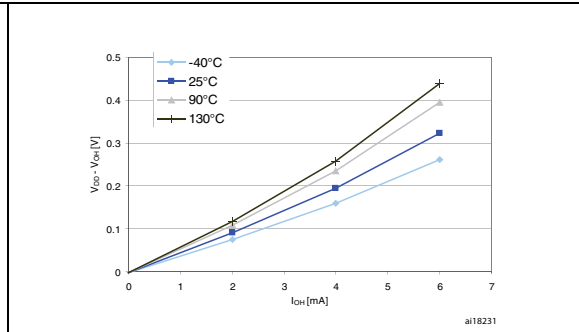

Figure 29. Typ.  $V_{DD} - V_{OH}$  @  $V_{DD} = 1.8\text{ V}$  (high sink ports)



**NRST pin**

Subject to general operating conditions for  $V_{DD}$  and  $T_A$  unless otherwise specified.

**Table 38. NRST pin characteristics**

Symbol	Parameter	Conditions	Min	Typ	Max	Unit
$V_{IL(NRST)}$	NRST input low level voltage <sup>(1)</sup>		$V_{SS}$		0.8	V
$V_{IH(NRST)}$	NRST input high level voltage <sup>(1)</sup>		1.4		$V_{DD}$	
$V_{OL(NRST)}$	NRST output low level voltage <sup>(1)</sup>	$I_{OL} = 2 \text{ mA}$ for $2.7 \text{ V} \leq V_{DD} \leq 3.6 \text{ V}$ $I_{OL} = 1.5 \text{ mA}$ for $V_{DD} < 2.7 \text{ V}$			0.4	
$V_{HYST}$	NRST input hysteresis <sup>(3)</sup>		$10\%V_{DD}$ (2)			mV
$R_{PU(NRST)}$	NRST pull-up equivalent resistor (1)		30	45	60	k $\Omega$
$V_{F(NRST)}$	NRST input filtered pulse <sup>(3)</sup>				50	ns
$V_{NF(NRST)}$	NRST input not filtered pulse <sup>(3)</sup>		300			

1. Data based on characterization results, not tested in production.

2. 200 mV min.

3. Data guaranteed by design, not tested in production.

**Figure 30. Typical NRST pull-up resistance  $R_{PU}$  vs  $V_{DD}$** 

Figure 31. Typical NRST pull-up current  $I_{DU}$  vs  $V_{DD}$



The reset network shown in [Figure 32](#) protects the device against parasitic resets. The user must ensure that the level on the NRST pin can go below the  $V_{IL(NRST)}$  max. level specified in [Table 38](#). Otherwise the reset is not taken into account internally.

For power consumption sensitive applications, the external reset capacitor value can be reduced to limit the charge/discharge current. If the NRST signal is used to reset the external circuitry, attention must be paid to the charge/discharge time of the external capacitor to fulfill the external devices reset timing conditions. The minimum recommended capacity is 10 nF.

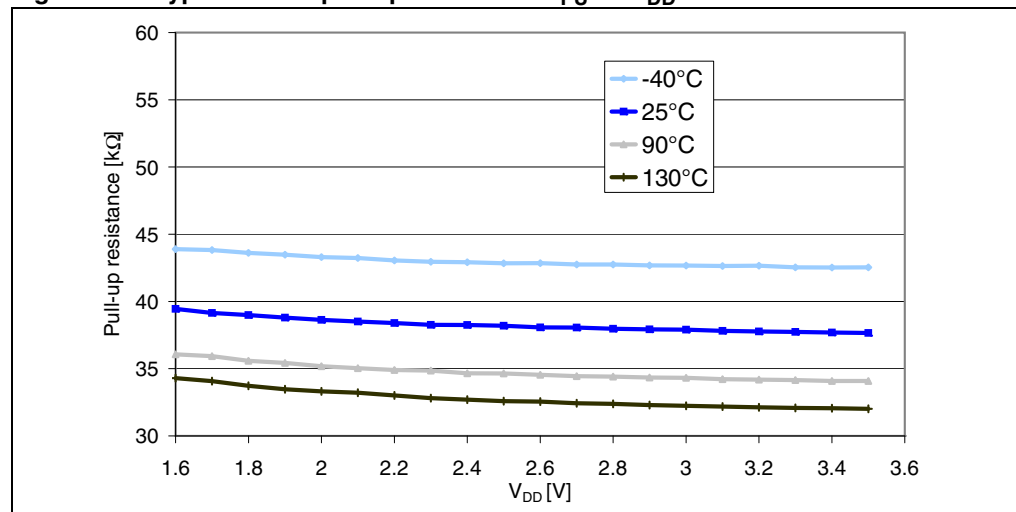
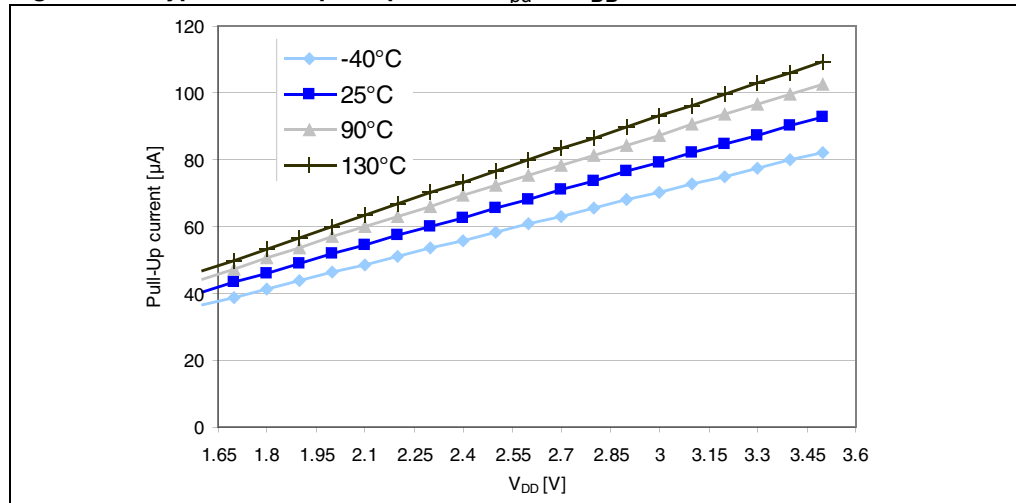
Figure 32. Recommended NRST pin configuration

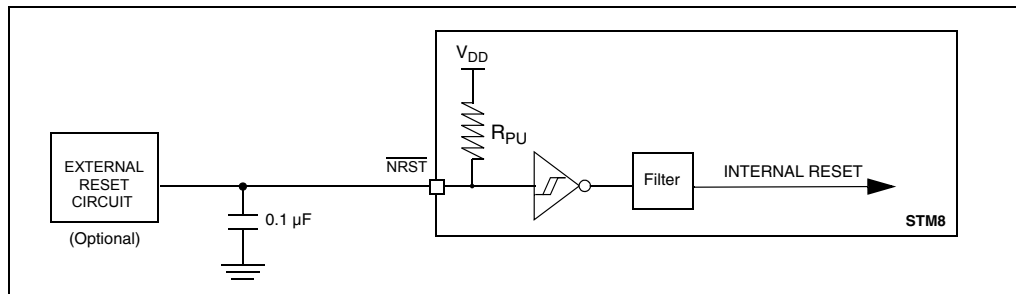

### 7.3.8 Communication interfaces

#### SPI1 - Serial peripheral interface

Unless otherwise specified, the parameters given in [Table 39](#) are derived from tests performed under ambient temperature,  $f_{\text{SYSCLK}}$  frequency and  $V_{\text{DD}}$  supply voltage conditions summarized in [Section 7.3.1](#). Refer to I/O port characteristics for more details on the input/output alternate function characteristics (NSS, SCK, MOSI, MISO).

**Table 39. SPI1 characteristics**

Symbol	Parameter	Conditions <sup>(1)</sup>	Min	Max	Unit
$f_{\text{SCK}}$ $1/t_{\text{c(SCK)}}$	SPI1 clock frequency	Master mode	0	8	MHz
		Slave mode	0	8	
$t_{\text{r(SCK)}}$ $t_{\text{f(SCK)}}$	SPI1 clock rise and fall time	Capacitive load: C = 30 pF	-	30	ns
$t_{\text{su(NSS)}}^{(2)}$	NSS setup time	Slave mode	$4 \times 1/f_{\text{SYSCLK}}$	-	
$t_{\text{h(NSS)}}^{(2)}$	NSS hold time	Slave mode	80	-	
$t_{\text{w(SCKH)}}^{(2)}$ $t_{\text{w(SCKL)}}^{(2)}$	SCK high and low time	Master mode, $f_{\text{MASTER}} = 8 \text{ MHz}$ , $f_{\text{SCK}} = 4 \text{ MHz}$	105	145	
$t_{\text{su(MI)}}^{(2)}$ $t_{\text{su(SI)}}^{(2)}$	Data input setup time	Master mode	30	-	
		Slave mode	3	-	
$t_{\text{h(MI)}}^{(2)}$ $t_{\text{h(SI)}}^{(2)}$	Data input hold time	Master mode	15	-	
		Slave mode	0	-	
$t_{\text{a(SO)}}^{(2)(3)}$	Data output access time	Slave mode	-	$3 \times 1/f_{\text{SYSCLK}}$	
$t_{\text{dis(SO)}}^{(2)(4)}$	Data output disable time	Slave mode	30	-	
$t_{\text{v(SO)}}^{(2)}$	Data output valid time	Slave mode (after enable edge)	-	60	
$t_{\text{v(MO)}}^{(2)}$	Data output valid time	Master mode (after enable edge)	-	20	
$t_{\text{h(SO)}}^{(2)}$	Data output hold time	Slave mode (after enable edge)	15	-	
$t_{\text{h(MO)}}^{(2)}$		Master mode (after enable edge)	1	-	

- Parameters are given by selecting 10 MHz I/O output frequency.
- Values based on design simulation and/or characterization results, and not tested in production.
- Min time is for the minimum time to drive the output and max time is for the maximum time to validate the data.
- Min time is for the minimum time to invalidate the output and max time is for the maximum time to put the data in Hi-Z.



Figure 33. SPI1 timing diagram - slave mode and CPHA=0

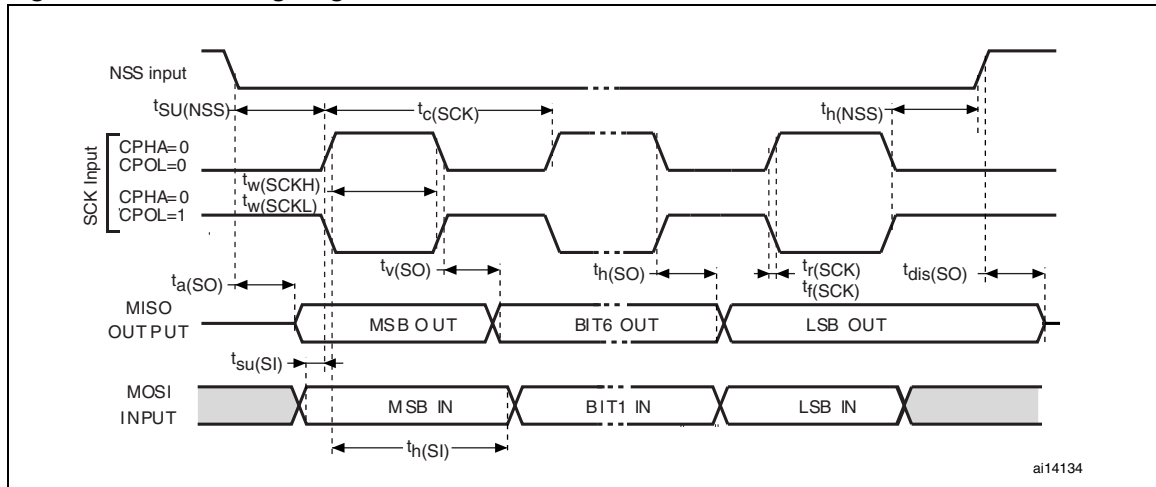
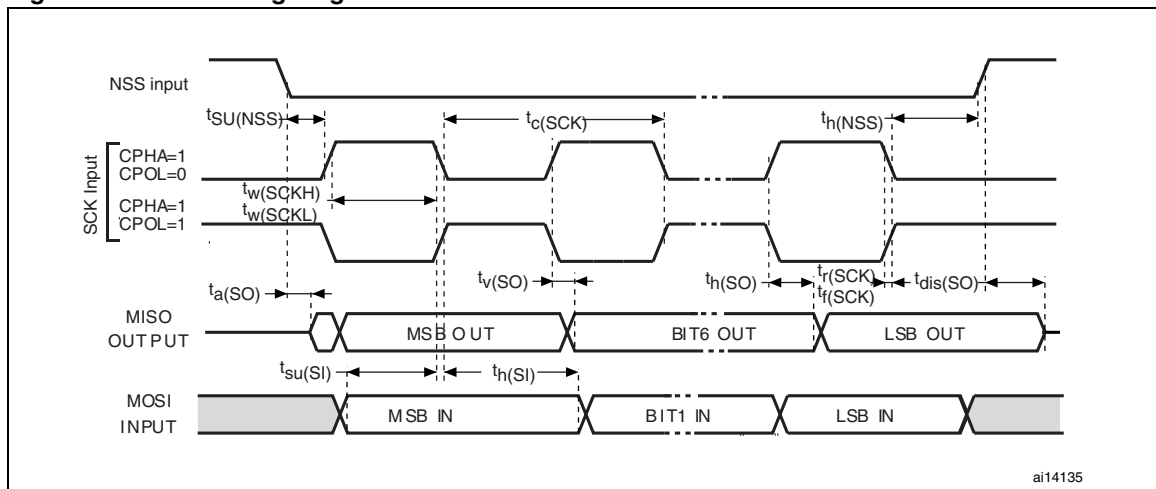
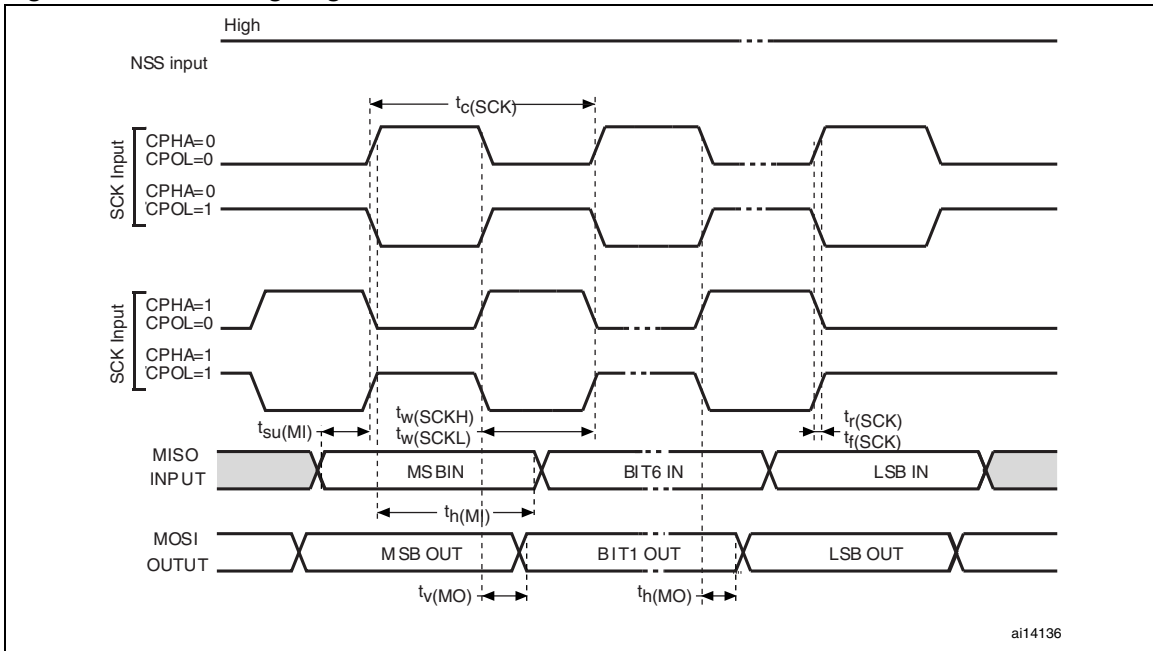

Figure 34. SPI1 timing diagram - slave mode and CPHA=1<sup>(1)</sup>



1. Measurement points are done at CMOS levels:  $0.3V_{DD}$  and  $0.7V_{DD}$ .

Figure 35. SPI1 timing diagram - master mode<sup>(1)</sup>



1. Measurement points are done at CMOS levels:  $0.3V_{DD}$  and  $0.7V_{DD}$ .

**I<sup>2</sup>C - Inter IC control interface**

Subject to general operating conditions for  $V_{DD}$ ,  $f_{SYSCLK}$ , and  $T_A$  unless otherwise specified.

The STM8L I<sup>2</sup>C interface (I2C1) meets the requirements of the Standard I<sup>2</sup>C communication protocol described in the following table with the restriction mentioned below:

Refer to I/O port characteristics for more details on the input/output alternate function characteristics (SDA and SCL).

**Table 40. I2C characteristics**

Symbol	Parameter	Standard mode I <sup>2</sup> C		Fast mode I <sup>2</sup> C <sup>(1)</sup>		Unit
		Min <sup>(2)</sup>	Max <sup>(2)</sup>	Min <sup>(2)</sup>	Max <sup>(2)</sup>	
$t_{w(SCLL)}$	SCL clock low time	4.7		1.3		$\mu\text{s}$
$t_{w(SCLH)}$	SCL clock high time	4.0		0.6		
$t_{su(SDA)}$	SDA setup time	250		100		ns
$t_h(SDA)$	SDA data hold time	0		0	900	
$t_r(SDA)$ $t_r(SCL)$	SDA and SCL rise time		1000		300	
$t_f(SDA)$ $t_f(SCL)$	SDA and SCL fall time		300		300	
$t_h(STA)$	START condition hold time	4.0		0.6		$\mu\text{s}$
$t_{su(STA)}$	Repeated START condition setup time	4.7		0.6		
$t_{su(STO)}$	STOP condition setup time	4.0		0.6		$\mu\text{s}$
$t_w(STO:STA)$	STOP to START condition time (bus free)	4.7		1.3		$\mu\text{s}$
$C_b$	Capacitive load for each bus line		400		400	pF

1.  $f_{SYSCLK}$  must be at least equal to 8 MHz to achieve max fast I<sup>2</sup>C speed (400 kHz).

2. Data based on standard I<sup>2</sup>C protocol requirement, not tested in production.

**Note:** *For speeds around 200 kHz, the achieved speed can have  $\pm 5\%$  tolerance  
For other speed ranges, the achieved speed can have  $\pm 2\%$  tolerance  
The above variations depend on the accuracy of the external components used.*

Figure 36. Typical application with I<sup>2</sup>C bus and timing diagram <sup>1)</sup>

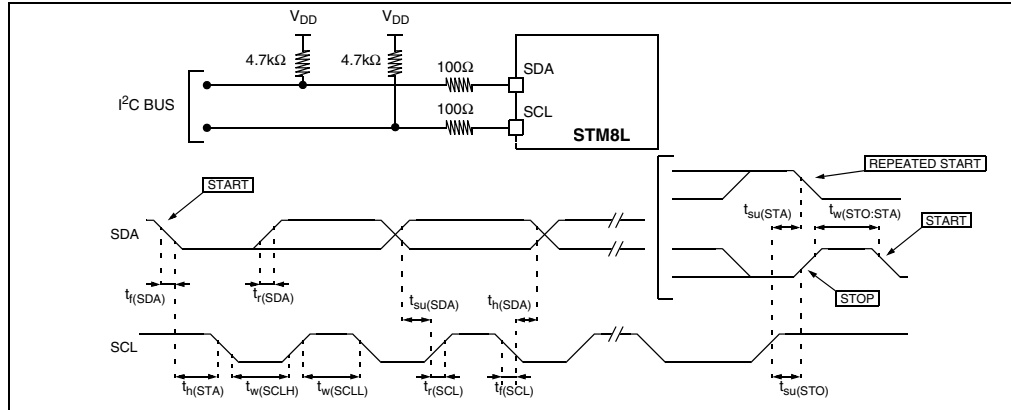

1. Measurement points are done at CMOS levels: 0.3 x V<sub>DD</sub> and 0.7 x V<sub>DD</sub>

### 7.3.9 Embedded reference voltage

In the following table, data are based on characterization results, not tested in production, unless otherwise specified.

**Table 41. Reference voltage characteristics**

Symbol	Parameter	Conditions	Min	Typ	Max.	Unit
$I_{REFINT}$	Internal reference voltage consumption			1.4		$\mu\text{A}$
$T_{S\_VREFINT}^{(1)(2)}$	ADC1 sampling time when reading the internal reference voltage			5	10	$\mu\text{s}$
$I_{BUF}^{(2)}$	Internal reference voltage buffer consumption (used for ADC1)			13.5	25	$\mu\text{A}$
$V_{REFINT\ out}$	Reference voltage output		1.202 <sup>(3)</sup>	1.224	1.242 <sup>(3)</sup>	V
$I_{LPBUF}^{(2)}$	Internal reference voltage low power buffer consumption (used for comparators or output)			730	1200	nA
$I_{REFOUT}^{(2)}$	Buffer output current <sup>(4)</sup>				1	$\mu\text{A}$
$C_{REFOUT}$	Reference voltage output load				50	pF
$t_{VREFINT}$	Internal reference voltage startup time			2	3	ms
$t_{BUFEN}^{(2)}$	Internal reference voltage buffer startup time once enabled <sup>(1)</sup>				10	$\mu\text{s}$
$ACC_{VREFINT}$	Accuracy of $V_{REFINT}$ stored in the $VREFINT\_Factory\_CONV$ byte <sup>(5)</sup>				$\pm 5$	mV
$STAB_{VREFINT}$	Stability of $V_{REFINT}$ over temperature	$-40\text{ }^{\circ}\text{C} \leq T_A \leq 125\text{ }^{\circ}\text{C}$		20	50	ppm/ $^{\circ}\text{C}$
	Stability of $V_{REFINT}$ over temperature	$0\text{ }^{\circ}\text{C} \leq T_A \leq 50\text{ }^{\circ}\text{C}$			20	ppm/ $^{\circ}\text{C}$
$STAB_{VREFINT}$	Stability of $V_{REFINT}$ after 1000 hours				TBD	ppm

1. Defined when ADC1 output reaches its final value  $\pm 1/2\text{LSB}$
2. Data guaranteed by Design. Not tested in production.
3. Tested in production at  $V_{DD} = 3\text{ V} \pm 10\text{ mV}$ .
4. To guaranty less than 1%  $V_{REFOUT}$  deviation
5. Measured at  $V_{DD} = 3\text{ V} \pm 10\text{ mV}$ . This value takes into account  $V_{DD}$  accuracy and ADC1 conversion accuracy.

### 7.3.10 Temperature sensor

In the following table, data are based on characterization results, not tested in production, unless otherwise specified.

**Table 42. TS characteristics**

Symbol	Parameter	Min	Typ	Max.	Unit
$V_{90}^{(1)}$	Sensor reference voltage at $90^{\circ}\text{C} \pm 5^{\circ}\text{C}$ ,	0.580	0.597	0.614	V
$T_L$	$V_{\text{SENSOR}}$ linearity with temperature		$\pm 1$	$\pm 2$	$^{\circ}\text{C}$
Avg_slope <sup>(2)</sup>	Average slope	1.59	1.62	1.65	mV/ $^{\circ}\text{C}$
$I_{\text{DD(TEMP)}}^{(2)}$	Consumption		3.4	6	$\mu\text{A}$
$T_{\text{START}}^{(2)(3)}$	Temperature sensor startup time			10	$\mu\text{s}$
$T_{\text{S\_TEMP}}^{(2)}$	ADC1 sampling time when reading the temperature sensor	10			$\mu\text{s}$

1. Tested in production at  $V_{\text{DD}} = 3\text{ V} \pm 10\text{ mV}$ . The 8 LSB of the  $V_{90}$  ADC1 conversion result are stored in the TS\_Factory\_CONV\_V90 byte.

2. Data guaranteed by design, not tested in production.

3. Defined for ADC1 output reaching its final value  $\pm 1/2\text{LSB}$ .

### 7.3.11 Comparator characteristics

In the following table, data are guaranteed by design, not tested in production, unless otherwise specified.

**Table 43. Comparator 1 characteristics**

Symbol	Parameter	Min	Typ	Max <sup>(1)</sup>	Unit
$V_{\text{DDA}}$	Analog supply voltage	1.65		3.6	V
$T_A$	Temperature range	-40		125	$^{\circ}\text{C}$
$R_{400\text{K}}$	$R_{400\text{K}}$ value	300	400	500	$\text{k}\Omega$
$R_{10\text{K}}$	$R_{10\text{K}}$ value	7.5	10	12.5	
$V_{\text{IN}}$	Comparator 1 input voltage range	0.6		$V_{\text{DDA}}$	V
$V_{\text{REFINT}}$	Internal reference voltage <sup>(2)</sup>	1.202	1.224	1.242	
$t_{\text{START}}$	Comparator startup time		7	10	$\mu\text{s}$
$t_d$	Propagation delay <sup>(3)</sup>		3	10	
$V_{\text{offset}}$	Comparator offset error		$\pm 3$	$\pm 10$	mV
$I_{\text{COMP1}}$	Current consumption <sup>(4)</sup>		160	260	nA

1. Based on characterization, not tested in production.

2. Tested in production at  $V_{\text{DD}} = 3\text{ V} \pm 10\text{ mV}$ .

3. The delay is characterized for 100 mV input step with 10 mV overdrive on the inverting input, the non-inverting input set to the reference.

4. Comparator consumption only. Internal reference voltage not included.

In the following table, data are guaranteed by design, not tested in production.

**Table 44. Comparator 2 characteristics**

Symbol	Parameter	Conditions	Min	Typ	Max <sup>(1)</sup>	Unit
V <sub>DDA</sub>	Analog supply voltage		1.65		3.6	V
T <sub>A</sub>	Temperature range		-40		125	°C
V <sub>IN</sub>	Comparator 2 input voltage range		0		V <sub>DDA</sub>	V
t <sub>START</sub>	Comparator startup time	Fast mode		15	20	μs
		Slow mode		20	25	
t <sub>d slow</sub>	Propagation delay in slow mode <sup>(2)</sup>	1.65 V ≤ V <sub>DDA</sub> ≤ 2.7 V		1.8	3.5	
		2.7 V ≤ V <sub>DDA</sub> ≤ 3.6 V		2.5	6	
t <sub>d fast</sub>	Propagation delay in fast mode <sup>(2)</sup>	1.65 V ≤ V <sub>DDA</sub> ≤ 2.7 V		0.8	2	
		2.7 V ≤ V <sub>DDA</sub> ≤ 3.6 V		1.2	4	
V <sub>offset</sub>	Comparator offset error			±4	±20	
I <sub>COMP2</sub>	Current consumption <sup>(3)</sup>	Fast mode		3.5	5	μA
		Slow mode		0.5	2	

1. Based on characterization, not tested in production.
2. The delay is characterized for 100 mV input step with 10 mV overdrive on the inverting input, the non-inverting input set to the reference.
3. Comparator consumption only. Internal reference voltage not included.

### 7.3.12 12-bit ADC1 characteristics

In the following table, data are guaranteed by design, not tested in production.

**Table 45. ADC1 characteristics**

Symbol	Parameter	Conditions	Min	Typ	Max	Unit
$V_{DDA}$	Analog supply voltage		1.8		3.6	V
$V_{REF+}$	Reference supply voltage	$2.4\text{ V} \leq V_{DDA} \leq 3.6\text{ V}$	2.4		$V_{DDA}$	V
		$1.8\text{ V} \leq V_{DDA} \leq 2.4\text{ V}$		$V_{DDA}$		V
$V_{REF-}$	Lower reference voltage			$V_{SSA}$		V
$I_{VDDA}$	Current on the $V_{DDA}$ input pin			1000	1450	$\mu\text{A}$
$I_{VREF+}$	Current on the $V_{REF+}$ input pin			400	700 (peak) <sup>(1)</sup>	$\mu\text{A}$
					450 (average) <sup>(1)</sup>	$\mu\text{A}$
$V_{AIN}$	Conversion voltage range		0 <sup>(2)</sup>		$V_{REF+}$	
$T_A$	Temperature range		-40		125	$^{\circ}\text{C}$
$R_{AIN}$	External resistance on $V_{AIN}$	on PF0 fast channel			50 <sup>(3)</sup>	$\text{k}\Omega$
		on all other channels				
$C_{ADC1}$	Internal sample and hold capacitor	on PF0 fast channel		16		$\text{pF}$
		on all other channels				
$f_{ADC1}$	ADC1 sampling clock frequency	$2.4\text{ V} \leq V_{DDA} \leq 3.6\text{ V}$ without zooming	0.320		16	MHz
		$1.8\text{ V} \leq V_{DDA} \leq 2.4\text{ V}$ with zooming	0.320		8	MHz
$f_{CONV}$	12-bit conversion rate	$V_{AIN}$ on PF0 fast channel			1 <sup>(4)(5)</sup>	MHz
		$V_{AIN}$ on all other channels			760 <sup>(4)(5)</sup>	kHz
$f_{TRIG}$	External trigger frequency				$t_{conv}$	$1/f_{ADC1}$
$t_{LAT}$	External trigger latency				3.5	$1/f_{SYSCLK}$



Table 45. ADC1 characteristics (continued)

Symbol	Parameter	Conditions	Min	Typ	Max	Unit
$t_S$	Sampling time	$V_{AIN}$ on PF0 fast channel $V_{DDA} < 2.4$ V	0.43 <sup>(4)(5)</sup>			$\mu$ s
		$V_{AIN}$ on PF0 fast channel $2.4$ V $\leq V_{DDA} \leq 3.6$ V	0.22 <sup>(4)(5)</sup>			$\mu$ s
		$V_{AIN}$ on slow channels $V_{DDA} < 2.4$ V	0.86 <sup>(4)(5)</sup>			$\mu$ s
		$V_{AIN}$ on slow channels $2.4$ V $\leq V_{DDA} \leq 3.6$ V	0.41 <sup>(4)(5)</sup>			$\mu$ s
$t_{conv}$	12-bit conversion time		12 + $t_S$			1/ $f_{ADC1}$
		16 MHz	1 <sup>(4)</sup>			$\mu$ s
$t_{WKUP}$	Wakeup time from OFF state				3	$\mu$ s
$t_{IDLE}^{(6)}$	Time before a new conversion	$T_A = +25$ °C			1 <sup>(7)</sup>	s
		$T_A = +70$ °C			20 <sup>(7)</sup>	ms
		$T_A = +125$ °C			2 <sup>(7)</sup>	ms
$t_{VREFINT}$	Internal reference voltage startup time				refer to <a href="#">Table 41</a>	ms

- The current consumption through  $V_{REF}$  is composed of two parameters:
  - one constant (max 300  $\mu$ A)
  - one variable (max 400  $\mu$ A), only during sampling time + 2 first conversion pulses.
 So, peak consumption is 300+400 = 700  $\mu$ A and average consumption is  $300 + [(4 \text{ sampling} + 2) / 16] \times 400 = 450$   $\mu$ A at 1Msps
- $V_{REF}$  or  $V_{DDA}$  must be tied to ground.
- Guaranteed by design, not tested in production.
- Minimum sampling and conversion time is reached for maximum  $R_{ext} = 0.5$  k $\Omega$
- Value obtained for continuous conversion on fast channel.
- The time between 2 conversions, or between ADC1 ON and the first conversion must be lower than  $t_{IDLE}$ .
- The  $t_{IDLE}$  maximum value is  $\infty$  on the "Z" revision code of the device.

In the following three tables, data are guaranteed by characterization result, not tested in production.

**Table 46. ADC1 accuracy with  $V_{DDA} = 3.3\text{ V to }2.5\text{ V}$**

Symbol	Parameter	Conditions	Typ	Max	Unit
DNL	Differential non linearity	$f_{\text{ADC1}} = 16\text{ MHz}$	1	1.6	LSB
		$f_{\text{ADC1}} = 8\text{ MHz}$	1	1.6	
		$f_{\text{ADC1}} = 4\text{ MHz}$	1	1.5	
INL	Integral non linearity	$f_{\text{ADC1}} = 16\text{ MHz}$	1.2	2	
		$f_{\text{ADC1}} = 8\text{ MHz}$	1.2	1.8	
		$f_{\text{ADC1}} = 4\text{ MHz}$	1.2	1.7	
TUE	Total unadjusted error	$f_{\text{ADC1}} = 16\text{ MHz}$	2.2	3.0	
		$f_{\text{ADC1}} = 8\text{ MHz}$	1.8	2.5	
		$f_{\text{ADC1}} = 4\text{ MHz}$	1.8	2.3	
Offset	Offset error	$f_{\text{ADC1}} = 16\text{ MHz}$	1.5	2	LSB
		$f_{\text{ADC1}} = 8\text{ MHz}$	1	1.5	
		$f_{\text{ADC1}} = 4\text{ MHz}$	0.7	1.2	
Gain	Gain error	$f_{\text{ADC1}} = 16\text{ MHz}$	1	1.5	
		$f_{\text{ADC1}} = 8\text{ MHz}$			
		$f_{\text{ADC1}} = 4\text{ MHz}$			

**Table 47. ADC1 accuracy with  $V_{DDA} = 2.4\text{ V to }3.6\text{ V}$**

Symbol	Parameter	Typ	Max	Unit
DNL	Differential non linearity	1	2	LSB
INL	Integral non linearity	1.7	3	LSB
TUE	Total unadjusted error	2	4	LSB
Offset	Offset error	1	2	LSB
Gain	Gain error	1.5	3	LSB

**Table 48. ADC1 accuracy with  $V_{DDA} = V_{\text{REF}}^+ = 1.8\text{ V to }2.4\text{ V}$**

Symbol	Parameter	Typ	Max	Unit
DNL	Differential non linearity	1	2	LSB
INL	Integral non linearity	2	3	LSB
TUE	Total unadjusted error	3	5	LSB
Offset	Offset error	2	3	LSB
Gain	Gain error	2	3	LSB

**Figure 37. ADC1 accuracy characteristics**

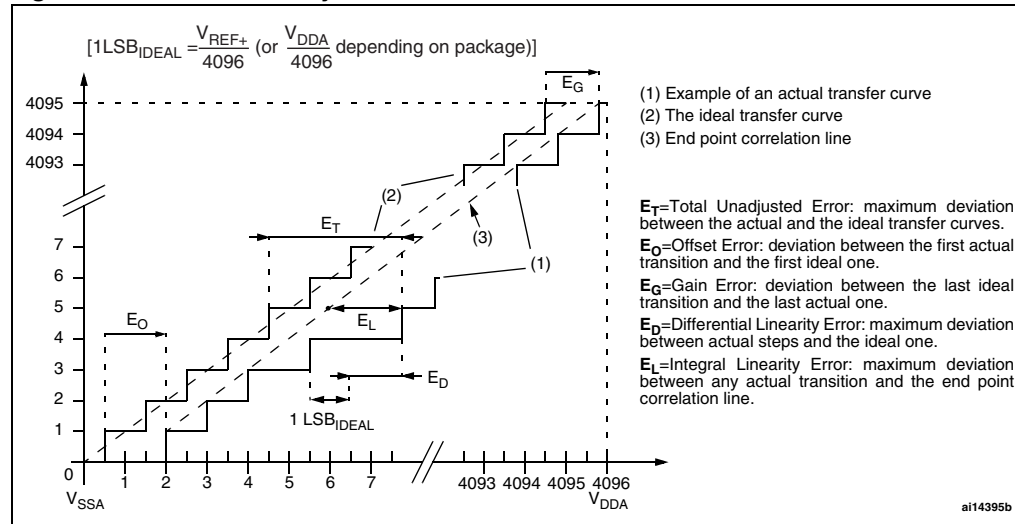

**Figure 38. Typical connection diagram using the ADC1**

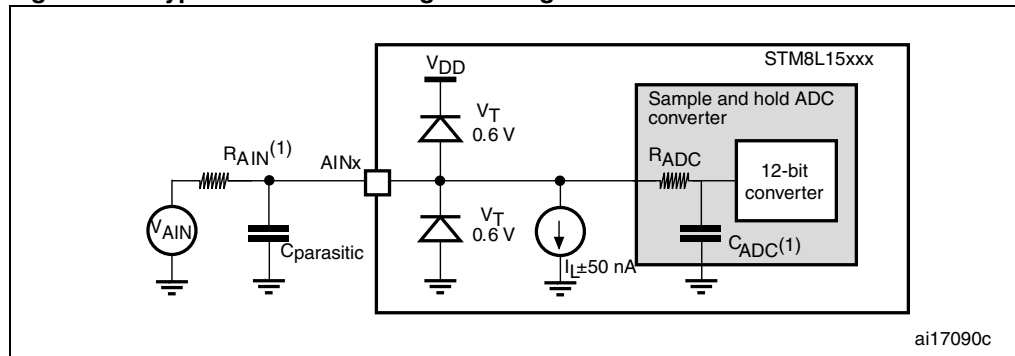

1. Refer to [Table 45](#) for the values of  $R_{AIN}$  and  $C_{ADC1}$ .
2.  $C_{parasitic}$  represents the capacitance of the PCB (dependent on soldering and PCB layout quality) plus the pad capacitance (roughly 7 pF). A high  $C_{parasitic}$  value will downgrade conversion accuracy. To remedy this,  $f_{ADC1}$  should be reduced.

**General PCB design guidelines**

Power supply decoupling should be performed as shown in [Figure 39](#) or [Figure 40](#), depending on whether  $V_{REF+}$  is connected to  $V_{DDA}$  or not. Good quality ceramic 10 nF capacitors should be used. They should be placed as close as possible to the chip.

Figure 39. Power supply and reference decoupling ( $V_{REF+}$  not connected to  $V_{DDA}$ )

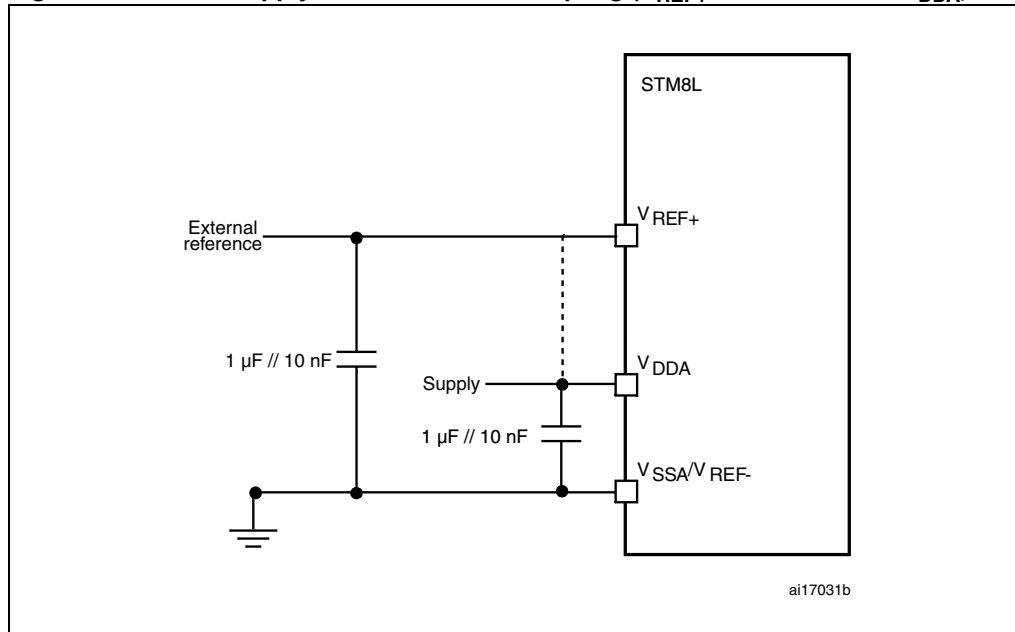
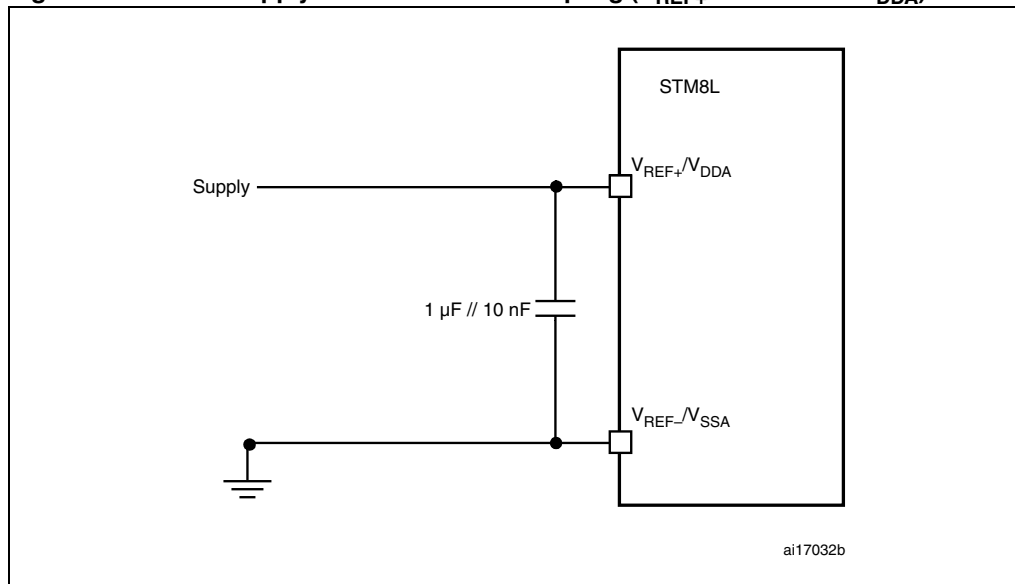
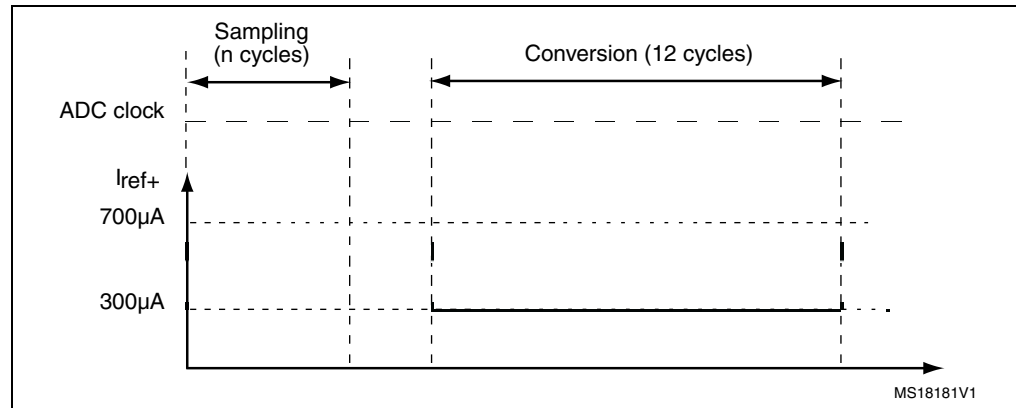

Figure 40. Power supply and reference decoupling ( $V_{REF+}$  connected to  $V_{DDA}$ )



**Figure 41. Max. dynamic current consumption on  $V_{REF+}$  supply pin during ADC conversion**



**Table 49.  $R_{AIN}$  max for  $f_{ADC} = 16$  MHz**

$t_s$ (cycles)	$t_s$ ( $\mu s$ )	$R_{AIN}$ max (kohm)			
		Slow channels		Fast channels	
		$2.4 V < V_{DDA} < 3.6 V$	$1.8 V < V_{DDA} < 2.4 V$	$2.4 V < V_{DDA} < 3.3 V$	$1.8 V < V_{DDA} < 2.4 V$
4	0.25	Not allowed	Not allowed	0.7	Not allowed
9	0.5625	0.8	Not allowed	2.0	1.0
16	1	2.0	0.8	4.0	3.0
24	1.5	3.0	1.8	6.0	4.5
48	3	6.8	4.0	15.0	10.0
96	6	15.0	10.0	30.0	20.0
192	12	32.0	25.0	50.0	40.0
384	24	50.0	50.0	50.0	50.0

### 7.3.13 EMC characteristics

Susceptibility tests are performed on a sample basis during product characterization.

#### Functional EMS (electromagnetic susceptibility)

Based on a simple running application on the product (toggling 2 LEDs through I/O ports), the product is stressed by two electromagnetic events until a failure occurs (indicated by the LEDs).

- **ESD:** Electrostatic discharge (positive and negative) is applied on all pins of the device until a functional disturbance occurs. This test conforms with the IEC 61000 standard.
- **FTB:** A burst of fast transient voltage (positive and negative) is applied to  $V_{DD}$  and  $V_{SS}$  through a 100 pF capacitor, until a functional disturbance occurs. This test conforms with the IEC 61000 standard.

A device reset allows normal operations to be resumed. The test results are given in the table below based on the EMS levels and classes defined in application note AN1709.

### Designing hardened software to avoid noise problems

EMC characterization and optimization are performed at component level with a typical application environment and simplified MCU software. It should be noted that good EMC performance is highly dependent on the user application and the software in particular.

Therefore it is recommended that the user applies EMC software optimization and prequalification tests in relation with the EMC level requested for his application.

### Prequalification trials

Most of the common failures (unexpected reset and program counter corruption) can be reproduced by manually forcing a low state on the NRST pin or the Oscillator pins for 1 second.

To complete these trials, ESD stress can be applied directly on the device, over the range of specification values. When unexpected behavior is detected, the software can be hardened to prevent unrecoverable errors occurring (see application note AN1015).

**Table 50. EMS data**

Symbol	Parameter	Conditions	Level/Class	
$V_{FESD}$	Voltage limits to be applied on any I/O pin to induce a functional disturbance	$V_{DD} = 3.3\text{ V}$ , $T_A = +25\text{ °C}$ , $f_{CPU} = 16\text{ MHz}$ , conforms to IEC 61000	2B	
$V_{EFTB}$	Fast transient voltage burst limits to be applied through 100 pF on $V_{DD}$ and $V_{SS}$ pins to induce a functional disturbance	$V_{DD} = 3.3\text{ V}$ , $T_A = +25\text{ °C}$ , $f_{CPU} = 16\text{ MHz}$ , conforms to IEC 61000	Using HSI	4A
			Using HSE	2B

### Electromagnetic interference (EMI)

Based on a simple application running on the product (toggling 2 LEDs through the I/O ports), the product is monitored in terms of emission. This emission test is in line with the norm IEC61967-2 which specifies the board and the loading of each pin.

**Table 51. EMI data <sup>(1)</sup>**

Symbol	Parameter	Conditions	Monitored frequency band	Max vs.	Unit
				16 MHz	
$S_{EMI}$	Peak level	$V_{DD} = 3.6\text{ V}$ , $T_A = +25\text{ °C}$ , LQFP48 conforming to IEC61967-2	0.1 MHz to 30 MHz	-3	dB $\mu$ V
			30 MHz to 130 MHz	9	
			130 MHz to 1 GHz	4	
			SAE EMI Level	2	-

1. Not tested in production.

### Absolute maximum ratings (electrical sensitivity)

Based on two different tests (ESD and LU) using specific measurement methods, the product is stressed in order to determine its performance in terms of electrical sensitivity. For more details, refer to the application note AN1181.

### Electrostatic discharge (ESD)

Electrostatic discharges (a positive then a negative pulse separated by 1 second) are applied to the pins of each sample according to each pin combination. The sample size depends on the number of supply pins in the device (3 parts\*(n+1) supply pin). Two models can be simulated: human body model and charge device model. This test conforms to the JESD22-A114A/A115A standard.

**Table 52. ESD absolute maximum ratings**

Symbol	Ratings	Conditions	Maximum value <sup>(1)</sup>	Unit
$V_{ESD(HBM)}$	Electrostatic discharge voltage (human body model)	$T_A = +25\text{ }^\circ\text{C}$	2000	V
$V_{ESD(CDM)}$	Electrostatic discharge voltage (charge device model)		500	

1. Data based on characterization results, not tested in production.

### Static latch-up

- **LU:** 3 complementary static tests are required on 6 parts to assess the latch-up performance. A supply overvoltage (applied to each power supply pin) and a current injection (applied to each input, output and configurable I/O pin) are performed on each sample. This test conforms to the EIA/JESD 78 IC latch-up standard. For more details, refer to the application note AN1181.

**Table 53. Electrical sensitivities**

Symbol	Parameter	Class
LU	Static latch-up class	II

## 7.4 Thermal characteristics

The maximum chip junction temperature ( $T_{Jmax}$ ) must never exceed the values given in [Table 14: General operating conditions on page 52](#).

The maximum chip-junction temperature,  $T_{Jmax}$ , in degree Celsius, may be calculated using the following equation:

$$T_{Jmax} = T_{Amax} + (P_{Dmax} \times \Theta_{JA})$$

Where:

- $T_{Amax}$  is the maximum ambient temperature in °C
- $\Theta_{JA}$  is the package junction-to-ambient thermal resistance in °C/W
- $P_{Dmax}$  is the sum of  $P_{INTmax}$  and  $P_{I/Omax}$  ( $P_{Dmax} = P_{INTmax} + P_{I/Omax}$ )
- $P_{INTmax}$  is the product of  $I_{DD}$  and  $V_{DD}$ , expressed in Watts. This is the maximum chip internal power.
- $P_{I/Omax}$  represents the maximum power dissipation on output pins

Where:

$$P_{I/Omax} = \Sigma (V_{OL} * I_{OL}) + \Sigma ((V_{DD} - V_{OH}) * I_{OH}),$$

taking into account the actual  $V_{OL}/I_{OL}$  and  $V_{OH}/I_{OH}$  of the I/Os at low and high level in the application.

**Table 54. Thermal characteristics<sup>(1)</sup>**

Symbol	Parameter	Value	Unit
$\Theta_{JA}$	Thermal resistance junction-ambient LQFP 48- 7 x 7 mm	65	°C/W
$\Theta_{JA}$	Thermal resistance junction-ambient UFQFPN 32 - 5 x 5 mm	38	°C/W
$\Theta_{JA}$	Thermal resistance junction-ambient UFQFPN28 - 4 x 4 mm	80	°C/W
$\Theta_{JA}$	Thermal resistance junction-ambient UFQFPN20 - 3 x 3 mm	102	°C/W
$\Theta_{JA}$	Thermal resistance junction-ambient TSSOP20	110	°C/W

1. Thermal resistances are based on JEDEC JESD51-2 with 4-layer PCB in a natural convection environment.



## 8 Option bytes

Option bytes contain configurations for device hardware features as well as the memory protection of the device. They are stored in a dedicated memory block.

All option bytes can be modified in ICP mode (with SWIM) by accessing the EEPROM address. See [Table 55](#) for details on option byte addresses.

The option bytes can also be modified 'on the fly' by the application in IAP mode, except for the ROP and UBC values which can only be taken into account when they are modified in ICP mode (with the SWIM).

Refer to the STM8L15x Flash programming manual (PM0054) and STM8 SWIM and Debug Manual (UM0470) for information on SWIM programming procedures.

**Table 55. Option byte addresses**

Addr.	Option name	Option byte No.	Option bits								Factory default setting
			7	6	5	4	3	2	1	0	
0x00 4800	Read-out protection (ROP)	OPT0	ROP[7:0]								0xAA
0x00 4802	UBC (User Boot code size)	OPT1	UBC[7:0]								0x00
0x00 4807	Reserved								0x00		
0x00 4808	Independent watchdog option	OPT3 [3:0]	Reserved				WWDG _HALT	WWDG _HW	IWDG _HALT	IWDG _HW	0x00
0x00 4809	Number of stabilization clock cycles for HSE and LSE oscillators	OPT4	Reserved				LSECNT[1:0]		HSECNT[1:0]		0x00
0x00 480A	Brownout reset (BOR)	OPT5 [3:0]	Reserved				BOR_TH			BOR_ON	0x01
0x00 480B	Bootloader option bytes (OPTBL)	OPTBL [15:0]	OPTBL[15:0]								0x00
0x00 480C											0x00

Table 56. Option byte description

Option byte No.	Option description
OPT0	<b>ROP[7:0]</b> Memory readout protection (ROP) 0xAA: Disable readout protection (write access via SWIM protocol) Refer to Readout protection section in the STM8L15x and STM8L16x reference manual (RM0031).
OPT1	<b>UBC[7:0]</b> Size of the user boot code area 0x00: UBC is not protected. 0x01: Page 0 is write protected. 0x02: Page 0 and 1 reserved for the UBC and write protected. It covers only the interrupt vectors. 0x03: Page 0 to 2 reserved for UBC and write protected. 0x7F to 0xFF - All 128 pages reserved for UBC and write protected. The protection of the memory area not protected by the UBC is enabled through the MASS keys. Refer to User boot code section in the STM8L15x and STM8L16x reference manual (RM0031).
OPT2	Reserved
OPT3	<b>IWDG_HW</b> : Independent watchdog 0: Independent watchdog activated by software 1: Independent watchdog activated by hardware
	<b>IWDG_HALT</b> : Independent window watchdog off on Halt/Active-halt 0: Independent watchdog continues running in Halt/Active-halt mode 1: Independent watchdog stopped in Halt/Active-halt mode
	<b>WWDG_HW</b> : Window watchdog 0: Window watchdog activated by software 1: Window watchdog activated by hardware
	<b>WWDG_HALT</b> : Window window watchdog reset on Halt/Active-halt 0: Window watchdog stopped in Halt mode 1: Window watchdog generates a reset when MCU enters Halt mode
OPT4	<b>HSECNT</b> : Number of HSE oscillator stabilization clock cycles 0x00 - 1 clock cycle 0x01 - 16 clock cycles 0x10 - 512 clock cycles 0x11 - 4096 clock cycles
	<b>LSECNT</b> : Number of LSE oscillator stabilization clock cycles 0x00 - 1 clock cycle 0x01 - 16 clock cycles 0x10 - 512 clock cycles 0x11 - 4096 clock cycles Refer to <a href="#">Table 28: LSE oscillator characteristics on page 67</a> .

Table 56. Option byte description (continued)

Option byte No.	Option description
OPT5	<p><b>BOR_ON:</b>            0: Brownout reset off            1: Brownout reset on</p> <p><b>BOR_TH[3:1]:</b> Brownout reset thresholds. Refer to <a href="#">Table 19</a> for details on the thresholds according to the value of BOR_TH bits.</p>
OPTBL	<p><b>OPTBL[15:0]:</b>            This option is checked by the boot ROM code after reset. Depending on content of addresses 00 480B, 00 480C and 0x8000 (reset vector) the CPU jumps to the bootloader or to the reset vector.            Refer to the UM0560 bootloader user manual for more details.</p>

## 9 Unique ID

STM8 devices feature a 96-bit unique device identifier which provides a reference number that is unique for any device and in any context. The 96 bits of the identifier can never be altered by the user.

The unique device identifier can be read in single bytes and may then be concatenated using a custom algorithm.

The unique device identifier is ideally suited:

- For use as serial numbers
- For use as security keys to increase the code security in the program memory while using and combining this unique ID with software cryptographic primitives and protocols before programming the internal memory.
- To activate secure boot processes

**Table 57. Unique ID registers (96 bits)**

Address	Content description	Unique ID bits							
		7	6	5	4	3	2	1	0
0x4926	X co-ordinate on the wafer	U_ID[7:0]							
0x4927		U_ID[15:8]							
0x4928	Y co-ordinate on the wafer	U_ID[23:16]							
0x4929		U_ID[31:24]							
0x492A	Wafer number	U_ID[39:32]							
0x492B	Lot number	U_ID[47:40]							
0x492C		U_ID[55:48]							
0x492D		U_ID[63:56]							
0x492E		U_ID[71:64]							
0x492F		U_ID[79:72]							
0x4930		U_ID[87:80]							
0x4931		U_ID[95:88]							

## 10 Package characteristics

### 10.1 ECOPACK

In order to meet environmental requirements, ST offers these devices in different grades of ECOPACK® packages, depending on their level of environmental compliance. ECOPACK® specifications, grade definitions and product status are available at: [www.st.com](http://www.st.com). ECOPACK® is an ST trademark.

## 10.2 Package mechanical data

Figure 42. LQFP48 – 48-pin low profile quad flat package outline (7x7)

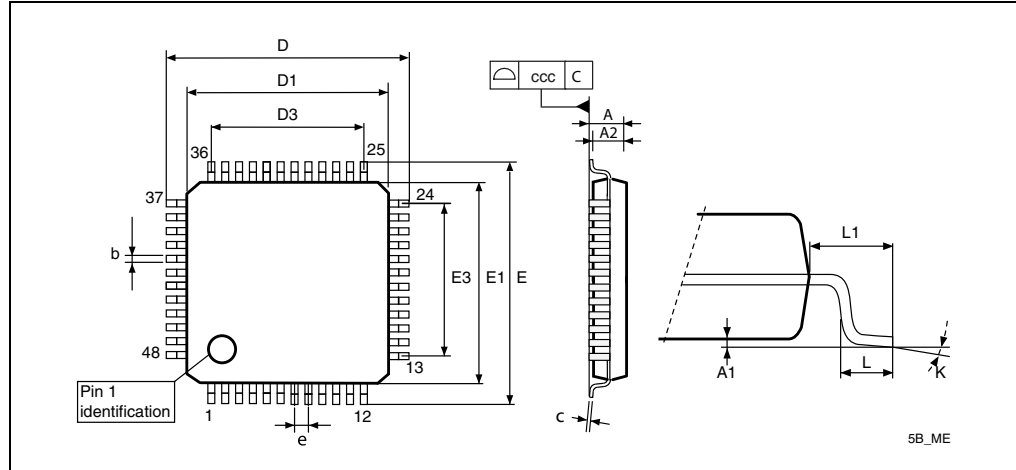

Table 58. LQFP48 – 48-pin low profile quad flat package (7x7), package mechanical data

Dim.	mm			inches <sup>(1)</sup>		
	Min	Typ	Max	Min	Typ	Max
A			1.6			0.063
A1	0.05		0.15	0.002		0.0059
A2	1.35	1.4	1.45	0.0531	0.0551	0.0571
b	0.17	0.22	0.27	0.0067	0.0087	0.0106
c	0.09		0.2	0.0035		0.0079
D	8.8	9	9.2	0.3465	0.3543	0.3622
D1	6.8	7	7.2	0.2677	0.2756	0.2835
D3		5.5			0.2165	
E	8.8	9	9.2	0.3465	0.3543	0.3622
E1	6.8	7	7.2	0.2677	0.2756	0.2835
E3		5.5			0.2165	
e		0.5			0.0197	
L	0.45	0.6	0.75	0.0177	0.0236	0.0295
L1		1			0.0394	
k	0.0°	3.5°	7.0°	0.0°	3.5°	7.0°
ccc			0.08			0.0031
Number of pins						
N	48					

1. Values in inches are converted from mm and rounded to 4 decimal digits.

**Figure 43. UFQFPN32 - 32-lead ultra thin fine pitch quad flat no-lead package outline (5 x 5)<sup>(1)(2)(3)</sup>**

**Figure 44. UFQFPN32 recommended footprint<sup>(1)(4)</sup>**

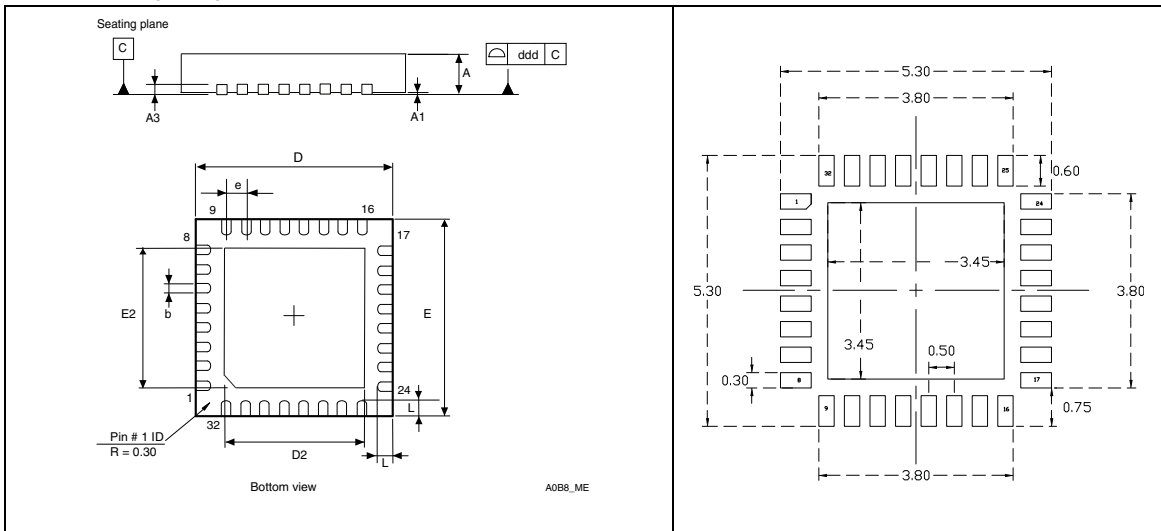

1. Drawing is not to scale.
2. All leads/pads should also be soldered to the PCB to improve the lead/pad solder joint life.
3. There is an exposed die pad on the underside of the UFQFPN package. It is recommended to connect and solder this back-side pad to PCB ground.
4. Dimensions are in millimeters.

**Table 59. UFQFPN32 - 32-lead ultra thin fine pitch quad flat no-lead package (5 x 5), package mechanical data**

Dim.	mm			inches <sup>(1)</sup>		
	Min	Typ	Max	Min	Typ	Max
A	0.5	0.55	0.6	0.0197	0.0217	0.0236
A1	0.00	0.02	0.05	0	0.0008	0.0020
A3		0.152			0.006	
b	0.18	0.23	0.28	0.0071	0.0091	0.0110
D	4.90	5.00	5.10	0.1929	0.1969	0.2008
D2		3.50			0.1378	
E	4.90	5.00	5.10	0.1929	0.1969	0.2008
E2	3.40	3.50	3.60	0.1339	0.1378	0.1417
e		0.500			0.0197	
L	0.30	0.40	0.50	0.0118	0.0157	0.0197
ddd		0.08			0.0031	
	Number of pins					
N	32					

1. Values in inches are converted from mm and rounded to 4 decimal digits.

Figure 45. UFQFPN28 – 28-lead ultra thin fine pitch quad flat no-lead package outline (4 x 4)

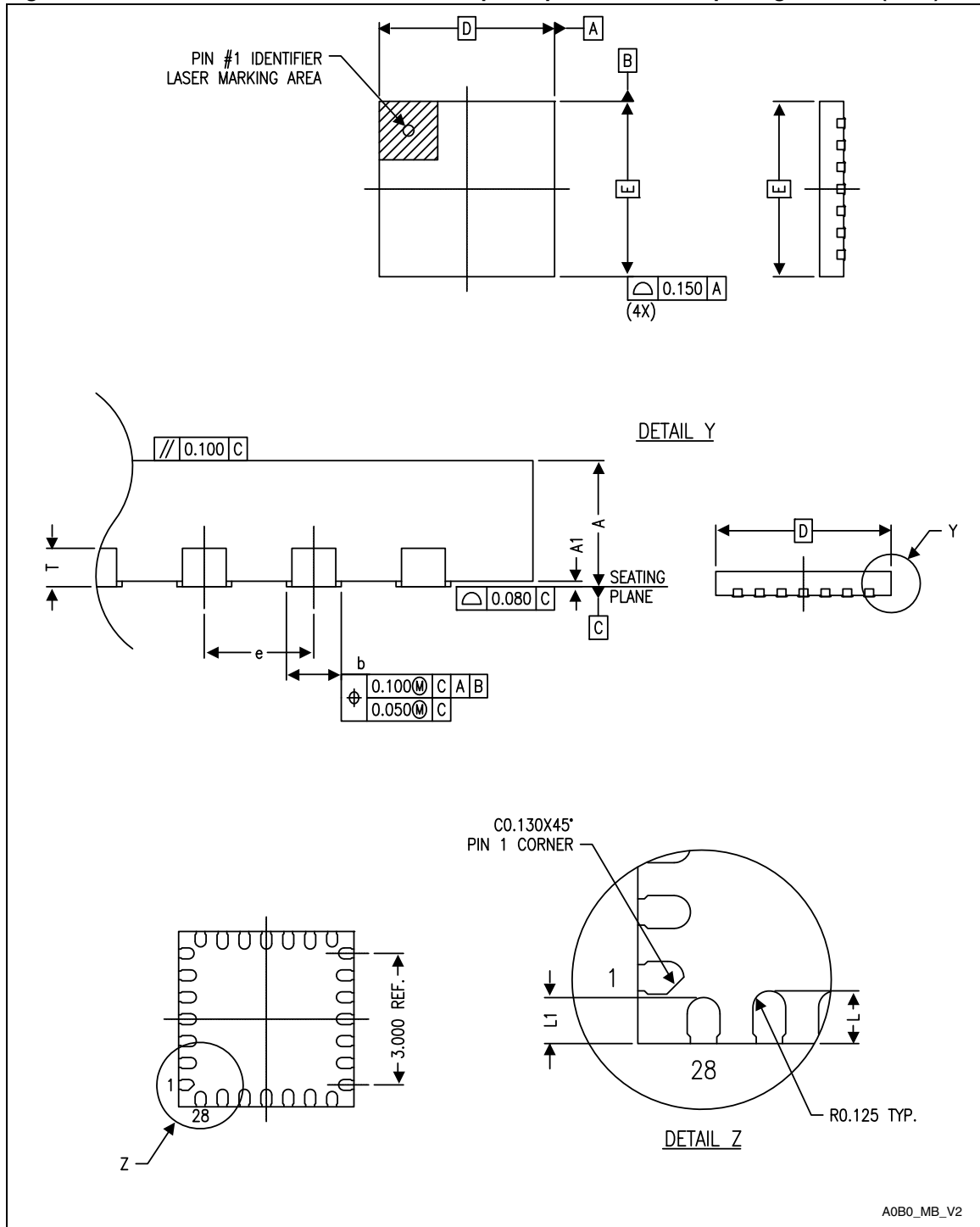

A0B0\_MB\_V2

1. Drawing is not to scale.



Figure 46. UFQFPN28 recommended footprint (dimensions in mm)

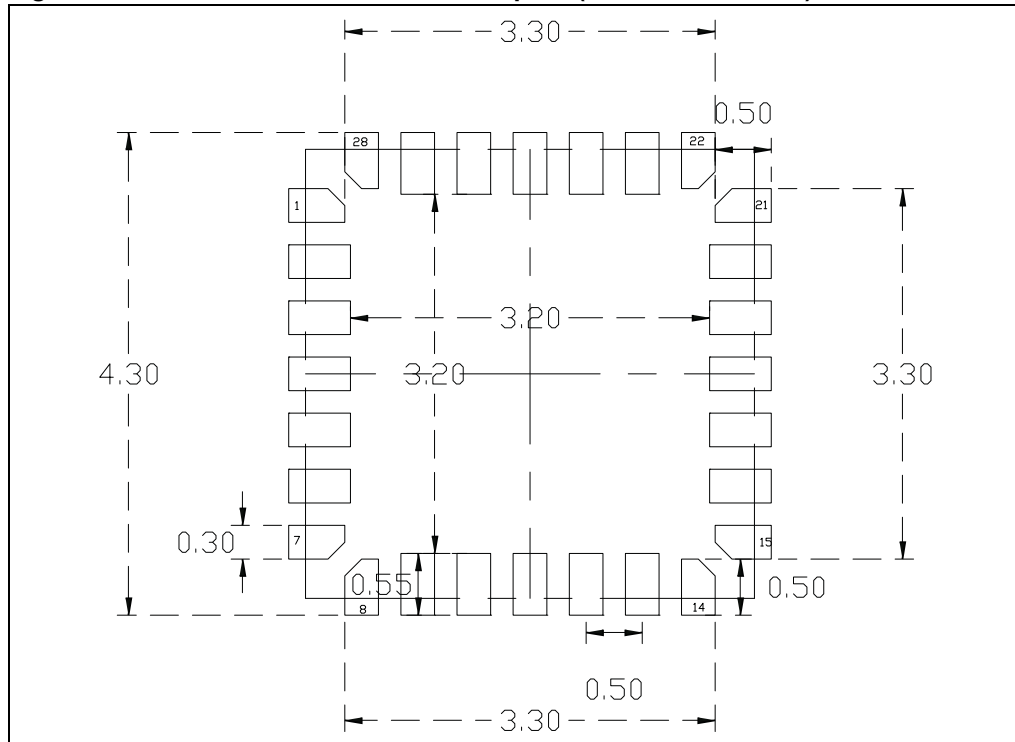

1. Drawing is not to scale.

Table 60. UFQFPN28 – 28-lead ultra thin fine pitch quad flat no-lead package (4 x 4), package mechanical data

Dim.	mm			inches <sup>(1)</sup>		
	Min	Typ	Max	Min	Typ	Max
A	0.500	0.550	0.600	0.0197	0.0217	0.0236
A1	0	0	0.050	0	0	0.002
D	3.900	4.000	4.100	0.1535	0.1575	0.1614
E	3.900	4.000	4.100	0.1535	0.1575	0.1614
L	0.300	0.400	0.500	0.0118	0.0157	0.0197
L1	0.250	0.350	0.450	0.0098	0.0138	0.0177
T		0.152			0.0060	
b	0.200	0.250	0.300	0.0079	0.0098	0.0118
e		0.500			0.0197	

1. Values in inches are converted from mm and rounded to 4 decimal digits.

**Figure 47. UFQFPN20 - 20-lead ultra thin fine pitch quad flat package outline (3x3)**

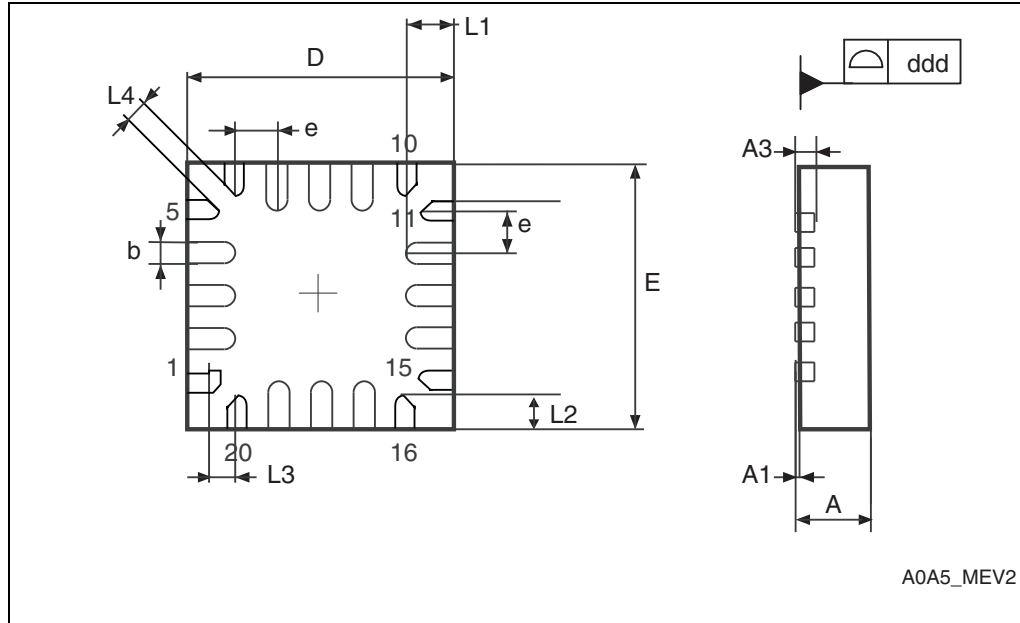

**Figure 48. UFQFPN20 recommended footprint (dimensions in mm)**

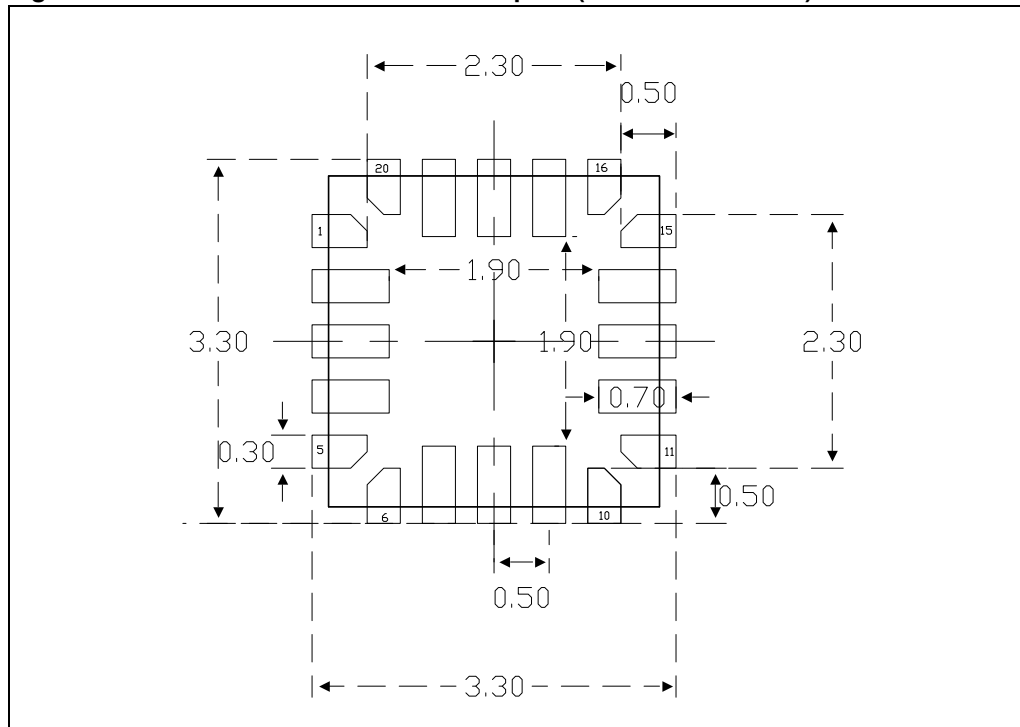

**Table 61. UFQFPN20 - 20-lead ultra thin fine pitch quad flat package (3x3)  
package mechanical data**

Dim.	mm			inches <sup>(1)</sup>		
	Min	Typ	Max	Min	Typ	Max
D		3.000			0.1181	
E		3.000			0.1181	
A	0.500	0.550	0.600	0.0197	0.0217	0.0236
A1	0.000	0.020	0.050	0.0000	0.0008	0.0020
A3		0.152			0.0060	
$\theta$	0 °		12 °	0 °		12 °
e		0.500			0.0197	
L1	0.500	0.550	0.600	0.0197	0.0217	0.0236
L2	0.300	0.350	0.400	0.0118	0.0138	0.0157
L3		0.150			0.0059	
L4		0.200			0.0079	
b	0.180	0.250	0.300	0.0071	0.0098	0.0118
	Tolerance (mm)			Tolerance (inches)		
ddd		0.050			0.0020	

1. Values in inches are converted from mm and rounded to 4 decimal digits.

Figure 49. TSSOP20 - 20-pin thin shrink small outline package

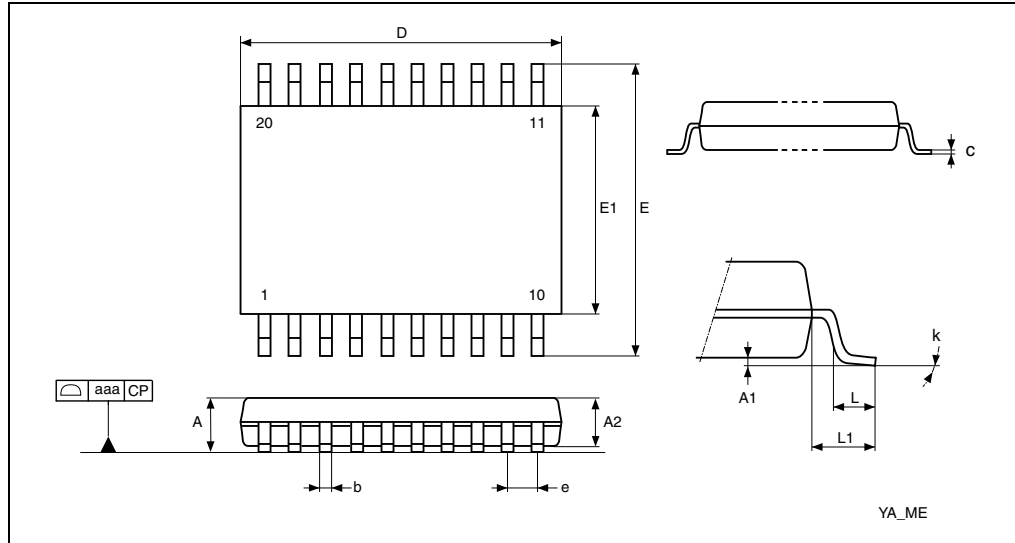

Table 62. TSSOP20 - 20-pin thin shrink small outline package mechanical data

Dim.	mm			inches <sup>(1)</sup>		
	Min	Typ	Max	Min	Typ	Max
A	—	—	1.200	—	—	0.0472
A1	0.050	—	0.150	0.0020	—	0.0059
A2	0.800	1.000	1.050	0.0315	0.0394	0.0413
b	0.190	—	0.300	0.0075	—	0.0118
c	0.090	—	0.200	0.0035	—	0.0079
D	6.400	6.500	6.600	0.2520	0.2559	0.2598
E	6.200	6.400	6.600	0.2441	0.2520	0.2598
E1	4.300	4.400	4.500	0.1693	0.1732	0.1772
e	—	0.650	—	—	0.0256	—
L	0.450	0.600	0.750	0.0177	0.0236	0.0295
L1	—	1.000	—	—	0.0394	—

1. Values in inches are converted from mm and rounded to 4 decimal digits

# 11 Device ordering information

Figure 50. Low density STM8L15xxx ordering information scheme

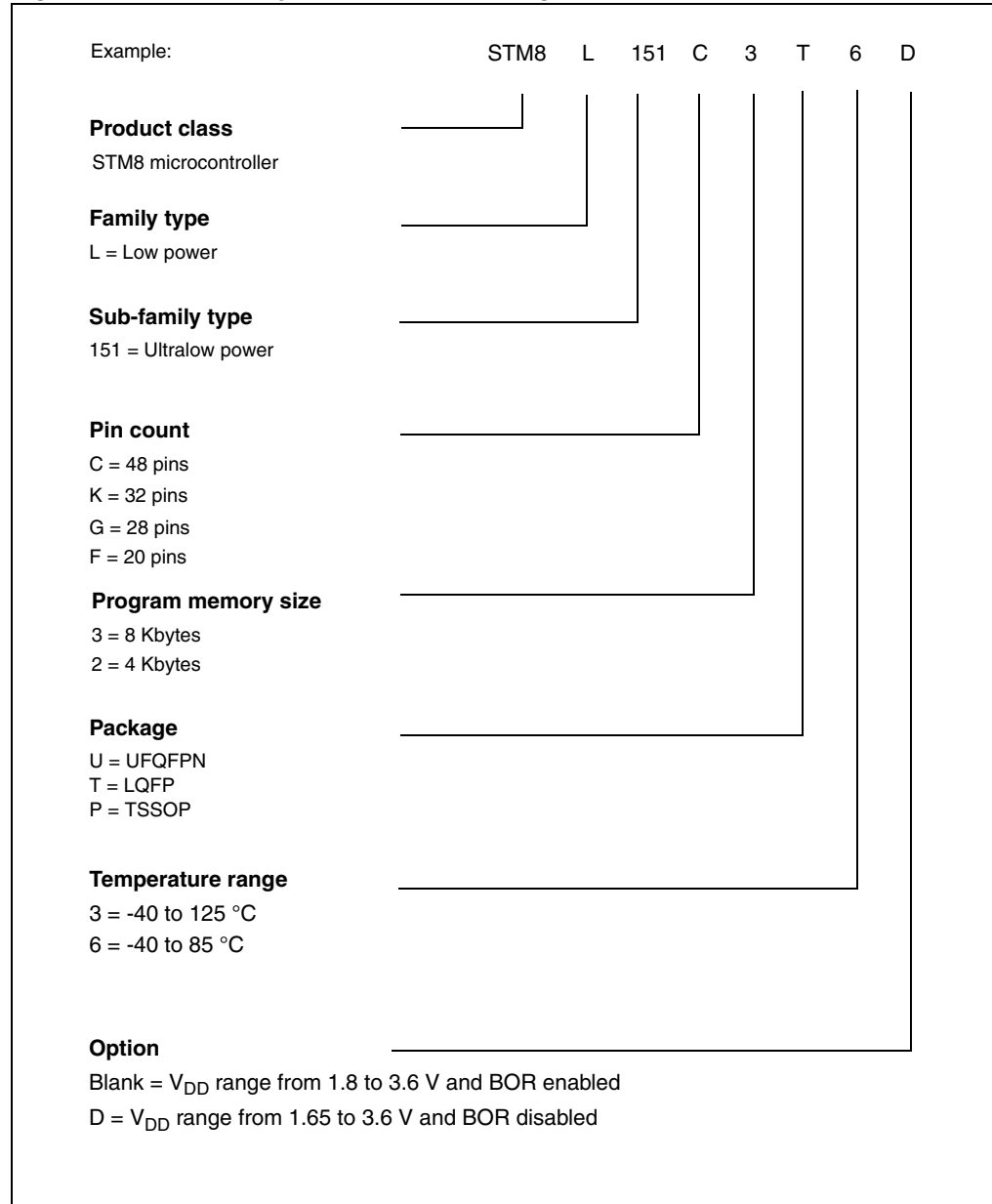

1. For a list of available options (e.g. memory size, package) and orderable part numbers or for further information on any aspect of this device, please contact the ST sales office nearest to you

## 12 Revision history

Table 63. Document revision history

Date	Revision	Changes
08-Jun-2011	1	Initial release
02-Sep-2011	2	<p>Modified <a href="#">Figure 8: Memory map on page 33</a>.</p> <p>Modified OPT1 description in <a href="#">Table 12: Option byte addresses on page 52</a></p> <p>Modified <math>t_{prog}</math> in <a href="#">Table 36: Flash program and data EEPROM memory on page 79</a></p> <p>Modified <a href="#">Figure 32: Recommended NRST pin configuration on page 88</a></p> <p>Modified L2 in <a href="#">Figure 47: UFQFPN20 - 20-lead ultra thin fine pitch quad flat package outline (3x3) on page 110</a></p> <p>PM0051 replaced with PM0054 and UM0320 replaced with UM0470.</p>
09-Feb-2012	3	<p>Added part number STM8L151C2.</p> <p><a href="#">Figure 3</a> and <a href="#">Figure 4</a>: updated titles.</p> <p><a href="#">Table 4: Low density STM8L15xxx pin description</a>: updated OD column of NRST/PA1 pin.</p> <p><a href="#">Figure 43: UFQFPN32 - 32-lead ultra thin fine pitch quad flat no-lead package outline (5 x 5)</a>: removed the line over A1.</p> <p><a href="#">Figure 45: UFQFPN28 – 28-lead ultra thin fine pitch quad flat no-lead package outline (4 x 4)</a>: replaced to improve readability of UFQFPN28 package dimensions A, L, and L1.</p> <p><a href="#">Figure 46: UFQFPN28 recommended footprint (dimensions in mm)</a>: updated title.</p> <p><a href="#">Figure 48: UFQFPN20 recommended footprint (dimensions in mm)</a>: added.</p> <p><a href="#">Table 62: TSSOP20 - 20-pin thin shrink small outline package mechanical data</a>: updated title.</p>

**Please Read Carefully:**

Information in this document is provided solely in connection with ST products. STMicroelectronics NV and its subsidiaries ("ST") reserve the right to make changes, corrections, modifications or improvements, to this document, and the products and services described herein at any time, without notice.

All ST products are sold pursuant to ST's terms and conditions of sale.

Purchasers are solely responsible for the choice, selection and use of the ST products and services described herein, and ST assumes no liability whatsoever relating to the choice, selection or use of the ST products and services described herein.

No license, express or implied, by estoppel or otherwise, to any intellectual property rights is granted under this document. If any part of this document refers to any third party products or services it shall not be deemed a license grant by ST for the use of such third party products or services, or any intellectual property contained therein or considered as a warranty covering the use in any manner whatsoever of such third party products or services or any intellectual property contained therein.

**UNLESS OTHERWISE SET FORTH IN ST'S TERMS AND CONDITIONS OF SALE ST DISCLAIMS ANY EXPRESS OR IMPLIED WARRANTY WITH RESPECT TO THE USE AND/OR SALE OF ST PRODUCTS INCLUDING WITHOUT LIMITATION IMPLIED WARRANTIES OF MERCHANTABILITY, FITNESS FOR A PARTICULAR PURPOSE (AND THEIR EQUIVALENTS UNDER THE LAWS OF ANY JURISDICTION), OR INFRINGEMENT OF ANY PATENT, COPYRIGHT OR OTHER INTELLECTUAL PROPERTY RIGHT.**

**UNLESS EXPRESSLY APPROVED IN WRITING BY TWO AUTHORIZED ST REPRESENTATIVES, ST PRODUCTS ARE NOT RECOMMENDED, AUTHORIZED OR WARRANTED FOR USE IN MILITARY, AIR CRAFT, SPACE, LIFE SAVING, OR LIFE SUSTAINING APPLICATIONS, NOR IN PRODUCTS OR SYSTEMS WHERE FAILURE OR MALFUNCTION MAY RESULT IN PERSONAL INJURY, DEATH, OR SEVERE PROPERTY OR ENVIRONMENTAL DAMAGE. ST PRODUCTS WHICH ARE NOT SPECIFIED AS "AUTOMOTIVE GRADE" MAY ONLY BE USED IN AUTOMOTIVE APPLICATIONS AT USER'S OWN RISK.**

Resale of ST products with provisions different from the statements and/or technical features set forth in this document shall immediately void any warranty granted by ST for the ST product or service described herein and shall not create or extend in any manner whatsoever, any liability of ST.

ST and the ST logo are trademarks or registered trademarks of ST in various countries.

Information in this document supersedes and replaces all information previously supplied.

The ST logo is a registered trademark of STMicroelectronics. All other names are the property of their respective owners.

© 2012 STMicroelectronics - All rights reserved

STMicroelectronics group of companies

Australia - Belgium - Brazil - Canada - China - Czech Republic - Finland - France - Germany - Hong Kong - India - Israel - Italy - Japan - Malaysia - Malta - Morocco - Philippines - Singapore - Spain - Sweden - Switzerland - United Kingdom - United States of America

[www.st.com](http://www.st.com)

