

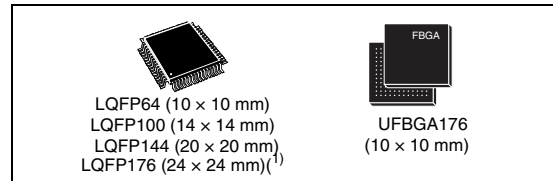


# STM32F215xx STM32F217xx

ARM-based 32-bit MCU, 150DMIPs, up to 1 MB Flash/128+4KB RAM, crypto, USB OTG HS/FS, Ethernet, 17 TIMs, 3 ADCs, 15 comm. interfaces & camera

## Features

- Core: ARM 32-bit Cortex™-M3 CPU with Adaptive real-time accelerator (ART Accelerator™) allowing 0-wait state execution performance from Flash memory, frequency up to 120 MHz, memory protection unit, 150 DMIPS/1.25 DMIPS/MHz (Dhystone 2.1)
- Memories
  - Up to 1 Mbyte of Flash memory
  - 512 bytes of OTP memory
  - Up to 128 + 4 Kbytes of SRAM
  - Flexible static memory controller that supports Compact Flash, SRAM, PSRAM, NOR and NAND memories
  - LCD parallel interface, 8080/6800 modes
- Clock, reset and supply management
  - From 1.8 to 3.6 V application supply and I/Os
  - POR, PDR, PVD and BOR
  - 4 to 26 MHz crystal oscillator
  - Internal 16 MHz factory-trimmed RC (1% accuracy at 25 °C)
  - 32 kHz oscillator for RTC with calibration
  - Internal 32 kHz RC with calibration
- Low power
  - Sleep, Stop and Standby modes
  - V<sub>BAT</sub> supply for RTC, 20 × 32 bit backup registers, and optional 4 KB backup SRAM
- 3 × 12-bit, 0.5 μs A/D converters
  - up to 24 channels
  - up to 6 MSPS in triple interleaved mode
- 2 × 12-bit D/A converters
- General-purpose DMA
  - 16-stream DMA controller with centralized FIFOs and burst support
- Up to 17 timers
  - Up to twelve 16-bit and two 32-bit timers, up to 120 MHz, each with up to 4 IC/OC/PWM or pulse counter and quadrature (incremental) encoder input
- Debug mode
  - Serial wire debug (SWD) & JTAG interfaces
  - Cortex-M3 Embedded Trace Macrocell™



- Up to 140 I/O ports with interrupt capability:
  - Up to 136 fast I/Os up to 60 MHz
  - Up to 138 5 V-tolerant I/Os
- Up to 15 communication interfaces
  - Up to 3 × I<sup>2</sup>C interfaces (SMBus/PMBus)
  - Up to 4 USARTs and 2 UARTs (7.5 Mbit/s, ISO 7816 interface, LIN, IrDA, modem control)
  - Up to 3 SPIs (30 Mbit/s), 2 with muxed I<sup>2</sup>S to achieve audio class accuracy via audio PLL or external PLL
  - 2 × CAN interfaces (2.0B Active)
  - SDIO interface
- Advanced connectivity
  - USB 2.0 full-speed device/host/OTG controller with on-chip PHY
  - USB 2.0 high-speed/full-speed device/host/OTG controller with dedicated DMA, on-chip full-speed PHY and ULPI
  - 10/100 Ethernet MAC with dedicated DMA: supports IEEE 1588v2 hardware, MII/RMII
- 8- to 14-bit parallel camera interface: up to 48 Mbyte/s
- Cryptographic acceleration
  - Hardware acceleration for AES 128, 192, 256, Triple DES, HASH (MD5, SHA-1)
  - Analog true random number generator
- CRC calculation unit
- 96-bit unique ID
- Analog true random number generator

**Table 1. Device summary**

Reference	Part number
STM32F215xx	STM32F215RG, STM32F215VG, STM32F215ZG, STM32F215RE, STM32F215VE, STM32F215ZE
STM32F217xx	STM32F217VG, STM32F217IG, STM32F217ZG, STM32F217VE, STM32F217IE, STM32F217ZE

# Contents

<b>1</b>	<b>Introduction</b>	<b>10</b>
<b>2</b>	<b>Description</b>	<b>11</b>
2.1	Full compatibility throughout the family	13
2.2	Device overview	16
2.2.1	ARM® Cortex™-M3 core with embedded Flash and SRAM	17
2.2.2	Adaptive real-time memory accelerator (ART Accelerator™)	17
2.2.3	Memory protection unit	17
2.2.4	Embedded Flash memory	17
2.2.5	CRC (cyclic redundancy check) calculation unit	18
2.2.6	Embedded SRAM	18
2.2.7	Multi-AHB bus matrix	18
2.2.8	DMA controller (DMA)	19
2.2.9	Flexible static memory controller (FSMC)	19
2.2.10	Nested vectored interrupt controller (NVIC)	20
2.2.11	External interrupt/event controller (EXTI)	20
2.2.12	Clocks and startup	20
2.2.13	Boot modes	21
2.2.14	Power supply schemes	21
2.2.15	Power supply supervisor	21
2.2.16	Voltage regulator	21
2.2.17	Real-time clock (RTC), backup SRAM and backup registers	23
2.2.18	Low-power modes	24
2.2.19	V <sub>BAT</sub> operation	24
2.2.20	Timers and watchdogs	25
2.2.21	Inter-integrated circuit interface (I <sup>2</sup> C)	27
2.2.22	Universal synchronous/asynchronous receiver transmitters (UARTs/USARTs)	27
2.2.23	Serial peripheral interface (SPI)	28
2.2.24	Inter-integrated sound (I <sup>2</sup> S)	28
2.2.25	SDIO	29
2.2.26	Ethernet MAC interface with dedicated DMA and IEEE 1588 support	29
2.2.27	Controller area network (CAN)	30
2.2.28	Universal serial bus on-the-go full-speed (OTG_FS)	30

2.2.29	Universal serial bus on-the-go high-speed (OTG_HS) .....	30
2.2.30	Audio PLL (PLLI2S) .....	31
2.2.31	Digital camera interface (DCMI) .....	31
2.2.32	Cryptographic acceleration .....	32
2.2.33	True random number generator (RNG) .....	32
2.2.34	GPIOs (general-purpose inputs/outputs) .....	33
2.2.35	ADCs (analog-to-digital converters) .....	33
2.2.36	DAC (digital-to-analog converter) .....	33
2.2.37	Temperature sensor .....	34
2.2.38	Serial wire JTAG debug port (SWJ-DP) .....	34
2.2.39	Embedded Trace Macrocell™ .....	34
<b>3</b>	<b>Pinouts and pin description .....</b>	<b>35</b>
<b>4</b>	<b>Memory mapping .....</b>	<b>56</b>
<b>5</b>	<b>Electrical characteristics .....</b>	<b>58</b>
5.1	Parameter conditions .....	58
5.1.1	Minimum and maximum values .....	58
5.1.2	Typical values .....	58
5.1.3	Typical curves .....	58
5.1.4	Loading capacitor .....	58
5.1.5	Pin input voltage .....	58
5.1.6	Power supply scheme .....	59
5.1.7	Current consumption measurement .....	60
5.2	Absolute maximum ratings .....	60
5.3	Operating conditions .....	61
5.3.1	General operating conditions .....	61
5.3.2	VCAP1/VCAP2 external capacitor .....	64
5.3.3	Operating conditions at power-up / power-down (regulator ON) .....	65
5.3.4	Operating conditions at power-up / power-down (regulator OFF) .....	65
5.3.5	Embedded reset and power control block characteristics .....	66
5.3.6	Supply current characteristics .....	67
5.3.7	Wakeup time from low-power mode .....	78
5.3.8	External clock source characteristics .....	79
5.3.9	Internal clock source characteristics .....	83
5.3.10	PLL characteristics .....	84

5.3.11	PLL spread spectrum clock generation (SSCG) characteristics	87
5.3.12	Memory characteristics	88
5.3.13	EMC characteristics	90
5.3.14	Absolute maximum ratings (electrical sensitivity)	92
5.3.15	I/O current injection characteristics	93
5.3.16	I/O port characteristics	94
5.3.17	NRST pin characteristics	98
5.3.18	TIM timer characteristics	99
5.3.19	Communications interfaces	100
5.3.20	12-bit ADC characteristics	113
5.3.21	DAC electrical characteristics	118
5.3.22	Temperature sensor characteristics	120
5.3.23	V <sub>BAT</sub> monitoring characteristics	120
5.3.24	Embedded reference voltage	121
5.3.25	FSMC characteristics	121
5.3.26	Camera interface (DCMI) timing specifications	139
5.3.27	SD/SDIO MMC card host interface (SDIO) characteristics	139
5.3.28	RTC characteristics	140
<b>6</b>	<b>Package characteristics</b>	<b>141</b>
6.1	Package mechanical data	141
6.2	Thermal characteristics	149
<b>7</b>	<b>Part numbering</b>	<b>150</b>
<b>Appendix A</b>	<b>Application block diagrams</b>	<b>151</b>
A.1	Main applications versus package	151
A.2	Application example with regulator OFF	152
A.3	USB OTG full speed (FS) interface solutions	152
A.4	USB OTG high speed (HS) interface solutions	154
A.5	Complete audio player solutions	155
A.6	Ethernet interface solutions	158
<b>8</b>	<b>Revision history</b>	<b>160</b>

## List of tables

Table 1.	Device summary . . . . .	1
Table 2.	STM32F215xx and STM32F217xx: features and peripheral counts . . . . .	12
Table 3.	Timer feature comparison . . . . .	25
Table 4.	USART feature comparison . . . . .	28
Table 5.	STM32F21x pin and ball definitions . . . . .	39
Table 6.	Alternate function mapping . . . . .	51
Table 7.	Voltage characteristics . . . . .	60
Table 8.	Current characteristics . . . . .	61
Table 9.	Thermal characteristics . . . . .	61
Table 10.	General operating conditions . . . . .	61
Table 11.	Limitations depending on the operating power supply range . . . . .	62
Table 12.	VCAP1/VCAP2 operating conditions . . . . .	64
Table 13.	Operating conditions at power-up / power-down (regulator ON) . . . . .	65
Table 14.	Operating conditions at power-up / power-down (regulator OFF) . . . . .	65
Table 15.	Embedded reset and power control block characteristics . . . . .	66
Table 16.	Typical and maximum current consumption in Run mode, code with data processing running from Flash memory (ART accelerator disabled) . . . . .	68
Table 17.	Typical and maximum current consumption in Run mode, code with data processing running from Flash memory (ART accelerator enabled) or RAM . . . . .	69
Table 18.	Typical and maximum current consumption in Sleep mode . . . . .	72
Table 19.	Typical and maximum current consumptions in Stop mode . . . . .	74
Table 20.	Typical and maximum current consumptions in Standby mode . . . . .	75
Table 21.	Typical and maximum current consumptions in V <sub>BAT</sub> mode . . . . .	75
Table 22.	Peripheral current consumption . . . . .	76
Table 23.	Low-power mode wakeup timings . . . . .	78
Table 24.	High-speed external user clock characteristics . . . . .	79
Table 25.	Low-speed external user clock characteristics . . . . .	79
Table 26.	HSE 4-26 MHz oscillator characteristics . . . . .	81
Table 27.	LSE oscillator characteristics (f <sub>LSE</sub> = 32.768 kHz) . . . . .	82
Table 28.	HSI oscillator characteristics . . . . .	83
Table 29.	LSI oscillator characteristics . . . . .	84
Table 30.	Main PLL characteristics . . . . .	84
Table 31.	PLL12S (audio PLL) characteristics . . . . .	85
Table 32.	SSCG parameters constraint . . . . .	87
Table 33.	Flash memory characteristics . . . . .	88
Table 34.	Flash memory programming . . . . .	89
Table 35.	Flash memory programming with V <sub>PP</sub> . . . . .	90
Table 36.	Flash memory endurance and data retention . . . . .	90
Table 37.	EMS characteristics . . . . .	91
Table 38.	EMI characteristics . . . . .	92
Table 39.	ESD absolute maximum ratings . . . . .	92
Table 40.	Electrical sensitivities . . . . .	93
Table 41.	I/O current injection susceptibility . . . . .	93
Table 42.	I/O static characteristics . . . . .	94
Table 43.	Output voltage characteristics . . . . .	95
Table 44.	I/O AC characteristics . . . . .	96
Table 45.	NRST pin characteristics . . . . .	98
Table 46.	Characteristics of TIMx connected to the APB1 domain . . . . .	99

Table 47.	Characteristics of TIMx connected to the APB2 domain	100
Table 48.	I <sup>2</sup> C characteristics	101
Table 49.	SCL frequency (f <sub>PCLK1</sub> = 30 MHz, V <sub>DD</sub> = 3.3 V)	102
Table 50.	SPI characteristics	103
Table 51.	I <sup>2</sup> S characteristics	106
Table 52.	USB OTG FS startup time	108
Table 53.	USB OTG FS DC electrical characteristics	108
Table 54.	USB OTG FS electrical characteristics	109
Table 55.	USB HS DC electrical characteristics	109
Table 56.	Clock timing parameters	109
Table 57.	ULPI timing	110
Table 58.	Ethernet DC electrical characteristics	110
Table 59.	Dynamics characteristics: Ethernet MAC signals for SMI	111
Table 60.	Dynamics characteristics: Ethernet MAC signals for RMII	111
Table 61.	Dynamics characteristics: Ethernet MAC signals for MII	112
Table 62.	ADC characteristics	113
Table 63.	ADC accuracy	115
Table 64.	DAC characteristics	118
Table 65.	TS characteristics	120
Table 66.	V <sub>BAT</sub> monitoring characteristics	120
Table 67.	Embedded internal reference voltage	121
Table 68.	Asynchronous non-multiplexed SRAM/PSRAM/NOR read timings	122
Table 69.	Asynchronous non-multiplexed SRAM/PSRAM/NOR write timings	123
Table 70.	Asynchronous multiplexed PSRAM/NOR read timings	124
Table 71.	Asynchronous multiplexed PSRAM/NOR write timings	125
Table 72.	Synchronous multiplexed NOR/PSRAM read timings	127
Table 73.	Synchronous multiplexed PSRAM write timings	128
Table 74.	Synchronous non-multiplexed NOR/PSRAM read timings	129
Table 75.	Synchronous non-multiplexed PSRAM write timings	130
Table 76.	Switching characteristics for PC Card/CF read and write cycles in attribute/common space	135
Table 77.	Switching characteristics for PC Card/CF read and write cycles in I/O space	136
Table 78.	Switching characteristics for NAND Flash read cycles	138
Table 79.	Switching characteristics for NAND Flash write cycles	139
Table 80.	DCMI characteristics	139
Table 81.	SD / MMC characteristics	140
Table 82.	RTC characteristics	140
Table 83.	LQFP64 – 10 x 10 mm 64 pin low-profile quad flat package mechanical data	142
Table 84.	LQFP100 – 14 x 14 mm 100-pin low-profile quad flat package mechanical data	143
Table 85.	LQFP144 20 x 20 mm, 144-pin low-profile quad flat package mechanical data	144
Table 86.	LQFP176 - Low profile quad flat package 24 x 24 x 1.4 mm package mechanical data	145
Table 87.	UFBGA176+25 - ultra thin fine pitch ball grid array 10 x 10 x 0.6 mm mechanical data	147
Table 88.	Package thermal characteristics	149
Table 89.	Ordering information scheme	150
Table 90.	Main applications versus package for STM32F2xxx microcontrollers	151
Table 91.	Document revision history	160

## List of figures

Figure 1.	Compatible board design between STM32F10xx and STM32F2xx for LQFP64 package. . . . .	13
Figure 2.	Compatible board design between STM32F10xx and STM32F2xx for LQFP100 package. . . . .	14
Figure 3.	Compatible board design between STM32F10xx and STM32F2xx for LQFP144 package. . . . .	14
Figure 4.	Compatible board design between STM32F10xx and STM32F2xx for LQFP176 package. . . . .	15
Figure 5.	STM32F21x block diagram. . . . .	16
Figure 6.	Multi-AHB matrix. . . . .	18
Figure 7.	Startup in regulator OFF: slow $V_{DD}$ slope - power-down reset risen after $V_{CAP\_1}/V_{CAP\_2}$ stabilization . . . . .	22
Figure 8.	Startup in regulator OFF: fast $V_{DD}$ slope - power-down reset risen before $V_{CAP\_1}/V_{CAP\_2}$ stabilization . . . . .	23
Figure 9.	STM32F21x LQFP64 pinout . . . . .	35
Figure 10.	STM32F21x LQFP100 pinout . . . . .	36
Figure 11.	STM32F21x LQFP144 pinout . . . . .	37
Figure 12.	STM32F21x LQFP176 pinout . . . . .	38
Figure 13.	STM32F21x UFBGA176 ballout . . . . .	39
Figure 14.	Memory map. . . . .	57
Figure 15.	Pin loading conditions. . . . .	58
Figure 16.	Pin input voltage . . . . .	58
Figure 17.	Power supply scheme . . . . .	59
Figure 18.	Current consumption measurement scheme . . . . .	60
Figure 19.	Number of wait states versus $f_{CPU}$ and $V_{DD}$ range. . . . .	64
Figure 20.	External capacitor $C_{EXT}$ . . . . .	64
Figure 21.	Typical current consumption vs temperature, Run mode, code with data processing running from RAM, and peripherals ON. . . . .	70
Figure 22.	Typical current consumption vs temperature, Run mode, code with data processing running from RAM, and peripherals OFF . . . . .	70
Figure 23.	Typical current consumption vs temperature, Run mode, code with data processing running from Flash, ART accelerator OFF, peripherals ON . . . . .	71
Figure 24.	Typical current consumption vs temperature, Run mode, code with data processing running from Flash, ART accelerator OFF, peripherals OFF . . . . .	71
Figure 25.	Typical current consumption vs temperature in Sleep mode, peripherals ON . . . . .	73
Figure 26.	Typical current consumption vs temperature in Sleep mode, peripherals OFF . . . . .	73
Figure 27.	Typical current consumption vs temperature in Stop mode . . . . .	74
Figure 28.	High-speed external clock source AC timing diagram . . . . .	80
Figure 29.	Low-speed external clock source AC timing diagram. . . . .	80
Figure 30.	Typical application with an 8 MHz crystal . . . . .	81
Figure 31.	Typical application with a 32.768 kHz crystal . . . . .	82
Figure 32.	$ACC_{HSI}$ versus temperature . . . . .	83
Figure 33.	$ACC_{LSI}$ versus temperature . . . . .	84
Figure 34.	PLL output clock waveforms in center spread mode . . . . .	88
Figure 35.	PLL output clock waveforms in down spread mode . . . . .	88
Figure 36.	I/O AC characteristics definition . . . . .	97

Figure 37.	Recommended NRST pin protection . . . . .	98
Figure 38.	I <sup>2</sup> C bus AC waveforms and measurement circuit . . . . .	102
Figure 39.	SPI timing diagram - slave mode and CPHA = 0 . . . . .	104
Figure 40.	SPI timing diagram - slave mode and CPHA = 1 <sup>(1)</sup> . . . . .	104
Figure 41.	SPI timing diagram - master mode <sup>(1)</sup> . . . . .	105
Figure 42.	I <sup>2</sup> S slave timing diagram (Philips protocol) <sup>(1)</sup> . . . . .	107
Figure 43.	I <sup>2</sup> S master timing diagram (Philips protocol) <sup>(1)</sup> . . . . .	107
Figure 44.	USB OTG FS timings: definition of data signal rise and fall time . . . . .	109
Figure 45.	ULPI timing diagram . . . . .	110
Figure 46.	Ethernet SMI timing diagram . . . . .	111
Figure 47.	Ethernet RMII timing diagram . . . . .	111
Figure 48.	Ethernet MII timing diagram . . . . .	112
Figure 49.	ADC accuracy characteristics . . . . .	115
Figure 50.	Typical connection diagram using the ADC . . . . .	116
Figure 51.	Power supply and reference decoupling (V <sub>REF+</sub> not connected to V <sub>DDA</sub> ) . . . . .	117
Figure 52.	Power supply and reference decoupling (V <sub>REF+</sub> connected to V <sub>DDA</sub> ) . . . . .	117
Figure 53.	12-bit buffered /non-buffered DAC . . . . .	120
Figure 54.	Asynchronous non-multiplexed SRAM/PSRAM/NOR read waveforms . . . . .	122
Figure 55.	Asynchronous non-multiplexed SRAM/PSRAM/NOR write waveforms . . . . .	123
Figure 56.	Asynchronous multiplexed PSRAM/NOR read waveforms . . . . .	124
Figure 57.	Asynchronous multiplexed PSRAM/NOR write waveforms . . . . .	125
Figure 58.	Synchronous multiplexed NOR/PSRAM read timings . . . . .	126
Figure 59.	Synchronous multiplexed PSRAM write timings . . . . .	128
Figure 60.	Synchronous non-multiplexed NOR/PSRAM read timings . . . . .	129
Figure 61.	Synchronous non-multiplexed PSRAM write timings . . . . .	130
Figure 62.	PC Card/CompactFlash controller waveforms for common memory read access . . . . .	131
Figure 63.	PC Card/CompactFlash controller waveforms for common memory write access . . . . .	132
Figure 64.	PC Card/CompactFlash controller waveforms for attribute memory read access . . . . .	133
Figure 65.	PC Card/CompactFlash controller waveforms for attribute memory write access . . . . .	134
Figure 66.	PC Card/CompactFlash controller waveforms for I/O space read access . . . . .	134
Figure 67.	PC Card/CompactFlash controller waveforms for I/O space write access . . . . .	135
Figure 68.	NAND controller waveforms for read access . . . . .	137
Figure 69.	NAND controller waveforms for write access . . . . .	137
Figure 70.	NAND controller waveforms for common memory read access . . . . .	138
Figure 71.	NAND controller waveforms for common memory write access . . . . .	138
Figure 72.	SDIO high-speed mode . . . . .	139
Figure 73.	SD default mode . . . . .	140
Figure 74.	LQFP64 – 10 x 10 mm 64 pin low-profile quad flat package outline . . . . .	142
Figure 75.	Recommended footprint <sup>(1)</sup> . . . . .	142
Figure 76.	LQFP100, 14 x 14 mm 100-pin low-profile quad flat package outline . . . . .	143
Figure 77.	Recommended footprint <sup>(1)</sup> . . . . .	143
Figure 78.	LQFP144, 20 x 20 mm, 144-pin low-profile quad flat package outline . . . . .	144
Figure 79.	Recommended footprint <sup>(1)</sup> . . . . .	144
Figure 80.	LQFP176 - Low profile quad flat package 24 x 24 x 1.4 mm, package outline . . . . .	145
Figure 81.	UFBGA176+25 - ultra thin fine pitch ball grid array 10 x 10 x 0.6 mm, package outline . . . . .	147
Figure 82.	Regulator OFF/internal reset ON . . . . .	152
Figure 83.	USB OTG FS (full speed) device-only connection . . . . .	152
Figure 84.	USB OTG FS (full speed) host-only connection . . . . .	153
Figure 85.	OTG FS (full speed) connection dual-role with internal PHY . . . . .	153



---

Figure 86.	OTG HS (high speed) device connection, host and dual-role in high-speed mode with external PHY. ....	154
Figure 87.	Complete audio player solution 1 . . . . .	155
Figure 88.	Complete audio player solution 2 . . . . .	155
Figure 89.	Audio player solution using PLL, PLLI2S, USB and 1 crystal. ....	156
Figure 90.	Audio PLL (PLLI2S) providing accurate I2S clock . . . . .	156
Figure 91.	Master clock (MCK) used to drive the external audio DAC. ....	157
Figure 92.	Master clock (MCK) not used to drive the external audio DAC. ....	157
Figure 93.	MII mode using a 25 MHz crystal . . . . .	158
Figure 94.	RMII with a 50 MHz oscillator . . . . .	158
Figure 95.	RMII with a 25 MHz crystal and PHY with PLL. ....	159

# 1 Introduction

This datasheet provides the description of the STM32F215xx, and STM32F217xx lines of microcontrollers. For more details on the whole STMicroelectronics STM32™ family, please refer to [Section 2.1: Full compatibility throughout the family](#).

The STM32F215xx, and STM32F217xx datasheet should be read in conjunction with the STM32F20x/STM32F21x reference manual. They will be referred to as STM32F21x devices throughout the document.

For information on programming, erasing and protection of the internal Flash memory, please refer to the STM32F20x/STM32F21x Flash programming manual (PM0059).

The reference and Flash programming manuals are both available from the STMicroelectronics website [www.st.com](http://www.st.com).

For information on the Cortex™-M3 core please refer to the Cortex™-M3 Technical Reference Manual, available from the [www.arm.com](http://www.arm.com) website at the following address: <http://infocenter.arm.com/help/index.jsp?topic=/com.arm.doc.ddi0337e/>.

## 2 Description

The STM32F21x family is based on the high-performance ARM® Cortex™-M3 32-bit RISC core operating at a frequency of up to 120 MHz. The family incorporates high-speed embedded memories (Flash memory up to 1 Mbyte, up to 128 Kbytes of system SRAM), up to 4 Kbytes of backup SRAM, and an extensive range of enhanced I/Os and peripherals connected to two APB buses, two AHB buses and a 32-bit multi-AHB bus matrix.

The devices also feature an adaptive real-time memory accelerator (ART Accelerator™) which allows to achieve a performance equivalent to 0 wait state program execution from Flash memory at a CPU frequency up to 120 MHz. This performance has been validated using the CoreMark benchmark.

All devices offer three 12-bit ADCs, two DACs, a low-power RTC, twelve general-purpose 16-bit timers including two PWM timers for motor control, two general-purpose 32-bit timers, a true number random generator (RNG). They also feature standard and advanced communication interfaces. New advanced peripherals include an SDIO, an enhanced flexible static memory control (FSMC) interface (for devices offered in packages of 100 pins and more), a cryptographic acceleration cell, and a camera interface for CMOS sensors. The devices also feature standard peripherals.

- Up to three I<sup>2</sup>Cs
- Three SPIs, two I<sup>2</sup>Ss. To achieve audio class accuracy, the I<sup>2</sup>S peripherals can be clocked via a dedicated internal audio PLL or via an external PLL to allow synchronization.
- 4 USARTs and 2 UARTs
- A USB OTG full-speed with high-speed capability (with the ULPI)
- Two CANs
- An SDIO interface
- Ethernet and camera interface available on STM32F217xx devices only.

*The STM32F215xx and STM32F217xx devices operate in the –40 to +105 °C temperature range from a 1.8 V to 3.6 V power supply.* A comprehensive set of power-saving modes allow the design of low-power applications.

STM32F215xx and STM32F217xx devices are offered in four packages ranging from 64 pins to 176 pins. The set of included peripherals changes with the device chosen. These features make the STM32F215xx and STM32F217xx microcontroller family suitable for a wide range of applications:

- Motor drive and application control
- Medical equipment
- Industrial applications: PLC, inverters, circuit breakers
- Printers, and scanners
- Alarm systems, video intercom, and HVAC
- Home audio appliances

*Figure 5* shows the general block diagram of the device family.



**Table 2. STM32F215xx and STM32F217xx: features and peripheral counts**

Peripherals		STM32F215Rx		STM32F215Vx		STM32F215Zx		STM32F217Vx		STM32F217Zx		STM32F217Ix	
Flash memory in Kbytes		512	1024	512	1024	512	1024	512	1024	512	1024	512	1024
SRAM in Kbytes	System	128(112+16)											
	Backup	4		4		4		4		4		4	
FSMC memory controller		No				Yes							
Ethernet		No						Yes					
Timers	General-purpose	10											
	Advanced-control	2											
	Basic	2											
Random number generator		Yes											
Communication interfaces	SPI / (I <sup>2</sup> S)	3 (2)											
	I <sup>2</sup> C	3											
	USART	4											
	UART	2											
	USB OTG FS	No						1					
	USB OTG HS	1											
CAN		2											
Camera interface		No						Yes					
Encryption		Yes											
GPIOs		51		82		114		82		114		140	
SDIO		Yes											
12-bit ADC		3											
Number of channels		16		16		24		16		24		24	
12-bit DAC		Yes											
Number of channels		2											
Maximum CPU frequency		120 MHz											
Operating voltage		1.8 V to 3.6 V											
Operating temperatures		Ambient temperatures: -40 to +85 °C / -40 to +105 °C											
		Junction temperature: -40 to +125 °C											
Package		LQFP64		LQFP100		LQFP144		LQFP100		LQFP144		UFBGA176 LQFP176	

Doc ID 17050 Rev 6

12/168

STM32F215xx, STM32F217xx

Description

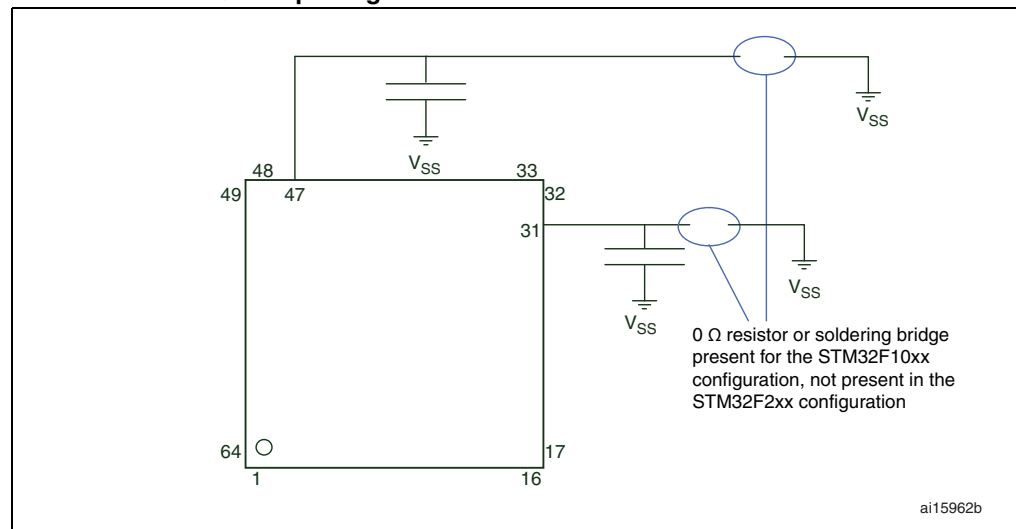
## 2.1 Full compatibility throughout the family

The STM32F215xx and STM32F217xx constitute the STM32F21x family whose members are fully pin-to-pin, software and feature compatible, allowing the user to try different memory densities and peripherals for a greater degree of freedom during the development cycle.

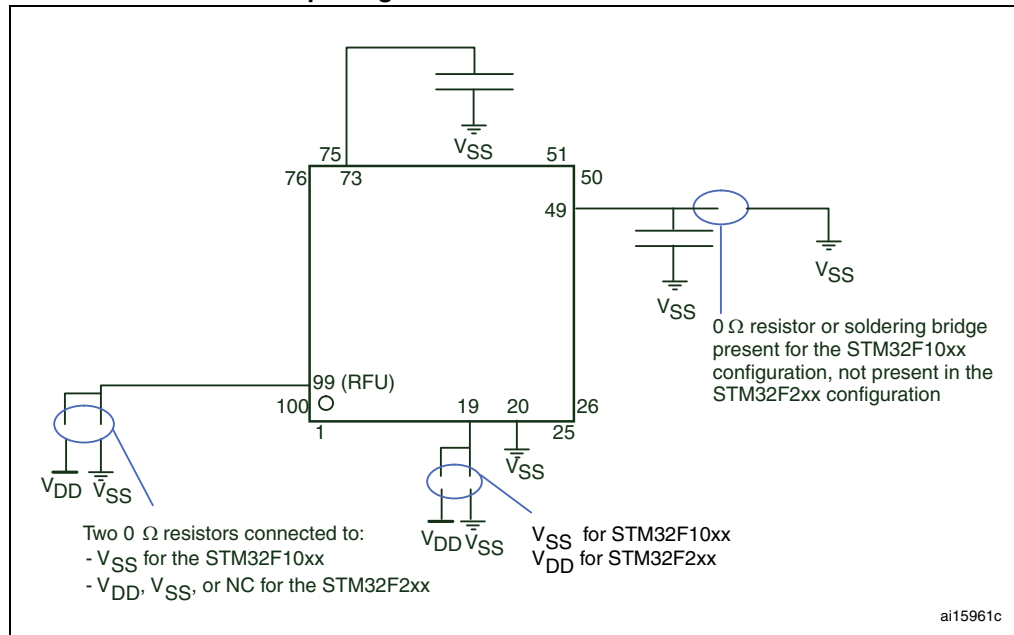
The STM32F215xx and STM32F217xx devices maintain a close compatibility with the whole STM32F10xxx family. All functional pins are pin-to-pin compatible. The STM32F215xx and STM32F217xx, however, are not drop-in replacements for the STM32F10xxx devices: the two families do not have the same power scheme, and so their power pins are different. Nonetheless, transition from the STM32F10xxx to the STM32F21x family remains simple as only a few pins are impacted.

[Figure 3](#), [Figure 4](#), and [Figure 1](#) provide compatible board designs between the STM32F21x and the STM32F10xxx family.

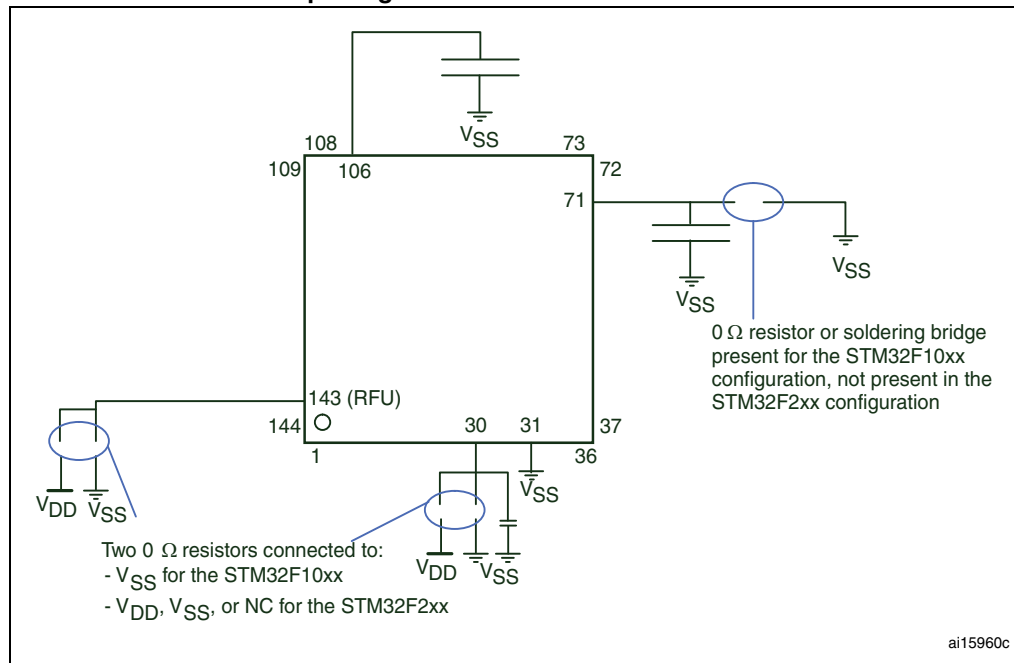
**Figure 1. Compatible board design between STM32F10xx and STM32F2xx for LQFP64 package**



**Figure 2. Compatible board design between STM32F10xx and STM32F2xx for LQFP100 package**

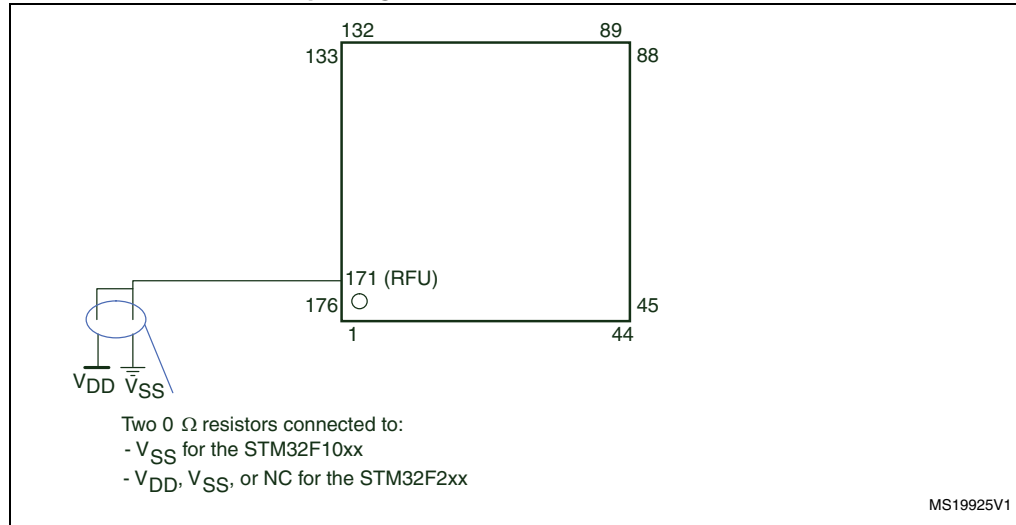


**Figure 3. Compatible board design between STM32F10xx and STM32F2xx for LQFP144 package**



1. RFU = reserved for future use.

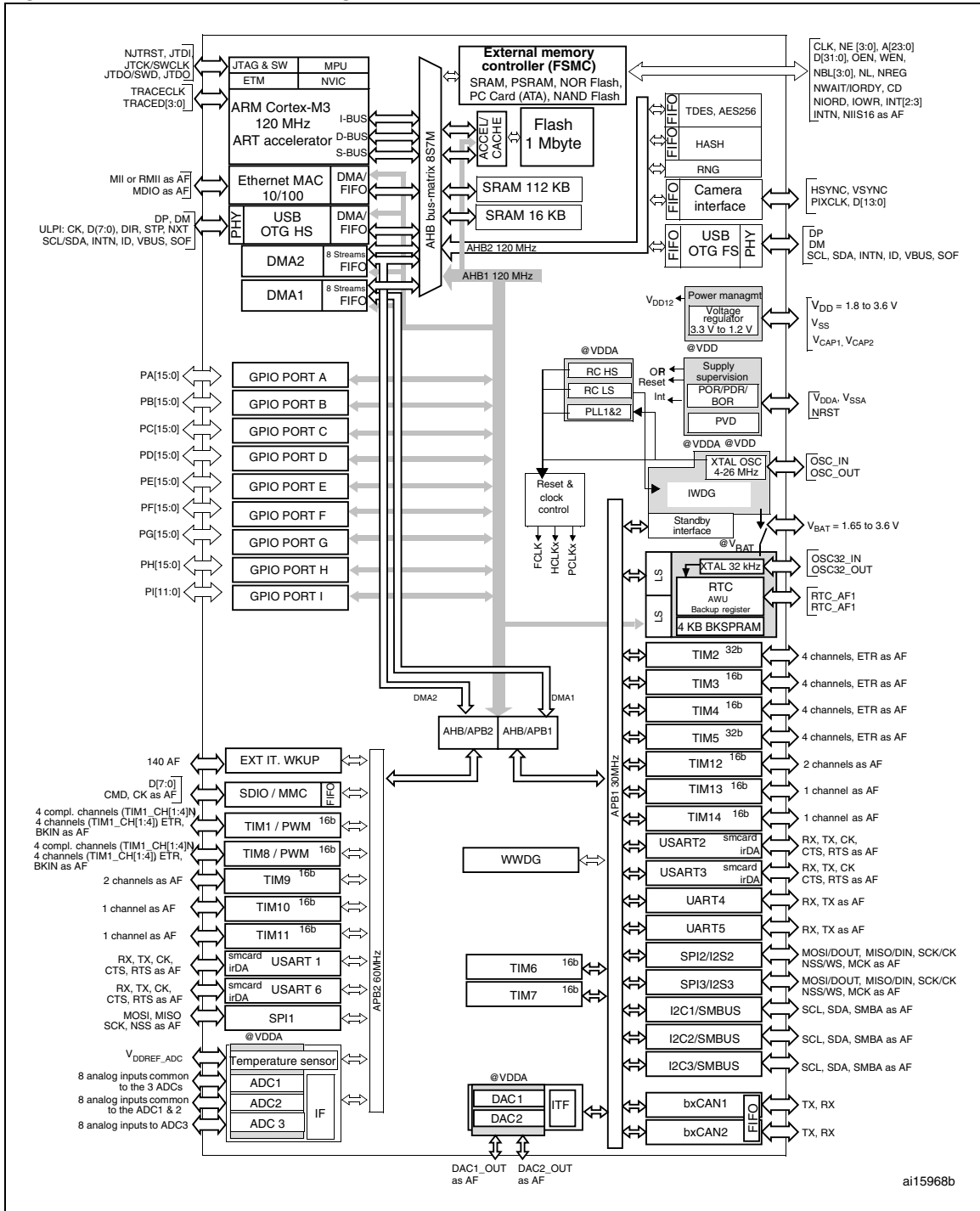
**Figure 4. Compatible board design between STM32F10xx and STM32F2xx for LQFP176 package**



1. RFU = reserved for future use.

## 2.2 Device overview

Figure 5. STM32F21x block diagram



1. The timers connected to APB2 are clocked from TIMxCLK up to 120 MHz, while the timers connected to APB1 are clocked from TIMxCLK up to 60 MHz.



### 2.2.1 ARM® Cortex™-M3 core with embedded Flash and SRAM

The ARM Cortex-M3 processor is the latest generation of ARM processors for embedded systems. It was developed to provide a low-cost platform that meets the needs of MCU implementation, with a reduced pin count and low-power consumption, while delivering outstanding computational performance and an advanced response to interrupts.

The ARM Cortex-M3 32-bit RISC processor features exceptional code-efficiency, delivering the high-performance expected from an ARM core in the memory size usually associated with 8- and 16-bit devices.

With its embedded ARM core, the STM32F21x family is compatible with all ARM tools and software.

*Figure 5* shows the general block diagram of the STM32F21x family.

### 2.2.2 Adaptive real-time memory accelerator (ART Accelerator™)

The ART Accelerator™ is a memory accelerator which is optimized for STM32 industry-standard ARM® Cortex™-M3 processors. It balances the inherent performance advantage of the ARM Cortex-M3 over Flash memory technologies, which normally requires the processor to wait for the Flash memory at higher operating frequencies.

To release the processor full 150 DMIPS performance at this frequency, the accelerator implements an instruction prefetch queue and branch cache which increases program execution speed from the 128-bit Flash memory. Based on CoreMark benchmark, the performance achieved thanks to the ART accelerator is equivalent to 0 wait state program execution from Flash memory at a CPU frequency up to 120 MHz.

### 2.2.3 Memory protection unit

The memory protection unit (MPU) is used to manage the CPU accesses to memory to prevent one task to accidentally corrupt the memory or resources used by any other active task. This memory area is organized into up to 8 protected areas that can in turn be divided up into 8 subareas. The protection area sizes are between 32 bytes and the whole 4 gigabytes of addressable memory.

The MPU is especially helpful for applications where some critical or certified code has to be protected against the misbehavior of other tasks. It is usually managed by an RTOS (real-time operating system). If a program accesses a memory location that is prohibited by the MPU, the RTOS can detect it and take action. In an RTOS environment, the kernel can dynamically update the MPU area setting, based on the process to be executed.

The MPU is optional and can be bypassed for applications that do not need it.

### 2.2.4 Embedded Flash memory

The STM32F21x devices embed a 128-bit wide Flash memory of 128 Kbytes, 256 Kbytes, 512 Kbytes, 768 Kbytes or 1 Mbytes available for storing programs and data.

The devices also feature 512 bytes of OTP memory that can be used to store critical user data such as Ethernet MAC addresses or cryptographic keys.

## 2.2.5 CRC (cyclic redundancy check) calculation unit

The CRC (cyclic redundancy check) calculation unit is used to get a CRC code from a 32-bit data word and a fixed generator polynomial.

Among other applications, CRC-based techniques are used to verify data transmission or storage integrity. In the scope of the EN/IEC 60335-1 standard, they offer a means of verifying the Flash memory integrity. The CRC calculation unit helps compute a software signature during runtime, to be compared with a reference signature generated at link-time and stored at a given memory location.

## 2.2.6 Embedded SRAM

All STM32F21x products embed:

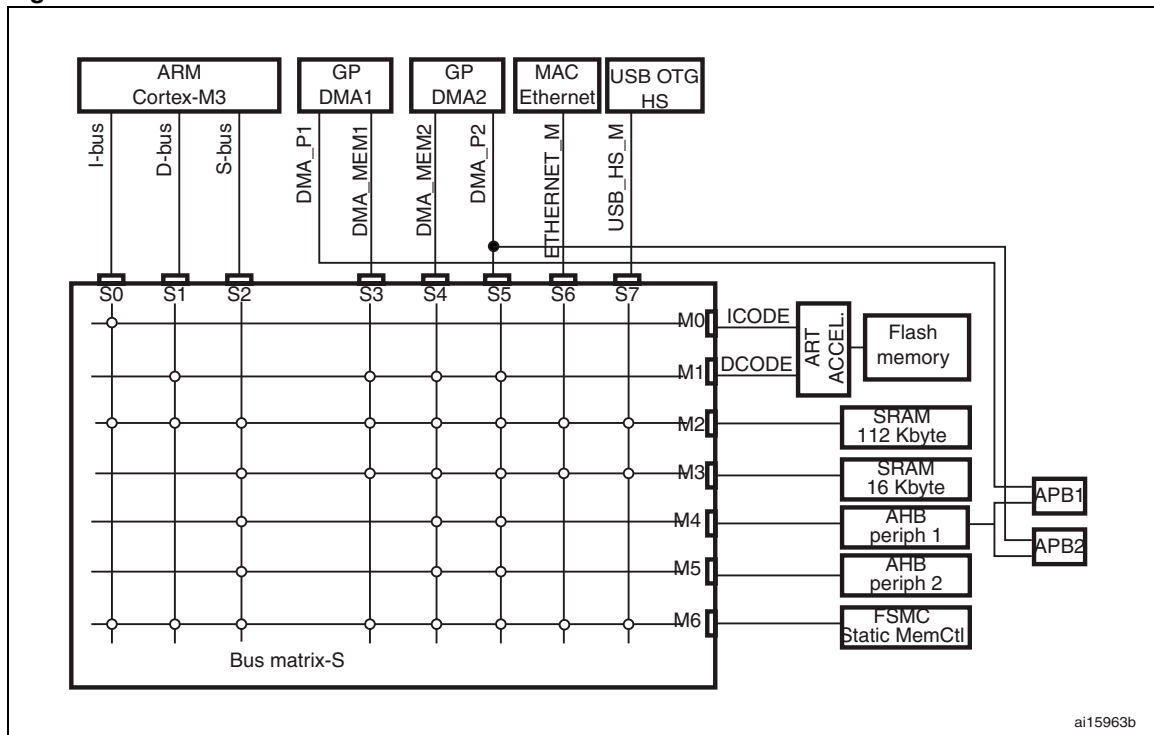
- Up to 128 Kbytes of system SRAM accessed (read/write) at CPU clock speed with 0 wait states
- 4 Kbytes of backup SRAM.

The content of this area is protected against possible unwanted write accesses, and is retained in Standby or VBAT mode.

## 2.2.7 Multi-AHB bus matrix

The 32-bit multi-AHB bus matrix interconnects all the masters (CPU, DMAs, Ethernet, USB HS) and the slaves (Flash memory, RAM, FSMC, AHB and APB peripherals) and ensures a seamless and efficient operation even when several high-speed peripherals work simultaneously.

Figure 6. Multi-AHB matrix



### 2.2.8 DMA controller (DMA)

The devices feature two general-purpose dual-port DMAs (DMA1 and DMA2) with 8 streams each. They are able to manage memory-to-memory, peripheral-to-memory and memory-to-peripheral transfers. They share some centralized FIFOs for APB/AHB peripherals, support burst transfer and are designed to provide the maximum peripheral bandwidth (AHB/APB).

The two DMA controllers support circular buffer management, so that no specific code is needed when the controller reaches the end of the buffer. The two DMA controllers also have a double buffering feature, which automates the use and switching of two memory buffers without requiring any special code.

Each stream is connected to dedicated hardware DMA requests, with support for software trigger on each stream. Configuration is made by software and transfer sizes between source and destination are independent.

The DMA can be used with the main peripherals:

- SPI and I<sup>2</sup>S
- I<sup>2</sup>C
- USART and UART
- General-purpose, basic and advanced-control timers TIMx
- DAC
- SDIO
- Cryptographic acceleration
- Camera interface (DCMI)
- ADC.

### 2.2.9 Flexible static memory controller (FSMC)

The FSMC is embedded in all STM32F21x devices. It has four Chip Select outputs supporting the following modes: PC Card/Compact Flash, SRAM, PSRAM, NOR Flash and NAND Flash.

Functionality overview:

- Write FIFO
- Code execution from external memory except for NAND Flash and PC Card
- Maximum frequency ( $f_{\text{HCLK}}$ ) for external access is 60 MHz

#### LCD parallel interface

The FSMC can be configured to interface seamlessly with most graphic LCD controllers. It supports the Intel 8080 and Motorola 6800 modes, and is flexible enough to adapt to specific LCD interfaces. This LCD parallel interface capability makes it easy to build cost-effective graphic applications using LCD modules with embedded controllers or high performance solutions using external controllers with dedicated acceleration.

### 2.2.10 Nested vectored interrupt controller (NVIC)

The STM32F215xx and STM32F217xx embed a nested vectored interrupt controller able to manage 16 priority levels, and handle up to 87 maskable interrupt channels plus the 16 interrupt lines of the Cortex™-M3.

The NVIC main features are the following:

- Closely coupled NVIC gives low-latency interrupt processing
- Interrupt entry vector table address passed directly to the core
- Closely coupled NVIC core interface
- Allows early processing of interrupts
- Processing of late arriving, higher-priority interrupts
- Support tail chaining
- Processor state automatically saved
- Interrupt entry restored on interrupt exit with no instruction overhead

This hardware block provides flexible interrupt management features with minimum interrupt latency.

### 2.2.11 External interrupt/event controller (EXTI)

The external interrupt/event controller consists of 23 edge-detector lines used to generate interrupt/event requests. Each line can be independently configured to select the trigger event (rising edge, falling edge, both) and can be masked independently. A pending register maintains the status of the interrupt requests. The EXTI can detect an external line with a pulse width shorter than the Internal APB2 clock period. Up to 140 GPIOs can be connected to the 16 external interrupt lines.

### 2.2.12 Clocks and startup

On reset the 16 MHz internal RC oscillator is selected as the default CPU clock. The 16 MHz internal RC oscillator is factory-trimmed to offer 1% accuracy. The application can then select as system clock either the RC oscillator or an external 4-26 MHz clock source. This clock is monitored for failure. If failure is detected, the system automatically switches back to the internal RC oscillator and a software interrupt is generated (if enabled). Similarly, full interrupt management of the PLL clock entry is available when necessary (for example if an indirectly used external oscillator fails).

The advanced clock controller clocks the core and all peripherals using a single crystal or oscillator. In particular, the ethernet and USB OTG FS peripherals can be clocked by the system clock.

Several prescalers and PLLs allow the configuration of the two AHB buses, the high-speed APB (APB2) and the low-speed APB (APB1) domains. The maximum frequency of the two AHB buses is 120 MHz and the maximum frequency the high-speed APB domains is 60 MHz. The maximum allowed frequency of the low-speed APB domain is 30 MHz.

The devices embed a dedicate PLL (PLL12S) which allow to achieve audio class performance. In this case, the I<sup>2</sup>S master clock can generate all standard sampling frequencies from 8 kHz to 192 kHz.

### 2.2.13 Boot modes

At startup, boot pins are used to select one out of three boot options:

- Boot from user Flash
- Boot from system memory
- Boot from embedded SRAM

The boot loader is located in system memory. It is used to reprogram the Flash memory by using USART1 (PA9/PA10), USART3 (PC10/PC11 or PB10/PB11), CAN2 (PB5/PB13), USB OTG FS in Device mode (PA11/PA12) through DFU (device firmware upgrade).

### 2.2.14 Power supply schemes

- $V_{DD} = 1.8$  to  $3.6$  V: external power supply for I/Os and the internal regulator (when enabled), provided externally through  $V_{DD}$  pins.
- $V_{SSA}$ ,  $V_{DDA} = 1.8$  to  $3.6$  V: external analog power supplies for ADC, DAC, Reset blocks, RCs and PLL.  $V_{DDA}$  and  $V_{SSA}$  must be connected to  $V_{DD}$  and  $V_{SS}$ , respectively.
- $V_{BAT} = 1.65$  to  $3.6$  V: power supply for RTC, external clock, 32 kHz oscillator and backup registers (through power switch) when  $V_{DD}$  is not present.

Refer to [Figure 17: Power supply scheme](#) for more details.

### 2.2.15 Power supply supervisor

The devices have an integrated power-on reset (POR) / power-down reset (PDR) circuitry coupled with a Brownout reset (BOR) circuitry. At power-on, BOR is always active, and ensures proper operation starting from 1.8 V. After the 1.8 V BOR threshold is reached, the option byte loading process starts, either to confirm or modify default thresholds, or to disable BOR permanently. Three BOR thresholds are available through option bytes. The device remains in reset mode when  $V_{DD}$  is below a specified threshold,  $V_{POR/PDR}$  or  $V_{BOR}$ , without the need for an external reset circuit.

The devices also feature an embedded programmable voltage detector (PVD) that monitors the  $V_{DD}/V_{DDA}$  power supply and compares it to the  $V_{PVD}$  threshold. An interrupt can be generated when  $V_{DD}/V_{DDA}$  drops below the  $V_{PVD}$  threshold and/or when  $V_{DD}/V_{DDA}$  is higher than the  $V_{PVD}$  threshold. The interrupt service routine can then generate a warning message and/or put the MCU into a safe state. The PVD is enabled by software.

### 2.2.16 Voltage regulator

The regulator has four operating modes:

- Regulator ON
  - Main regulator mode (MR)
  - Low power regulator (LPR)
  - Power-down
- Regulator OFF
  - Regulator OFF/internal reset ON

## Regulator ON

The regulator ON modes are activated by default on LQFP packages. On UFBGA176 package, they are activated by connecting REGOFF to  $V_{SS}$ .

$V_{DD}$  minimum value is 1.8 V.

There are three regulator ON modes:

- MR is used in nominal regulation mode (Run)
- LPR is used in Stop mode
- Power-down is used in Standby mode:

The regulator output is in high impedance: the kernel circuitry is powered down, inducing zero consumption (but the contents of the registers and SRAM are lost).

## Regulator OFF

- Regulator OFF/internal reset ON

On UFBGA176 package, REGOFF must be connected to  $V_{DD}$ .

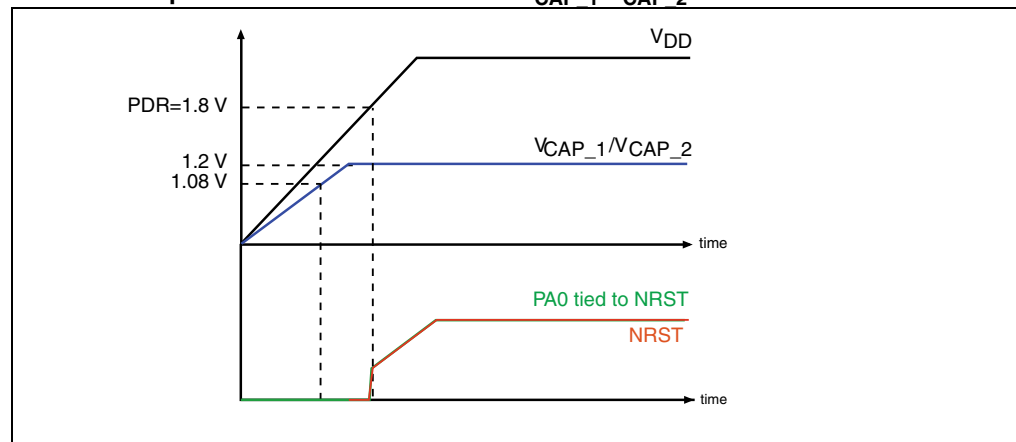
The regulator OFF/internal reset ON mode allows to supply externally a 1.2 V voltage source through  $V_{CAP\_1}$  and  $V_{CAP\_2}$  pins, in addition to  $V_{DD}$ .

The following conditions must be respected:

- $V_{DD}$  should always be higher than  $V_{CAP\_1}$  and  $V_{CAP\_2}$  to avoid current injection between power domains.
- If the time for  $V_{CAP\_1}$  and  $V_{CAP\_2}$  to reach 1.08 V is faster than the time for  $V_{DD}$  to reach 1.8 V, then PA0 should be connected to the NRST pin (see [Figure 7](#)). Otherwise, PA0 should be asserted low externally during POR until  $V_{DD}$  reaches 1.8 V (see [Figure 8](#)).

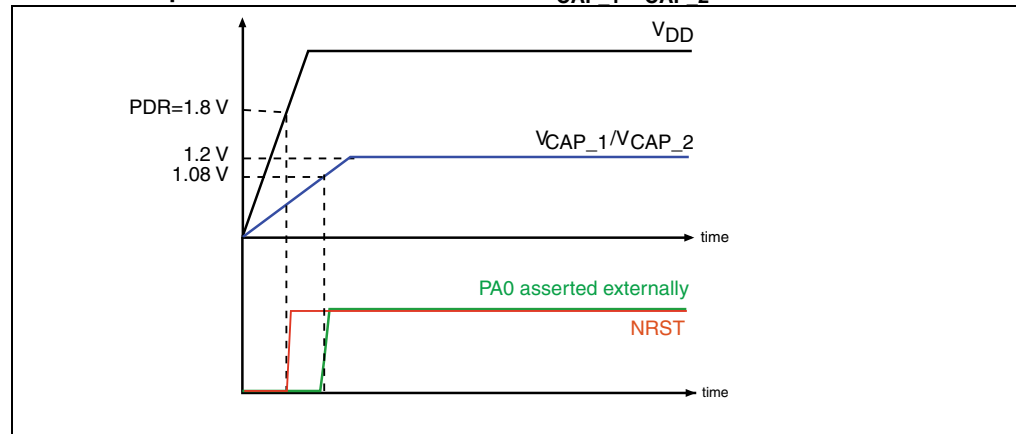
In this mode, PA0 cannot be used as a GPIO pin since it allows to reset the part of the 1.2 V logic which is not reset by the NRST pin, when the internal voltage regulator is OFF.

**Figure 7. Startup in regulator OFF: slow  $V_{DD}$  slope - power-down reset risen after  $V_{CAP\_1}/V_{CAP\_2}$  stabilization**



1. This figure is valid both whatever the internal reset mode (ON or OFF).

**Figure 8. Startup in regulator OFF: fast  $V_{DD}$  slope  
- power-down reset risen before  $V_{CAP\_1}/V_{CAP\_2}$  stabilization**



### 2.2.17 Real-time clock (RTC), backup SRAM and backup registers

The backup domain of the STM32F21x devices includes:

- The real-time clock (RTC)
- 4 Kbytes of backup SRAM
- 20 backup registers

The real-time clock (RTC) is an independent BCD timer/counter. Dedicated registers contain the second, minute, hour (in 12/24 hour), week day, date, month, year, in BCD (binary-coded decimal) format. Correction for 28, 29 (leap year), 30, and 31 day of the month are performed automatically. The RTC provides a programmable alarm and programmable periodic interrupts with wakeup from Stop and Standby modes.

It is clocked by a 32.768 kHz external crystal, resonator or oscillator, the internal low-power RC oscillator or the high-speed external clock divided by 128. The internal low-speed RC has a typical frequency of 32 kHz. The RTC can be calibrated using an external 512 Hz output to compensate for any natural quartz deviation.

Two alarm registers are used to generate an alarm at a specific time and calendar fields can be independently masked for alarm comparison. To generate a periodic interrupt, a 16-bit programmable binary auto-reload downcounter with programmable resolution is available and allows automatic wakeup and periodic alarms from every 120  $\mu$ s to every 36 hours.

A 20-bit prescaler is used for the time base clock. It is by default configured to generate a time base of 1 second from a clock at 32.768 kHz.

The 4-Kbyte backup SRAM is an EEPROM-like area. It can be used to store data which need to be retained in VBAT and standby mode. This memory area is disabled to minimize power consumption (see [Section 2.2.18: Low-power modes](#)). It can be enabled by software.

The backup registers are 32-bit registers used to store 80 bytes of user application data when  $V_{DD}$  power is not present. Backup registers are not reset by a system, a power reset, or when the device wakes up from the Standby mode (see [Section 2.2.18: Low-power modes](#)).

Like backup SRAM, the RTC and backup registers are supplied through a switch that is powered either from the  $V_{DD}$  supply when present or the  $V_{BAT}$  pin.

## 2.2.18 Low-power modes

The STM32F21x family supports three low-power modes to achieve the best compromise between low power consumption, short startup time and available wakeup sources:

- **Sleep mode**

In Sleep mode, only the CPU is stopped. All peripherals continue to operate and can wake up the CPU when an interrupt/event occurs.

- **Stop mode**

The Stop mode achieves the lowest power consumption while retaining the contents of SRAM and registers. All clocks in the 1.2 V domain are stopped, the PLL, the HSI RC and the HSE crystal oscillators are disabled. The voltage regulator can also be put either in normal or in low-power mode.

The device can be woken up from the Stop mode by any of the EXTI line. The EXTI line source can be one of the 16 external lines, the PVD output, the RTC alarm / wakeup / tamper / time stamp events, the USB OTG FS/HS wakeup or the Ethernet wakeup.

- **Standby mode**

The Standby mode is used to achieve the lowest power consumption. The internal voltage regulator is switched off so that the entire 1.2 V domain is powered off. The PLL, the HSI RC and the HSE crystal oscillators are also switched off. After entering Standby mode, the SRAM and register contents are lost except for registers in the backup domain and the backup SRAM when selected.

The device exits the Standby mode when an external reset (NRST pin), an IWDG reset, a rising edge on the WKUP pin, or an RTC alarm / wakeup / tamper /time stamp event occurs.

*Note:* The RTC, the IWDG, and the corresponding clock sources are not stopped when the device enters the Stop or Standby mode.

## 2.2.19 V<sub>BAT</sub> operation

The V<sub>BAT</sub> pin allows to power the device V<sub>BAT</sub> domain from an external battery or an external supercapacitor.

V<sub>BAT</sub> operation is activated when V<sub>DD</sub> is not present.

The V<sub>BAT</sub> pin supplies the RTC, the backup registers and the backup SRAM.

*Note:* When the microcontroller is supplied from V<sub>BAT</sub>, external interrupts and RTC alarm/events do not exit it from V<sub>BAT</sub> operation.



## 2.2.20 Timers and watchdogs

The STM32F215xx and STM32F217xx devices include two advanced-control timers, eight general-purpose timers, two basic timers and two watchdog timers.

All timer counters can be frozen in debug mode.

[Table 3](#) compares the features of the advanced-control, general-purpose and basic timers.

**Table 3. Timer feature comparison**

Timer type	Timer	Counter resolution	Counter type	Prescaler factor	DMA request generation	Capture/compare channels	Complementary output	Max interface clock	Max timer clock
Advanced-control	TIM1, TIM8	16-bit	Up, Down, Up/down	Any integer between 1 and 65536	Yes	4	Yes	60 MHz	120 MHz
General purpose	TIM2, TIM5	32-bit	Up, Down, Up/down	Any integer between 1 and 65536	Yes	4	No	30 MHz	60 MHz
	TIM3, TIM4	16-bit	Up, Down, Up/down	Any integer between 1 and 65536	Yes	4	No	30 MHz	60 MHz
Basic	TIM6, TIM7	16-bit	Up	Any integer between 1 and 65536	Yes	0	No	30 MHz	60 MHz
General purpose	TIM9	16-bit	Up	Any integer between 1 and 65536	No	2	No	60 MHz	120 MHz
	TIM10, TIM11	16-bit	Up	Any integer between 1 and 65536	No	1	No	60 MHz	120 MHz
	TIM12	16-bit	Up	Any integer between 1 and 65536	No	2	No	30 MHz	60 MHz
	TIM13, TIM14	16-bit	Up	Any integer between 1 and 65536	No	1	No	30 MHz	60 MHz

### Advanced-control timers (TIM1, TIM8)

The advanced-control timers (TIM1, TIM8) can be seen as three-phase PWM generators multiplexed on 6 channels. They have complementary PWM outputs with programmable inserted dead times. They can also be considered as complete general-purpose timers.

Their 4 independent channels can be used for:

- Input capture
- Output compare
- PWM generation (edge- or center-aligned modes)
- One-pulse mode output

If configured as standard 16-bit timers, they have the same features as the general-purpose TIMx timers. If configured as 16-bit PWM generators, they have full modulation capability (0-100%).

The TIM1 and TIM8 counters can be frozen in debug mode. Many of the advanced-control timer features are shared with those of the standard TIMx timers which have the same architecture. The advanced-control timer can therefore work together with the TIMx timers via the Timer Link feature for synchronization or event chaining.

### General-purpose timers (TIMx)

There are ten synchronizable general-purpose timers embedded in the STM32F21x devices (see [Table 3](#) for differences).

- **TIM2, TIM3, TIM4, TIM5**

The STM32F21x include 4 full-featured general-purpose timers. TIM2 and TIM5 are 32-bit timers, and TIM3 and TIM4 are 16-bit timers. The TIM2 and TIM5 timers are based on a 32-bit auto-reload up/downcounter and a 16-bit prescaler. The TIM3 and TIM4 timers are based on a 16-bit auto-reload up/downcounter and a 16-bit prescaler. They all feature 4 independent channels for input capture/output compare, PWM or one-pulse mode output. This gives up to 16 input capture/output compare/PWMs on the largest packages.

The TIM2, TIM3, TIM4, TIM5 general-purpose timers can work together, or with the other general-purpose timers and the advanced-control timers TIM1 and TIM8 via the Timer Link feature for synchronization or event chaining.

The counters of TIM2, TIM3, TIM4, TIM5 can be frozen in debug mode. Any of these general-purpose timers can be used to generate PWM outputs.

TIM2, TIM3, TIM4, TIM5 all have independent DMA request generation. They are capable of handling quadrature (incremental) encoder signals and the digital outputs from 1 to 4 hall-effect sensors.

- **TIM10, TIM11 and TIM9**

These timers are based on a 16-bit auto-reload upcounter and a 16-bit prescaler. TIM10 and TIM11 feature one independent channel, whereas TIM9 has two independent channels for input capture/output compare, PWM or one-pulse mode output. They can be synchronized with the TIM2, TIM3, TIM4, TIM5 full-featured general-purpose timers. They can also be used as simple time bases.

- **TIM12, TIM13 and TIM14**

These timers are based on a 16-bit auto-reload upcounter and a 16-bit prescaler. TIM13 and TIM14 feature one independent channel, whereas TIM12 has two independent channels for input capture/output compare, PWM or one-pulse mode output. They can be synchronized with the TIM2, TIM3, TIM4, TIM5 full-featured general-purpose timers.

They can also be used as simple time bases.

### Basic timers TIM6 and TIM7

These timers are mainly used for DAC trigger and waveform generation. They can also be used as a generic 16-bit time base.

### Independent watchdog

The independent watchdog is based on a 12-bit downcounter and 8-bit prescaler. It is clocked from an independent 32 kHz internal RC and as it operates independently from the

main clock, it can operate in Stop and Standby modes. It can be used either as a watchdog to reset the device when a problem occurs, or as a free-running timer for application timeout management. It is hardware- or software-configurable through the option bytes. The counter can be frozen in debug mode.

### Window watchdog

The window watchdog is based on a 7-bit downcounter that can be set as free-running. It can be used as a watchdog to reset the device when a problem occurs. It is clocked from the main clock. It has an early warning interrupt capability and the counter can be frozen in debug mode.

### SysTick timer

This timer is dedicated to real-time operating systems, but could also be used as a standard downcounter. It features:

- A 24-bit downcounter
- Autoreload capability
- Maskable system interrupt generation when the counter reaches 0
- Programmable clock source

## 2.2.21 Inter-integrated circuit interface (I<sup>2</sup>C)

Up to three I<sup>2</sup>C bus interfaces can operate in multimaster and slave modes. They can support the Standard- and Fast-modes. They support the 7/10-bit addressing mode and the 7-bit dual addressing mode (as slave). A hardware CRC generation/verification is embedded.

They can be served by DMA and they support SMBus 2.0/PMBus.

## 2.2.22 Universal synchronous/asynchronous receiver transmitters (UARTs/USARTs)

The STM32F215xx and STM32F217xx embed four universal synchronous/asynchronous receiver transmitters (USART1, USART2, USART3 and USART6) and two universal asynchronous receiver transmitters (UART4 and UART5).

These six interfaces provide asynchronous communication, IrDA SIR ENDEC support, multiprocessor communication mode, single-wire half-duplex communication mode and have LIN Master/Slave capability. The USART1 and USART6 interfaces are able to communicate at speeds of up to 7.5 Mbit/s. The other available interfaces communicate at up to 3.75 Mbit/s.

USART1, USART2, USART3 and USART6 also provide hardware management of the CTS and RTS signals, Smart Card mode (ISO 7816 compliant) and SPI-like communication capability. All interfaces can be served by the DMA controller.

Table 4. USART feature comparison

USART name	Standard features	Modem (RTS/CTS)	LIN	SPI master	IrDA	Smartcard (ISO 7816)	Max. baud rate in Mbit/s (oversampling by 16)	Max. baud rate in Mbit/s (oversampling by 8)	APB mapping
USART1	X	X	X	X	X	X	1.87	7.5	APB2 (max. 60 MHz)
USART2	X	X	X	X	X	X	1.87	3.75	APB1 (max. 30 MHz)
USART3	X	X	X	X	X	X	1.87	3.75	APB1 (max. 30 MHz)
UART4	X	-	X	-	X	-	1.87	3.75	APB1 (max. 30 MHz)
UART5	X	-	X	-	X	-	3.75	3.75	APB1 (max. 30 MHz)
USART6	X	X	X	X	X	X	3.75	7.5	APB2 (max. 60 MHz)

### 2.2.23 Serial peripheral interface (SPI)

The STM32F21x feature up to three SPIs in slave and master modes in full-duplex and simplex communication modes. SPI1 can communicate at up to 30 Mbits/s, while SPI2 and SPI3 can communicate at up to 15 Mbit/s. The 3-bit prescaler gives 8 master mode frequencies and the frame is configurable to 8 bits or 16 bits. The hardware CRC generation/verification supports basic SD Card/MMC modes. All SPIs can be served by the DMA controller.

The SPI interface can be configured to operate in TI mode for communications in master mode and slave mode.

### 2.2.24 Inter-integrated sound (I<sup>2</sup>S)

Two standard I<sup>2</sup>S interfaces (multiplexed with SPI2 and SPI3) are available. They can operate in master or slave mode, in simplex communication modes, and can be configured to operate with a 16-/32-bit resolution as input or output channels. Audio sampling frequencies from 8 kHz up to 192 kHz are supported. When either or both of the I<sup>2</sup>S interfaces is/are configured in master mode, the master clock can be output to the external DAC/CODEC at 256 times the sampling frequency.

All I2Sx interfaces can be served by the DMA controller.

### 2.2.25 SDIO

An SD/SDIO/MMC host interface is available, that supports MultiMediaCard System Specification Version 4.2 in three different databus modes: 1-bit (default), 4-bit and 8-bit. The interface allows data transfer at up to 48 MHz in 8-bit mode, and is compliant with the SD Memory Card Specification Version 2.0.

The SDIO Card Specification Version 2.0 is also supported with two different databus modes: 1-bit (default) and 4-bit.

The current version supports only one SD/SDIO/MMC4.2 card at any one time and a stack of MMC4.1 or previous.

In addition to SD/SDIO/MMC, this interface is fully compliant with the CE-ATA digital protocol Rev1.1.

### 2.2.26 Ethernet MAC interface with dedicated DMA and IEEE 1588 support

Peripheral available only on the STM32F217xx devices.

The STM32F217xx devices provide an IEEE-802.3-2002-compliant media access controller (MAC) for ethernet LAN communications through an industry-standard medium-independent interface (MII) or a reduced medium-independent interface (RMII). The STM32F217xx requires an external physical interface device (PHY) to connect to the physical LAN bus (twisted-pair, fiber, etc.). the PHY is connected to the STM32F217xx MII port using 17 signals for MII or 9 signals for RMII, and can be clocked using the 25 MHz (MII) or 50 MHz (RMII) output from the STM32F217xx.

The STM32F217xx includes the following features:

- Supports 10 and 100 Mbit/s rates
- Dedicated DMA controller allowing high-speed transfers between the dedicated SRAM and the descriptors (see the STM32F20x and STM32F21x reference manual for details)
- Tagged MAC frame support (VLAN support)
- Half-duplex (CSMA/CD) and full-duplex operation
- MAC control sublayer (control frames) support
- 32-bit CRC generation and removal
- Several address filtering modes for physical and multicast address (multicast and group addresses)
- 32-bit status code for each transmitted or received frame
- Internal FIFOs to buffer transmit and receive frames. The transmit FIFO and the receive FIFO are both 2 Kbytes, that is 4 Kbytes in total
- Supports hardware PTP (precision time protocol) in accordance with IEEE 1588 2008 (PTP V2) with the time stamp comparator connected to the TIM2 input
- Triggers interrupt when system time becomes greater than target time

### 2.2.27 Controller area network (CAN)

The two CANs are compliant with the 2.0A and B (active) specifications with a bitrate up to 1 Mbit/s. They can receive and transmit standard frames with 11-bit identifiers as well as extended frames with 29-bit identifiers. Each CAN has three transmit mailboxes, two receive FIFOs with 3 stages and 28 shared scalable filter banks (all of them can be used even if one CAN is used). The 256 bytes of SRAM which are allocated for each CAN are not shared with any other peripheral.

### 2.2.28 Universal serial bus on-the-go full-speed (OTG\_FS)

The STM32F215xx and STM32F217xx embed an USB OTG full-speed device/host/OTG peripheral with integrated transceivers. The USB OTG FS peripheral is compliant with the USB 2.0 specification and with the OTG 1.0 specification. It has software-configurable endpoint setting and supports suspend/resume. The USB OTG full-speed controller requires a dedicated 48 MHz clock that is generated by a PLL connected to the HSE oscillator. The major features are:

- Combined Rx and Tx FIFO size of 320 × 35 bits with dynamic FIFO sizing
- Supports the session request protocol (SRP) and host negotiation protocol (HNP)
- 4 bidirectional endpoints
- 8 host channels with periodic OUT support
- HNP/SNP/IP inside (no need for any external resistor)
- For OTG/Host modes, a power switch is needed in case bus-powered devices are connected
- Internal FS OTG PHY support

### 2.2.29 Universal serial bus on-the-go high-speed (OTG\_HS)

The STM32F215xx and STM32F217xx devices embed a USB OTG high-speed (up to 480 Mb/s) device/host/OTG peripheral. The USB OTG HS supports both full-speed and high-speed operations. It integrates the transceivers for full-speed operation (12 MB/s) and features a UTMI low-pin interface (ULPI) for high-speed operation (480 MB/s). When using the USB OTG HS in HS mode, an external PHY device connected to the ULPI is required.

The USB OTG HS peripheral is compliant with the USB 2.0 specification and with the OTG 1.0 specification. It has software-configurable endpoint setting and supports

suspend/resume. The USB OTG full-speed controller requires a dedicated 48 MHz clock that is generated by a PLL connected to the HSE oscillator. The major features are:

- Combined Rx and Tx FIFO size of 1024× 35 bits with dynamic FIFO sizing
- Supports the session request protocol (SRP) and host negotiation protocol (HNP)
- 6 bidirectional endpoints
- 12 host channels with periodic OUT support
- Internal FS OTG PHY support
- External FS OTG PHY support through an I<sup>2</sup>C connection
- External HS or HS OTG operation supporting ULPI in SDR mode. The OTG PHY is connected to the microcontroller ULPI port through 12 signals. It can be clocked using the 60 MHz output.
- Internal USB DMA
- HNP/SNP/IP inside (no need for any external resistor)
- For OTG/Host modes, a power switch is needed in case bus-powered devices are connected

### 2.2.30 Audio PLL (PLLI2S)

The devices feature an additional dedicated PLL for audio I<sup>2</sup>S application. It allows to achieve error-free I<sup>2</sup>S sampling clock accuracy without compromising on the CPU performance, while using USB peripherals.

The PLLI2S configuration can be modified to manage an I<sup>2</sup>S sample rate change without disabling the main PLL (PLL) used for CPU, USB and Ethernet interfaces.

The audio PLL can be programmed with very low error to obtain sampling rates ranging from 8 kHz to 192 kHz.

In addition to the audio PLL, a master clock input pin can be used to synchronize the I2S flow with an external PLL (or Codec output).

### 2.2.31 Digital camera interface (DCMI)

The camera interface is *not* available in STM32F215xx devices.

STM32F217xx products embed a camera interface that can connect with camera modules and CMOS sensors through an 8-bit to 14-bit parallel interface, to receive video data. The camera interface can sustain up to 27 Mbyte/s at 27 MHz or 48 Mbyte/s at 48 MHz. It features:

- Programmable polarity for the input pixel clock and synchronization signals
- Parallel data communication can be 8-, 10-, 12- or 14-bit
- Supports 8-bit progressive video monochrome or raw Bayer format, YCbCr 4:2:2 progressive video, RGB 565 progressive video or compressed data (like JPEG)
- Supports continuous mode or snapshot (a single frame) mode
- Capability to automatically crop the image

### 2.2.32 Cryptographic acceleration

The STM32F215xx and STM32F217xx devices embed a cryptographic accelerator. This cryptographic accelerator provides a set of hardware acceleration for the advanced cryptographic algorithms usually needed to provide confidentiality, authentication, data integrity and non repudiation when exchanging messages with a peer.

- These algorithms consists of:
  - Encryption/Decryption
    - DES/TDES (data encryption standard/triple data encryption standard): ECB (electronic codebook) and CBC (cipher block chaining) chaining algorithms, 64-, 128- or 192-bit key
    - AES (advanced encryption standard): ECB, CBC and CTR (counter mode) chaining algorithms, 128, 192 or 256-bit key
  - Universal hash
    - SHA-1 (secure hash algorithm)
    - MD5
- It also provides a true random number generator that deliver 32-bit random numbers produced by an integrated analog circuit.

### 2.2.33 True random number generator (RNG)

All STM32F2xxx products embed a true RNG that delivers 32-bit random numbers produced by an integrated analog circuit.



### 2.2.34 GPIOs (general-purpose inputs/outputs)

Each of the GPIO pins can be configured by software as output (push-pull or open-drain, with or without pull-up or pull-down), as input (floating, with or without pull-up or pull-down) or as peripheral alternate function. Most of the GPIO pins are shared with digital or analog alternate functions. All GPIOs are high-current-capable and have speed selection to better manage internal noise, power consumption and electromagnetic emission.

The I/O alternate function configuration can be locked if needed by following a specific sequence in order to avoid spurious writing to the I/Os registers.

To provide fast I/O handling, the GPIOs are on the fast AHB1 bus with a clock up to 120 MHz that leads to a maximum I/O toggling speed of 60 MHz.

### 2.2.35 ADCs (analog-to-digital converters)

Three 12-bit analog-to-digital converters are embedded and each ADC shares up to 16 external channels, performing conversions in the single-shot or scan mode. In scan mode, automatic conversion is performed on a selected group of analog inputs.

Additional logic functions embedded in the ADC interface allow:

- Simultaneous sample and hold
- Interleaved sample and hold

The ADC can be served by the DMA controller. An analog watchdog feature allows very precise monitoring of the converted voltage of one, some or all selected channels. An interrupt is generated when the converted voltage is outside the programmed thresholds.

The events generated by the timers TIM1, TIM2, TIM3, TIM4, TIM5 and TIM8 can be internally connected to the ADC start trigger and injection trigger, respectively, to allow the application to synchronize A/D conversion and timers.

### 2.2.36 DAC (digital-to-analog converter)

The two 12-bit buffered DAC channels can be used to convert two digital signals into two analog voltage signal outputs. The design structure is composed of integrated resistor strings and an amplifier in inverting configuration.

This dual digital Interface supports the following features:

- two DAC converters: one for each output channel
- 8-bit or 12-bit monotonic output
- left or right data alignment in 12-bit mode
- synchronized update capability
- noise-wave generation
- triangular-wave generation
- dual DAC channel independent or simultaneous conversions
- DMA capability for each channel
- external triggers for conversion
- input voltage reference  $V_{REF+}$

Eight DAC trigger inputs are used in the device. The DAC channels are triggered through the timer update outputs that are also connected to different DMA streams.

### 2.2.37 Temperature sensor

The temperature sensor has to generate a voltage that varies linearly with temperature. The conversion range is between 1.8 and 3.6 V. The temperature sensor is internally connected to the ADC1\_IN16 input channel which is used to convert the sensor output voltage into a digital value.

As the offset of the temperature sensor varies from chip to chip due to process variation, the internal temperature sensor is mainly suitable for applications that detect temperature changes instead of absolute temperatures. If an accurate temperature reading is needed, then an external temperature sensor part should be used.

### 2.2.38 Serial wire JTAG debug port (SWJ-DP)

The ARM SWJ-DP interface is embedded, and is a combined JTAG and serial wire debug port that enables either a serial wire debug or a JTAG probe to be connected to the target. The JTAG TMS and TCK pins are shared with SWDIO and SWCLK, respectively, and a specific sequence on the TMS pin is used to switch between JTAG-DP and SW-DP.

### 2.2.39 Embedded Trace Macrocell™

The ARM Embedded Trace Macrocell provides a greater visibility of the instruction and data flow inside the CPU core by streaming compressed data at a very high rate from the STM32F21x through a small number of ETM pins to an external hardware trace port analyzer (TPA) device. The TPA is connected to a host computer using USB, Ethernet, or any other high-speed channel. Real-time instruction and data flow activity can be recorded and then formatted for display on the host computer that runs the debugger software. TPA hardware is commercially available from common development tool vendors.

The Embedded Trace Macrocell operates with third party debugger software tools.

### 3 Pinouts and pin description

Figure 9. STM32F21x LQFP64 pinout

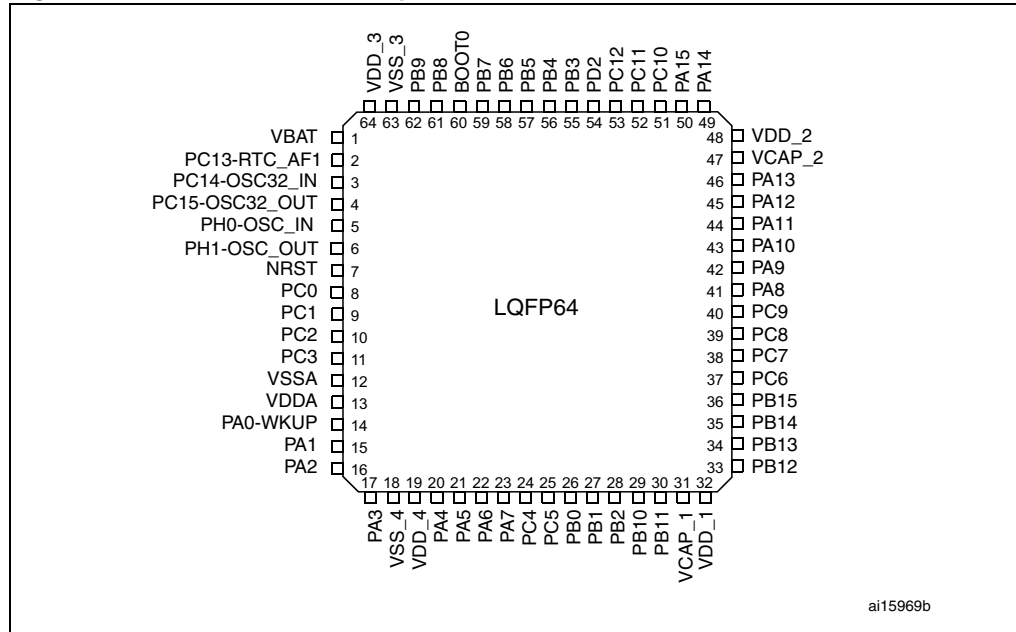
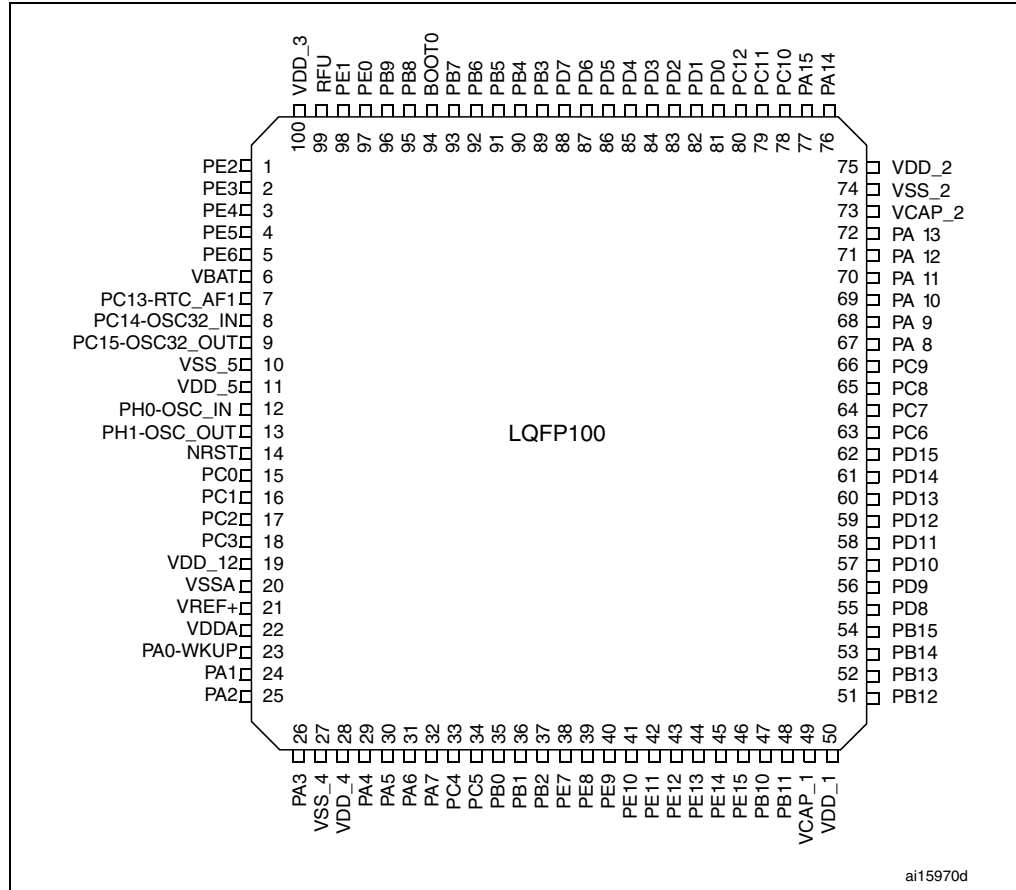
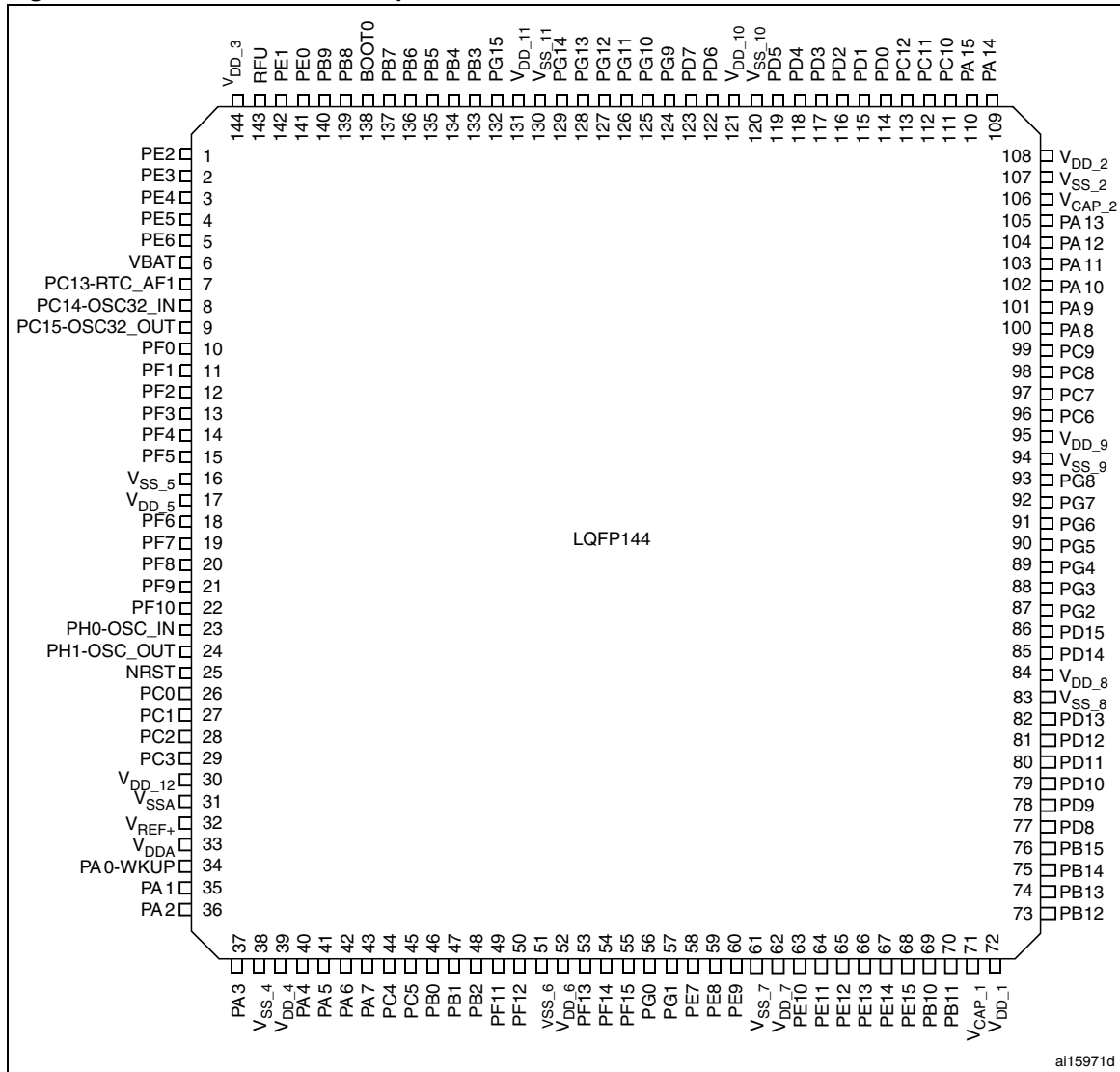


Figure 10. STM32F21x LQFP100 pinout



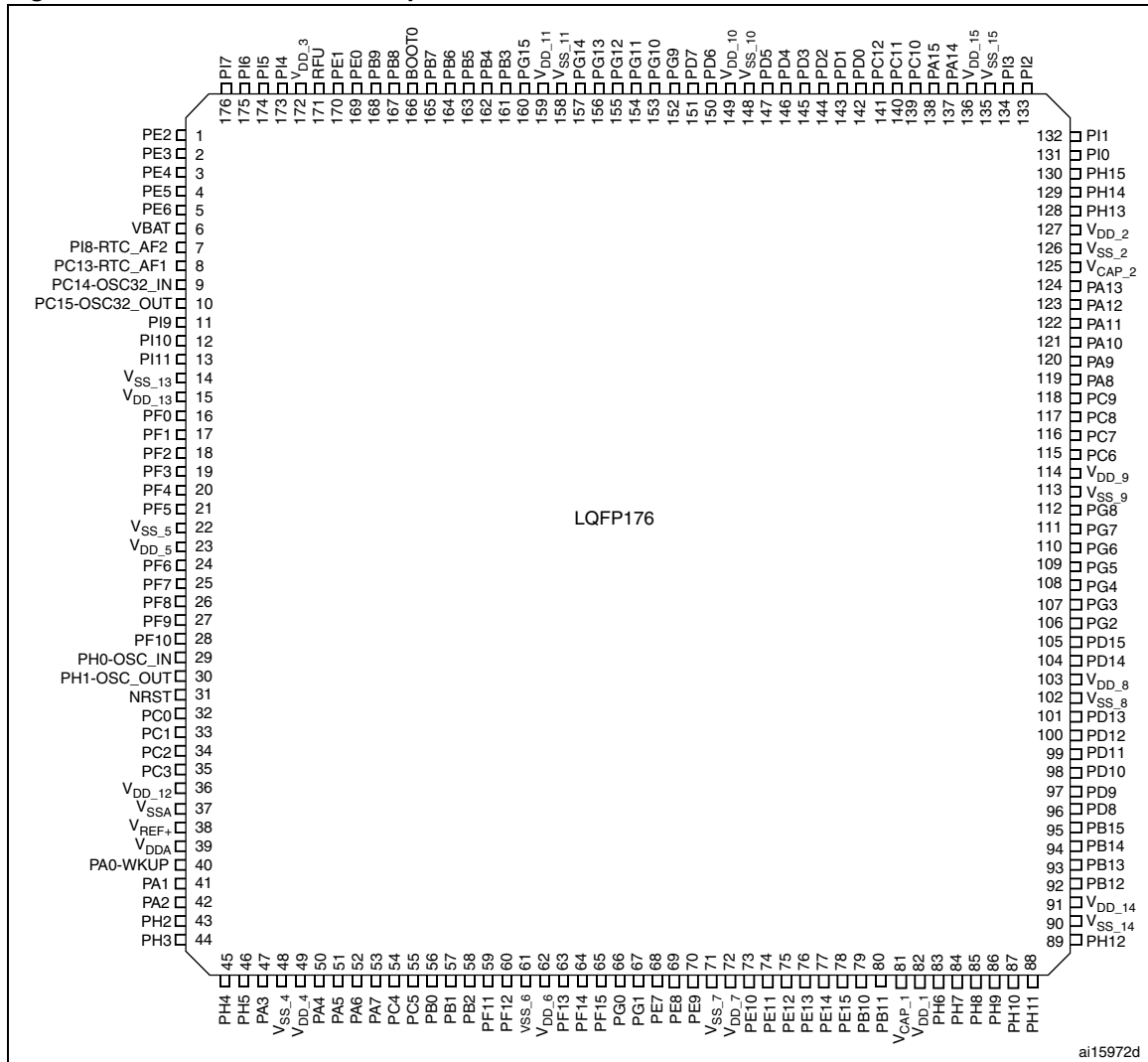
1. RFU means "reserved for future use". This pin can be tied to V<sub>DD</sub>, V<sub>SS</sub> or left unconnected.

Figure 11. STM32F21x LQFP144 pinout



1. RFU means “reserved for future use”. This pin can be tied to  $V_{DD}$ ,  $V_{SS}$  or left unconnected.

Figure 12. STM32F21x LQFP176 pinout



1. RFU means "reserved for future use". This pin can be tied to V<sub>DD</sub>, V<sub>SS</sub> or left unconnected.

Figure 13. STM32F21x UFBGA176 ballout

	1	2	3	4	5	6	7	8	9	10	11	12	13	14	15																									
A	PE3	PE2	PE1	PE0	PB8	PB5	PG14	PG13	PB4	PB3	PD7	PC12	PA15	PA14	PA13																									
B	PE4	PE5	PE6	PB9	PB7	PB6	PG15	PG12	PG11	PG10	PD6	PD0	PC11	PC10	PA12																									
C	VBAT	PI7	PI6	PI5	VDD_3	RFU	VDD_11	VDD_10	VDD_15	PG9	PD5	PD1	PI3	PI2	PA11																									
D	PC13-TAMP1	PI8-TAMP2	PI9	PI4	VSS	BOOT0	VSS_11	VSS_10	VSS_15	PD4	PD3	PD2	PH15	PH1	PA10																									
E	PC14-OSC32_IN	PF0	PI10	PI11	<table border="1"> <tr><td>VSS</td><td>VSS</td><td>VSS</td><td>VSS</td><td>VSS</td></tr> <tr><td>VSS</td><td>VSS</td><td>VSS</td><td>VSS</td><td>VSS</td></tr> <tr><td>VSS</td><td>VSS</td><td>VSS</td><td>VSS</td><td>VSS</td></tr> <tr><td>VSS</td><td>VSS</td><td>VSS</td><td>VSS</td><td>VSS</td></tr> <tr><td>VSS</td><td>VSS</td><td>VSS</td><td>VSS</td><td>VSS</td></tr> </table>							VSS	VSS	VSS	VSS	VSS	VSS	VSS	VSS	VSS	VSS	VSS	VSS	VSS	VSS	VSS	VSS	VSS	VSS	VSS	VSS	VSS	VSS	VSS	VSS	VSS	PH13	PH14	PH0	PA9
VSS	VSS	VSS	VSS	VSS																																				
VSS	VSS	VSS	VSS	VSS																																				
VSS	VSS	VSS	VSS	VSS																																				
VSS	VSS	VSS	VSS	VSS																																				
VSS	VSS	VSS	VSS	VSS																																				
F	PC15-OSC32_OUT	VSS_13	VDD_13	PH2	VSS_2	VCAP2	PC9	PA8																																
G	PH0-OSC_IN	VSS_5	VDD_5	PH3	VSS_9	VDD_2	PC8	PC7																																
H	PH1-OSC_OUT	PF2	PF1	PH4	VSS_14	VDD_9	PG8	PC6																																
J	NRST	PF3	PF4	PH5	VDD_14	VDD_8	PG7	PG6																																
K	PF7	PF6	PF5	VDD_4	PH12	PG5	PG4	PG3																																
L	PF10	PF9	PF8	REGOFF	PH11	PH10	PD15	PG2																																
M	VSSA	PC0	PC1	PC2	PC3	PB2	PG1	VSS_6	VSS_7	VCAP1	PH6	PH8	PH9	PD14	PD13																									
N	VREF-	PA1	PA0-WKUP	PA4	PC4	PF13	PG0	VDD_6	VDD_7	VDD_1	PE13	PH7	PD12	PD11	PD10																									
P	VREF+	PA2	PA6	PA5	PC5	PF12	PF15	PE8	PE9	PE11	PE14	PB12	PB13	PD9	PD8																									
R	VDDA	PA3	PA7	PB1	PB0	PF11	PF14	PE7	PE10	PE12	PE15	PB10	PB11	PB14	PB15																									

ai17293b

1. RFU means “reserved for future use”. This pin can be tied to V<sub>DD</sub>, V<sub>SS</sub> or left unconnected.
2. Top view.

Table 5. STM32F21x pin and ball definitions

Pins					Pin name	Type <sup>(1)</sup>	I/O Level <sup>(2)</sup>	Main function <sup>(3)</sup> (after reset)	Alternate functions	Other functions
LQFP64	LQFP100	LQFP144	LQFP176	UFBGA176						
-	1	1	1	A2	PE2	I/O	FT	PE2	TRACECLK/ FSMC_A23 / ETH_MII_TXD3 / EVENTOUT	
-	2	2	2	A1	PE3	I/O	FT	PE3	TRACED0/FSMC_A19/ EVENTOUT	
-	3	3	3	B1	PE4	I/O	FT	PE4	TRACED1/FSMC_A20 / DCMI_D4/ EVENTOUT	
-	4	4	4	B2	PE5	I/O	FT	PE5	TRACED2 / FSMC_A21 / TIM9_CH1 / DCMI_D6/ EVENTOUT	
-	5	5	5	B3	PE6	I/O	FT	PE6	TRACED3 / FSMC_A22 / TIM9_CH2 / DCMI_D7/ EVENTOUT	
1	6	6	6	C1	V <sub>BAT</sub>	S		V <sub>BAT</sub>		

Table 5. STM32F21x pin and ball definitions (continued)

Pins					Pin name	Type <sup>(1)</sup>	I / O Level <sup>(2)</sup>	Main function <sup>(3)</sup> (after reset)	Alternate functions	Other functions
LQFP64	LQFP100	LQFP144	LQFP176	UFBGA176						
-	-	-	7	D2	PI8 <sup>(4)</sup>	I/O	FT	PI8 <sup>(5)</sup>	EVENTOUT	RTC_AF2
2	7	7	8	D1	PC13 <sup>(4)</sup>	I/O	FT	PC13 <sup>(5)</sup>	EVENTOUT	RTC_AF1
3	8	8	9	E1	PC14 <sup>(4)</sup> -OSC32_IN <sup>(6)</sup>	I/O	FT	PC14 <sup>(5)</sup>	EVENTOUT	OSC32_IN
4	9	9	10	F1	PC15 <sup>(4)</sup> - OSC32_OUT <sup>(6)</sup>	I/O	FT	PC15 <sup>(5)</sup>	EVENTOUT	OSC32_OUT
-	-	-	11	D3	PI9	I/O	FT	PI9	CAN1_RX / EVENTOUT	
-	-	-	12	E3	PI10	I/O	FT	PI10	ETH_MII_RX_ER/ EVENTOUT	
-	-	-	13	E4	PI11	I/O	FT	PI11	OTG_HS_ULPI_DIR/ EVENTOUT	
-	-	-	14	F2	V <sub>SS_13</sub>	S		V <sub>SS_13</sub>		
-	-	-	15	F3	V <sub>DD_13</sub>	S		V <sub>DD_13</sub>		
-	-	10	16	E2	PF0	I/O	FT	PF0	FSMC_A0 / I2C2_SDA/ EVENTOUT	
-	-	11	17	H3	PF1	I/O	FT	PF1	FSMC_A1 / I2C2_SCL/ EVENTOUT	
-	-	12	18	H2	PF2	I/O	FT	PF2	FSMC_A2 / I2C2_SMBA/ EVENTOUT	
-	-	13	19	J2	PF3 <sup>(6)</sup>	I/O	FT	PF3	FSMC_A3/ EVENTOUT	ADC3_IN9
-	-	14	20	J3	PF4 <sup>(6)</sup>	I/O	FT	PF4	FSMC_A4/ EVENTOUT	ADC3_IN14
-	-	15	21	K3	PF5 <sup>(6)</sup>	I/O	FT	PF5	FSMC_A5/ EVENTOUT	ADC3_IN15
-	10	16	22	G2	V <sub>SS_5</sub>	S		V <sub>SS_5</sub>		
-	11	17	23	G3	V <sub>DD_5</sub>	S		V <sub>DD_5</sub>		
-	-	18	24	K2	PF6 <sup>(6)</sup>	I/O	FT	PF6	TIM10_CH1 / FSMC_NIORD/ EVENTOUT	ADC3_IN4
-	-	19	25	K1	PF7 <sup>(6)</sup>	I/O	FT	PF7	TIM11_CH1/FSMC_NREG/ EVENTOUT	ADC3_IN5
-	-	20	26	L3	PF8 <sup>(6)</sup>	I/O	FT	PF8	TIM13_CH1 / FSMC_NIOWR/ EVENTOUT	ADC3_IN6
-	-	21	27	L2	PF9 <sup>(6)</sup>	I/O	FT	PF9	TIM14_CH1 / FSMC_CD/ EVENTOUT	ADC3_IN7
-	-	22	28	L1	PF10 <sup>(6)</sup>	I/O	FT	PF10	FSMC_INTR/ EVENTOUT	ADC3_IN8
5	12	23	29	G1	PH0 <sup>(6)</sup> -OSC_IN	I/O	FT	PH0	EVENTOUT	OSC_IN
6	13	24	30	H1	PH1 <sup>(6)</sup> -OSC_OUT	I/O	FT	PH1	EVENTOUT	OSC_OUT
7	14	25	31	J1	NRST	I/O		NRST		



Table 5. STM32F21x pin and ball definitions (continued)

Pins					Pin name	Type <sup>(1)</sup>	I/O Level <sup>(2)</sup>	Main function <sup>(3)</sup> (after reset)	Alternate functions	Other functions
LQFP64	LQFP100	LQFP144	LQFP176	UFBGA176						
8	15	26	32	M2	PC0 <sup>(6)</sup>	I/O	FT	PC0	OTG_HS_ULPI_STP/ EVENTOUT	ADC123_ IN10
9	16	27	33	M3	PC1 <sup>(6)</sup>	I/O	FT	PC1	ETH_MDC/ EVENTOUT	ADC123_ IN11
10	17	28	34	M4	PC2 <sup>(6)</sup>	I/O	FT	PC2	SPI2_MISO / OTG_HS_ULPI_DIR / ETH_MII_TXD2/ EVENTOUT	ADC123_ IN12
11	18	29	35	M5	PC3 <sup>(6)</sup>	I/O	FT	PC3	SPI2_MOSI / I2S2_SD / OTG_HS_ULPI_NXT / ETH_MII_TX_CLK/ EVENTOUT	ADC123_ IN13
-	19	30	36	-	V <sub>DD_12</sub>	S		V <sub>DD_12</sub>		
12	20	31	37	M1	V <sub>SSA</sub>	S		V <sub>SSA</sub>		
-	-	-	-	N1	V <sub>REF-</sub>	S		V <sub>REF-</sub>		
-	21	32	38	P1	V <sub>REF+</sub>	S		V <sub>REF+</sub>		
13	22	33	39	R1	V <sub>DDA</sub>	S		V <sub>DDA</sub>		
14	23	34	40	N3	PA0 <sup>(7)</sup> -WKUP <sup>(6)</sup>	I/O	FT	PA0-WKUP	USART2_CTS/ UART4_TX/ ETH_MII_CRS / TIM2_CH1_ETR/ TIM5_CH1 / TIM8_ETR/ EVENTOUT	ADC123_IN0/ WKUP
15	24	35	41	N2	PA1 <sup>(6)</sup>	I/O	FT	PA1	USART2_RTS / UART4_RX/ ETH_RMII_REF_CLK / ETH_MII_RX_CLK / TIM5_CH2 / TIM2_CH2/ EVENTOUT	ADC123_IN1
16	25	36	42	P2	PA2 <sup>(6)</sup>	I/O	FT	PA2	USART2_TX/TIM5_CH3 / TIM9_CH1 / TIM2_CH3 / ETH_MDIO/ EVENTOUT	ADC123_IN2
-	-	-	43	F4	PH2	I/O	FT	PH2	ETH_MII_CRS/ EVENTOUT	
-	-	-	44	G4	PH3	I/O	FT	PH3	ETH_MII_COL/ EVENTOUT	
-	-	-	45	H4	PH4	I/O	FT	PH4	I2C2_SCL / OTG_HS_ULPI_NXT/ EVENTOUT	
-	-	-	46	J4	PH5	I/O	FT	PH5	I2C2_SDA/ EVENTOUT	
17	26	37	47	R2	PA3 <sup>(6)</sup>	I/O	FT	PA3	USART2_RX/TIM5_CH4 / TIM9_CH2 / TIM2_CH4 / OTG_HS_ULPI_D0 / ETH_MII_COL/ EVENTOUT	ADC123_IN3

Table 5. STM32F21x pin and ball definitions (continued)

Pins					Pin name	Type <sup>(1)</sup>	I/O Level <sup>(2)</sup>	Main function <sup>(3)</sup> (after reset)	Alternate functions	Other functions
LQFP64	LQFP100	LQFP144	LQFP176	UFBGA176						
18	27	38	48	-	V <sub>SS_4</sub>	S		V <sub>SS_4</sub>		
				L4	REGOFF	I/O		REGOFF		
19	28	39	49	K4	V <sub>DD_4</sub>	S		V <sub>DD_4</sub>		
20	29	40	50	N4	PA4 <sup>(6)</sup>	I/O	TT	PA4	SPI1_NSS / SPI3_NSS / USART2_CK / DCMI_HSYNC / OTG_HS_SOF/ I2S3_WS/ EVENTOUT	ADC12_IN4 /DAC1_OUT
21	30	41	51	P4	PA5 <sup>(6)</sup>	I/O	TT	PA5	SPI1_SCK/ OTG_HS_ULPI_CK / TIM2_CH1_ETR/ TIM8_CHIN/ EVENTOUT	ADC12_IN5 /DAC2_OUT
22	31	42	52	P3	PA6 <sup>(6)</sup>	I/O	FT	PA6	SPI1_MISO / TIM8_BKIN/TIM13_CH1 / DCMI_PIXCLK / TIM3_CH1 / TIM1_BKIN/ EVENTOUT	ADC12_IN6
23	32	43	53	R3	PA7 <sup>(6)</sup>	I/O	FT	PA7	SPI1_MOSI/ TIM8_CH1N / TIM14_CH1 TIM3_CH2/ ETH_MII_RX_DV / TIM1_CH1N / RMII_CRS_DV/ EVENTOUT	ADC12_IN7
24	33	44	54	N5	PC4 <sup>(6)</sup>	I/O	FT	PC4	ETH_RMII_RX_D0 / ETH_MII_RX_D0/ EVENTOUT	ADC12_IN14
25	34	45	55	P5	PC5 <sup>(6)</sup>	I/O	FT	PC5	ETH_RMII_RX_D1 / ETH_MII_RX_D1 / EVENTOUT	ADC12_IN15
26	35	46	56	R5	PB0 <sup>(6)</sup>	I/O	FT	PB0	TIM3_CH3 / TIM8_CH2N/ OTG_HS_ULPI_D1/ ETH_MII_RXD2 / TIM1_CH2N/ EVENTOUT	ADC12_IN8
27	36	47	57	R4	PB1 <sup>(6)</sup>	I/O	FT	PB1	TIM3_CH4 / TIM8_CH3N/ OTG_HS_ULPI_D2/ ETH_MII_RXD3 / OTG_HS_INTN / TIM1_CH3N/ EVENTOUT	ADC12_IN9
28	37	48	58	M6	PB2	I/O	FT	PB2-BOOT1	EVENTOUT	
-	-	49	59	R6	PF11	I/O	FT	PF11	DCMI_12/ EVENTOUT	
-	-	50	60	P6	PF12	I/O	FT	PF12	FSMC_A6/ EVENTOUT	
-	-	51	61	M8	V <sub>SS_6</sub>	S		V <sub>SS_6</sub>		

Table 5. STM32F21x pin and ball definitions (continued)

Pins					Pin name	Type <sup>(1)</sup>	I / O Level <sup>(2)</sup>	Main function <sup>(3)</sup> (after reset)	Alternate functions	Other functions
LQFP64	LQFP100	LQFP144	LQFP176	UFBGA176						
-	-	52	62	N8	V <sub>DD_6</sub>	S		V <sub>DD_6</sub>		
-	-	53	63	N6	PF13	I/O	FT	PF13	FSMC_A7/ EVENTOUT	
-	-	54	64	R7	PF14	I/O	FT	PF14	FSMC_A8/ EVENTOUT	
-	-	55	65	P7	PF15	I/O	FT	PF15	FSMC_A9/ EVENTOUT	
-	-	56	66	N7	PG0	I/O	FT	PG0	FSMC_A10/ EVENTOUT	
-	-	57	67	M7	PG1	I/O	FT	PG1	FSMC_A11/ EVENTOUT	
-	38	58	68	R8	PE7	I/O	FT	PE7	FSMC_D4/TIM1_ETR/ EVENTOUT	
-	39	59	69	P8	PE8	I/O	FT	PE8	FSMC_D5/TIM1_CH1N/ EVENTOUT	
-	40	60	70	P9	PE9	I/O	FT	PE9	FSMC_D6/TIM1_CH1/ EVENTOUT	
-	-	61	71	M9	V <sub>SS_7</sub>	S		V <sub>SS_7</sub>		
-	-	62	72	N9	V <sub>DD_7</sub>	S		V <sub>DD_7</sub>		
-	41	63	73	R9	PE10	I/O	FT	PE10	FSMC_D7/TIM1_CH2N/ EVENTOUT	
-	42	64	74	P10	PE11	I/O	FT	PE11	FSMC_D8/TIM1_CH2/ EVENTOUT	
-	43	65	75	R10	PE12	I/O	FT	PE12	FSMC_D9/TIM1_CH3N/ EVENTOUT	
-	44	66	76	N11	PE13	I/O	FT	PE13	FSMC_D10/TIM1_CH3/ EVENTOUT	
-	45	67	77	P11	PE14	I/O	FT	PE14	FSMC_D11/TIM1_CH4/ EVENTOUT	
-	46	68	78	R11	PE15	I/O	FT	PE15	FSMC_D12/TIM1_BKIN/ EVENTOUT	
29	47	69	79	R12	PB10	I/O	FT	PB10	SPI2_SCK/ I2S2_SCK/ I2C2_SCL / USART3_TX / OTG_HS_ULPI_D3 / ETH_MII_RX_ER / OTG_HS_SCL / TIM2_CH3/ EVENTOUT	
30	48	70	80	R13	PB11	I/O	FT	PB11	I2C2_SDA/USART3_RX/ OTG_HS_ULPI_D4 / ETH_RMII_TX_EN/ ETH_MII_TX_EN / OTG_HS_SDA / TIM2_CH4/ EVENTOUT	
31	49	71	81	M10	V <sub>CAP_1</sub>	S		V <sub>CAP_1</sub>		

Table 5. STM32F21x pin and ball definitions (continued)

Pins					Pin name	Type <sup>(1)</sup>	I/O Level <sup>(2)</sup>	Main function <sup>(3)</sup> (after reset)	Alternate functions	Other functions
LQFP64	LQFP100	LQFP144	LQFP176	UFBGA176						
32	50	72	82	N10	V <sub>DD_1</sub>	S		V <sub>DD_1</sub>		
-	-	-	83	M11	PH6	I/O	FT	PH6	I2C2_SMBA / TIM12_CH1 / ETH_MII_RXD2/ EVENTOUT	
-	-	-	84	N12	PH7	I/O	FT	PH7	I2C3_SCL / ETH_MII_RXD3/ EVENTOUT	
-	-	-	85	M12	PH8	I/O	FT	PH8	I2C3_SDA / DCMI_HSYNC/ EVENTOUT	
-	-	-	86	M13	PH9	I/O	FT	PH9	I2C3_SMBA / TIM12_CH2/ DCMI_D0/ EVENTOUT	
-	-	-	87	L13	PH10	I/O	FT	PH10	TIM5_CH1_ETR / DCMI_D1/ EVENTOUT	
-	-	-	88	L12	PH11	I/O	FT	PH11	TIM5_CH2 / DCMI_D2/ EVENTOUT	
-	-	-	89	K12	PH12	I/O	FT	PH12	TIM5_CH3 / DCMI_D3/ EVENTOUT	
-	-	-	90	H12	V <sub>SS_14</sub>	S		V <sub>SS_14</sub>		
-	-	-	91	J12	V <sub>DD_14</sub>	S		V <sub>DD_14</sub>		
33	51	73	92	P12	PB12	I/O	FT	PB12	SPI2_NSS/I2S2_WS/ I2C2_SMBA/ USART3_CK/ TIM1_BKIN / CAN2_RX / OTG_HS_ULPI_D5/ ETH_RMII_TXD0 / ETH_MII_TXD0/ OTG_HS_ID/ EVENTOUT	
34	52	74	93	P13	PB13	I/O	FT	PB13	SPI2_SCK / I2S2_SCK / USART3_CTS/ TIM1_CH1N /CAN2_TX / OTG_HS_ULPI_D6 / ETH_RMII_TXD1 / ETH_MII_TXD1/ EVENTOUT	OTG_HS_VBUS
35	53	75	94	R14	PB14	I/O	FT	PB14	SPI2_MISO/ TIM1_CH2N / TIM12_CH1 / OTG_HS_DM USART3_RTS/TIM8_CH2N/ EVENTOUT	
36	54	76	95	R15	PB15	I/O	FT	PB15	SPI2_MOSI / I2S2_SD / TIM1_CH3N / TIM8_CH3N / TIM12_CH2 / OTG_HS_DP / RTC_50Hz/ EVENTOUT	

Table 5. STM32F21x pin and ball definitions (continued)

Pins					Pin name	Type <sup>(1)</sup>		Main function <sup>(3)</sup> (after reset)	Alternate functions	Other functions
LQFP64	LQFP100	LQFP144	LQFP176	UFBGA176		I/O	Level <sup>(2)</sup>			
-	55	77	96	P15	PD8	I/O	FT	PD8	FSMC_D13 / USART3_TX / EVENTOUT	
-	56	78	97	P14	PD9	I/O	FT	PD9	FSMC_D14 / USART3_RX / EVENTOUT	
-	57	79	98	N15	PD10	I/O	FT	PD10	FSMC_D15 / USART3_CK / EVENTOUT	
-	58	80	99	N14	PD11	I/O	FT	PD11	FSMC_A16/USART3_CTS / EVENTOUT	
-	59	81	100	N13	PD12	I/O	FT	PD12	FSMC_A17/TIM4_CH1 / USART3_RTS / EVENTOUT	
-	60	82	101	M15	PD13	I/O	FT	PD13	FSMC_A18/TIM4_CH2 / EVENTOUT	
-	-	83	102	-	V <sub>SS_8</sub>	S		V <sub>SS_8</sub>		
-	-	84	103	J13	V <sub>DD_8</sub>	S		V <sub>DD_8</sub>		
-	61	85	104	M14	PD14	I/O	FT	PD14	FSMC_D0/TIM4_CH3 / EVENTOUT	
-	62	86	105	L14	PD15	I/O	FT	PD15	FSMC_D1/TIM4_CH4 / EVENTOUT	
-	-	87	106	L15	PG2	I/O	FT	PG2	FSMC_A12 / EVENTOUT	
-	-	88	107	K15	PG3	I/O	FT	PG3	FSMC_A13 / EVENTOUT	
-	-	89	108	K14	PG4	I/O	FT	PG4	FSMC_A14 / EVENTOUT	
-	-	90	109	K13	PG5	I/O	FT	PG5	FSMC_A15 / EVENTOUT	
-	-	91	110	J15	PG6	I/O	FT	PG6	FSMC_INT2 / EVENTOUT	
-	-	92	111	J14	PG7	I/O	FT	PG7	FSMC_INT3 / USART6_CK / EVENTOUT	
-	-	93	112	H14	PG8	I/O	FT	PG8	USART6_RTS / ETH_PPS_OUT / EVENTOUT	
-	-	94	113	G12	V <sub>SS_9</sub>	S		V <sub>SS_9</sub>		
-	-	95	114	H13	V <sub>DD_9</sub>	S		V <sub>DD_9</sub>		
37	63	96	115	H15	PC6	I/O	FT	PC6	I2S2_MCK / TIM8_CH1/SDIO_D6 / USART6_TX / DCMI_D0/TIM3_CH1 / EVENTOUT	

Table 5. STM32F21x pin and ball definitions (continued)

Pins					Pin name	Type <sup>(1)</sup>	I / O Level <sup>(2)</sup>	Main function <sup>(3)</sup> (after reset)	Alternate functions	Other functions
LQFP64	LQFP100	LQFP144	LQFP176	UFBGA176						
38	64	97	116	G15	PC7	I/O	FT	PC7	I2S3_MCK / TIM8_CH2/SDIO_D7 / USART6_RX / DCMI_D1/TIM3_CH2/ EVENTOUT	
39	65	98	117	G14	PC8	I/O	FT	PC8	TIM8_CH3/SDIO_D0 /TIM3_CH3/ USART6_CK / DCMI_D2/ EVENTOUT	
40	66	99	118	F14	PC9	I/O	FT	PC9	I2S2_CKIN/ I2S3_CKIN/ MCO2 / TIM8_CH4/SDIO_D1 / /I2C3_SDA / DCMI_D3 / TIM3_CH4/ EVENTOUT	
41	67	100	119	F15	PA8	I/O	FT	PA8	MCO1 / USART1_CK/ TIM1_CH1/ I2C3_SCL/ OTG_FS_SOF/ EVENTOUT	
42	68	101	120	E15	PA9	I/O	FT	PA9	USART1_TX/ TIM1_CH2 / I2C3_SMBA / DCMI_D0/ EVENTOUT	OTG_FS_VBUS
43	69	102	121	D15	PA10	I/O	FT	PA10	USART1_RX/ TIM1_CH3/ OTG_FS_ID/DCMI_D1/ EVENTOUT	
44	70	103	122	C15	PA11	I/O	FT	PA11	USART1_CTS / CAN1_RX / TIM1_CH4 / OTG_FS_DM/ EVENTOUT	
45	71	104	123	B15	PA12	I/O	FT	PA12	USART1_RTS / CAN1_TX/ TIM1_ETR/ OTG_FS_DP/ EVENTOUT	
46	72	105	124	A15	PA13	I/O	FT	JTMS-SWDIO	JTMS-SWDIO/ EVENTOUT	
47	73	106	125	F13	V <sub>CAP_2</sub>	S		V <sub>CAP_2</sub>		
-	74	107	126	F12	V <sub>SS_2</sub>	S		V <sub>SS_2</sub>		
48	75	108	127	G13	V <sub>DD_2</sub>	S		V <sub>DD_2</sub>		
-	-	-	128	E12	PH13	I/O	FT	PH13	TIM8_CH1N / CAN1_TX/ EVENTOUT	
-	-	-	129	E13	PH14	I/O	FT	PH14	TIM8_CH2N / DCMI_D4/ EVENTOUT	
-	-	-	130	D13	PH15	I/O	FT	PH15	TIM8_CH3N / DCMI_D11/ EVENTOUT	
-	-	-	131	E14	PI0	I/O	FT	PI0	TIM5_CH4 / SPI2_NSS / I2S2_WS / DCMI_D13/ EVENTOUT	

Table 5. STM32F21x pin and ball definitions (continued)

Pins					Pin name	Type <sup>(1)</sup>		Main function <sup>(3)</sup> (after reset)	Alternate functions	Other functions
LQFP64	LQFP100	LQFP144	LQFP176	UFBGA176		I/O	Level <sup>(2)</sup>			
-	-	-	132	D14	PI1	I/O	FT	PI1	SPI2_SCK / I2S2_SCK / DCMI_D8/ EVENTOUT	
-	-	-	133	C14	PI2	I/O	FT	PI2	TIM8_CH4 / SPI2_MISO / DCMI_D9/ EVENTOUT	
-	-	-	134	C13	PI3	I/O	FT	PI3	TIM8_ETR / SPI2_MOSI / I2S2_SD / DCMI_D10/ EVENTOUT	
-	-	-	135	D9	V <sub>SS_15</sub>	S		V <sub>SS_15</sub>		
-	-	-	136	C9	V <sub>DD_15</sub>	S		V <sub>DD_15</sub>		
49	76	109	137	A14	PA14	I/O	FT	JTCK-SWCLK	JTCK-SWCLK/ EVENTOUT	
50	77	110	138	A13	PA15	I/O	FT	JTDI	JTDI/ SPI3_NSS/ I2S3_WS/TIM2_CH1_ETR / SPI1_NSS/ EVENTOUT	
51	78	111	139	B14	PC10	I/O	FT	PC10	SPI3_SCK / I2S3_SCK / UART4_TX / SDIO_D2 / DCMI_D8 / USART3_TX/ EVENTOUT	
52	79	112	140	B13	PC11	I/O	FT	PC11	UART4_RX/ SPI3_MISO / SDIO_D3 / DCMI_D4/USART3_RX/ EVENTOUT	
53	80	113	141	A12	PC12	I/O	FT	PC12	UART5_TX/SDIO_CK / DCMI_D9 / SPI3_MOSI / I2S3_SD / USART3_CK/ EVENTOUT	
-	81	114	142	B12	PD0	I/O	FT	PD0	FSMC_D2/CAN1_RX/ EVENTOUT	
-	82	115	143	C12	PD1	I/O	FT	PD1	FSMC_D3 / CAN1_TX/ EVENTOUT	
54	83	116	144	D12	PD2	I/O	FT	PD2	TIM3_ETR/UART5_RX SDIO_CMD / DCMI_D11/ EVENTOUT	
-	84	117	145	D11	PD3	I/O	FT	PD3	FSMC_CLK/USART2_CTS/ EVENTOUT	
-	85	118	146	D10	PD4	I/O	FT	PD4	FSMC_NOE/USART2_RTS/ EVENTOUT	
-	86	119	147	C11	PD5	I/O	FT	PD5	FSMC_NWE/USART2_TX/ EVENTOUT	
-	-	120	148	D8	V <sub>SS_10</sub>	S		V <sub>SS_10</sub>		
-	-	121	149	C8	V <sub>DD_10</sub>	S		V <sub>DD_10</sub>		

Table 5. STM32F21x pin and ball definitions (continued)

Pins					Pin name	Type <sup>(1)</sup>		Main function <sup>(3)</sup> (after reset)	Alternate functions	Other functions
LQFP64	LQFP100	LQFP144	LQFP176	UFBGA176		I/O	Level <sup>(2)</sup>			
-	87	122	150	B11	PD6	I/O	FT	PD6	FSMC_NWAIT/USART2_RX / EVENTOUT	
-	88	123	151	A11	PD7	I/O	FT	PD7	USART2_CK/FSMC_NE1/FSMC_NCE2/ EVENTOUT	
-	-	124	152	C10	PG9	I/O	FT	PG9	USART6_RX / FSMC_NE2/FSMC_NCE3/ EVENTOUT	
-	-	125	153	B10	PG10	I/O	FT	PG10	FSMC_NCE4_1/ FSMC_NE3/ EVENTOUT	
-	-	126	154	B9	PG11	I/O	FT	PG11	FSMC_NCE4_2 / ETH_MII_TX_EN / ETH_RMII_TX_EN/ EVENTOUT	
-	-	127	155	B8	PG12	I/O	FT	PG12	FSMC_NE4 / USART6_RTS/ EVENTOUT	
-	-	128	156	A8	PG13	I/O	FT	PG13	FSMC_A24 / USART6_CTS /ETH_MII_TXD0/ ETH_RMII_TXD0/ EVENTOUT	
-	-	129	157	A7	PG14	I/O	FT	PG14	FSMC_A25 / USART6_TX /ETH_MII_TXD1/ ETH_RMII_TXD1/ EVENTOUT	
-	-	130	158	D7	V <sub>SS_11</sub>	S		V <sub>SS_11</sub>		
-	-	131	159	C7	V <sub>DD_11</sub>	S		V <sub>DD_11</sub>		
-	-	132	160	B7	PG15	I/O	FT	PG15	USART6_CTS / DCMI_D13/ EVENTOUT	
55	89	133	161	A10	PB3	I/O	FT	JTDO/ TRACESWO	JTDO/ TRACESWO/ SPI3_SCK / I2S3_SCK / TIM2_CH2 / SPI1_SCK/ EVENTOUT	
56	90	134	162	A9	PB4	I/O	FT	NJTRST	NJTRST/ SPI3_MISO / TIM3_CH1 / SPI1_MISO/ EVENTOUT	
57	91	135	163	A6	PB5	I/O	FT	PB5	I2C1_SMBA/ CAN2_RX / OTG_HS_ULPI_D7 / ETH_PPS_OUT/TIM3_CH2/ SPI1_MOSI/ SPI3_MOSI / DCMI_D10 / I2S3_SD/ EVENTOUT	



Table 5. STM32F21x pin and ball definitions (continued)

Pins					Pin name	Type <sup>(1)</sup>	I / O Level <sup>(2)</sup>	Main function <sup>(3)</sup> (after reset)	Alternate functions	Other functions
LQFP64	LQFP100	LQFP144	LQFP176	UFBGA176						
58	92	136	164	B6	PB6	I/O	FT	PB6	I2C1_SCL/ TIM4_CH1 / CAN2_TX / DCMI_D5/USART1_TX/ EVENTOUT	
59	93	137	165	B5	PB7	I/O	FT	PB7	I2C1_SDA / FSMC_NL <sup>(8)</sup> / DCMI_VSYNC / USART1_RX/ TIM4_CH2/ EVENTOUT	
60	94	138	166	D6	BOOT0	I		BOOT0		V <sub>PP</sub>
61	95	139	167	A5	PB8	I/O	FT	PB8	TIM4_CH3/SDIO_D4/ TIM10_CH1 / DCMI_D6 / ETH_MII_TXD3 / I2C1_SCL/ CAN1_RX/ EVENTOUT	
62	96	140	168	B4	PB9	I/O	FT	PB9	SPI2_NSS/ I2S2_WS/ TIM4_CH4/ TIM11_CH1/ SDIO_D5 / DCMI_D7 / I2C1_SDA / CAN1_TX/ EVENTOUT	
-	97	141	169	A4	PE0	I/O	FT	PE0	TIM4_ETR / FSMC_NBL0 / DCMI_D2/ EVENTOUT	
-	98	142	170	A3	PE1	I/O	FT	PE1	FSMC_NBL1 / DCMI_D3/ EVENTOUT	
-	-	-	-	D5	V <sub>SS</sub>	S		V <sub>SS</sub>		
63	-	-	-	-	V <sub>SS_3</sub>	S		V <sub>SS_3</sub>		
-	99	143	171	C6	RFU <sup>(9)</sup>					
64	100	144	172	C5	V <sub>DD_3</sub>	S		V <sub>DD_3</sub>		
-	-	-	173	D4	PI4	I/O	FT	PI4	TIM8_BKIN / DCMI_D5/ EVENTOUT	
-	-	-	174	C4	PI5	I/O	FT	PI5	TIM8_CH1 / DCMI_VSYNC/ EVENTOUT	
-	-	-	175	C3	PI6	I/O	FT	PI6	TIM8_CH2 / DCMI_D6/ EVENTOUT	
-	-	-	176	C2	PI7	I/O	FT	PI7	TIM8_CH3 / DCMI_D7/ EVENTOUT	

1. I = input, O = output, S = supply, HiZ = high impedance.
2. FT = 5 V tolerant; TT = 3.6 V tolerant.
3. Function availability depends on the chosen device.
4. PC13, PC14, PC15 and PI8 are supplied through the power switch. Since the switch only sinks a limited amount of current (3 mA), the use of GPIOs PC13 to PC15 and PI8 in output mode is limited: the speed should not exceed 2 MHz with a maximum load of 30 pF and these I/Os must not be used as a current source (e.g. to drive an LED).

5. Main function after the first backup domain power-up. Later on, it depends on the contents of the RTC registers even after reset (because these registers are not reset by the main reset). For details on how to manage these I/Os, refer to the RTC register description sections in the STM32F20x and STM32F21x reference manual, available from the STMicroelectronics website: [www.st.com](http://www.st.com).
6. FT = 5 V tolerant except when in analog mode or oscillator mode (for PC14, PC15, PH0 and PH1).
7. If the device is delivered in an UFBGA176 package and if the REGOFF pin is set to  $V_{DD}$  (Regulator OFF), then PA0 is used as an internal Reset (active low).
8. FSMC\_NL pin is also named FSMC\_NADV on memory devices.
9. RFU means "reserved for future use". This pin can be tied to  $V_{DD}$ ,  $V_{SS}$  or left unconnected.



Table 6. Alternate function mapping

Port	AF0	AF1	AF2	AF3	AF4	AF5	AF6	AF7	AF8	AF9	AF10	AF11	AF12	AF13	AF14	AF15
	SYS	TIM1/2	TIM3/4/5	TIM8/9/10/11	I2C1/I2C2/I2C3	SPI1/SPI2/I2S2	SPI3/I2S3	USART1/2/3	UART4/5/ USART6	CAN1/CAN2/ TIM12/13/14	OTG_FS/ OTG_HS	ETH	FSMC/SDIO/ OTG_HS	DCMI		
PA0-WKUP		TIM2_CH1 TIM2_ETR	TIM5_CH1	TIM8_ETR				USART2_CTS	UART4_TX			ETH_MII_CRS				EVENTOUT
PA1		TIM2_CH2	TIM5_CH2					USART2_RTS	UART4_RX			ETH_MII_RX_CLK ETH_RMII _REF_CLK				EVENTOUT
PA2		TIM2_CH3	TIM5_CH3	TIM9_CH1				USART2_TX				ETH_MDIO				EVENTOUT
PA3		TIM2_CH4	TIM5_CH4	TIM9_CH2				USART2_RX			OTG_HS_ULPI_D0	ETH_MII_COL				EVENTOUT
PA4						SPI1_NSS	SPI3_NSS I2S3_WS	USART2_CK					OTG_HS_SOF	DCMI_HSYNC		EVENTOUT
PA5		TIM2_CH1 TIM2_ETR		TIM8_CH1N		SPI1_SCK					OTG_HS_ULPI_CK					EVENTOUT
PA6		TIM1_BKIN	TIM3_CH1	TIM8_BKIN		SPI1_MISO				TIM13_CH1				DCMI_PIXCK		EVENTOUT
PA7		TIM1_CH1N	TIM3_CH2	TIM8_CH1N		SPI1_MOSI				TIM14_CH1		ETH_MII_RX_DV ETH_RMII _CRS_DV				EVENTOUT
PA8	MCO1	TIM1_CH1			I2C3_SCL			USART1_CK			OTG_FS_SOF					EVENTOUT
PA9		TIM1_CH2			I2C3_SMBA			USART1_TX						DCMI_D0		EVENTOUT
PA10		TIM1_CH3						USART1_RX			OTG_FS_ID			DCMI_D1		EVENTOUT
PA11		TIM1_CH4						USART1_CTS		CAN1_RX	OTG_FS_DM					EVENTOUT
PA12		TIM1_ETR						USART1_RTS		CAN1_TX	OTG_FS_DP					EVENTOUT
PA13	JTMS-SWDIO															EVENTOUT
PA14	JTCK-SWCLK															EVENTOUT
PA15	JTDI	TIM2_CH1 TIM2_ETR				SPI1_NSS	SPI3_NSS I2S3_WS									EVENTOUT
PB0		TIM1_CH2N	TIM3_CH3	TIM8_CH2N							OTG_HS_ULPI_D1	ETH_MII_RXD2				EVENTOUT
PB1		TIM1_CH3N	TIM3_CH4	TIM8_CH3N							OTG_HS_ULPI_D2	ETH_MII_RXD3	OTG_HS_INTN			EVENTOUT
PB2																EVENTOUT
PB3	JTDO/ TRACESWO	TIM2_CH2				SPI1_SCK	SPI3_SCK I2S3_SCK									EVENTOUT
PB4	JTRST		TIM3_CH1			SPI1_MISO	SPI3_MISO									EVENTOUT
PB5			TIM3_CH2		I2C1_SMBA	SPI1_MOSI	SPI3_MOSI I2S3_SD			CAN2_RX	OTG_HS_ULPI_D7	ETH_PP_OUT		DCMI_D10		EVENTOUT
PB6			TIM4_CH1		I2C1_SCL			USART1_TX		CAN2_TX				DCMI_D5		EVENTOUT
PB7			TIM4_CH2		I2C1_SDA			USART1_RX					FSMC_NL	DCMI_VSYNC		EVENTOUT
PB8			TIM4_CH3	TIM10_CH1	I2C1_SCL					CAN1_RX		ETH_MII_TXD3	SDIO_D4	DCMI_D6		EVENTOUT
PB9			TIM4_CH4	TIM11_CH1	I2C1_SDA	SPI2_NSS I2S2_WS				CAN1_TX			SDIO_D5	DCMI_D7		EVENTOUT
PB10		TIM2_CH3			I2C2_SCL	SPI2_SCK I2S2_SCK		USART3_TX			OTG_HS_ULPI_D8	ETH_MII_RX_ER	OTG_HS_SCL			EVENTOUT
PB11		TIM2_CH4			I2C2_SDA			USART3_RX			OTG_HS_ULPI_D9	ETH_MII_TX_EN ETH_RMII_TX_EN	OTG_HS_SDA			EVENTOUT
PB12		TIM1_BKIN			I2C2_SMBA	SPI2_NSS I2S2_WS		USART3_CK		CAN2_RX	OTG_HS_ULPI_D5	ETH_MII_TXD0 ETH_RMII_TXD0	OTG_HS_ID			EVENTOUT
PB13		TIM1_CH1N				SPI2_SCK I2S2_SCK		USART3_CTS		CAN2_TX	OTG_HS_ULPI_D6	ETH_MII_TXD1 ETH_RMII_TXD1				EVENTOUT



**Table 6. Alternate function mapping (continued)**

Port	AF0	AF1	AF2	AF3	AF4	AF5	AF6	AF7	AF8	AF9	AF10	AF11	AF12	AF13	AF014	AF15
	SYS	TIM1/2	TIM3/4/5	TIM8/9/10/11	I2C1/I2C2/I2C3	SP1/SPI2/I2S2	SPI3/I2S3	USART1/2/3	UART4/5/ USART6	CAN1/CAN2/ TIM12/13/14	OTG_FS/ OTG_HS	ETH	FSMC/SDIO/ OTG_HS	DCMI		
PB14		TIM1_CH2N		TIM8_CH2N		SPI2_MISO		USART3_RTS		TIM12_CH1			OTG_HS_DM			EVENTOUT
PB15	RTC_50Hz	TIM1_CH3N		TIM8_CH3N		SPI2_MOSI I2S2_SD				TIM12_CH2			OTG_HS_DP			EVENTOUT
PC0											OTG_HS_ULPI_STP					EVENTOUT
PC1												ETH_MDC				EVENTOUT
PC2						SPI2_MISO					OTG_HS_ULPI_DIR	ETH_MII_TXD2				EVENTOUT
PC3						SPI2_MOSI					OTG_HS_ULPI_NXT1	ETH_MII_TX_CLK				EVENTOUT
PC4												ETH_MII_RXD0 ETH_RMII_RXD0				EVENTOUT
PC5												ETH_MII_RXD1 ETH_RMII_RXD1				EVENTOUT
PC6			TIM3_CH1	TIM8_CH1		I2S2_MCK			USART6_TX				SDIO_D6	DCMI_D0		EVENTOUT
PC7			TIM3_CH2	TIM8_CH2			I2S3_MCK		USART6_RX				SDIO_D7	DCMI_D1		EVENTOUT
PC8			TIM3_CH3	TIM8_CH3					USART6_CK				SDIO_D0	DCMI_D2		EVENTOUT
PC9	MCO2		TIM3_CH4	TIM8_CH4	I2C3_SDA	I2S2_CKIN	I2S3_CKIN						SDIO_D1	DCMI_D3		EVENTOUT
PC10						SPI3_SCK I2S3_SCK		USART3_TX	UART4_TX				SDIO_D2	DCMI_D8		EVENTOUT
PC11						SPI3_MISO		USART3_RX	UART4_RX				SDIO_D3	DCMI_D4		EVENTOUT
PC12						SPI3_MOSI I2S3_SD		USART3_CK	UART5_TX				SDIO_CK	DCMI_D9		EVENTOUT
PC13																
PC14-OSC32_IN																
PC15-OSC32_OUT																
PD0										CAN1_RX			FSMC_D2			EVENTOUT
PD1										CAN1_TX			FSMC_D3			EVENTOUT
PD2			TIM3_ETR						UART5_RX				SDIO_CMD	DCMI_D11		EVENTOUT
PD3								USART2_CTS					FSMC_CLK			EVENTOUT
PD4								USART2_RTS					FSMC_NOE			EVENTOUT
PD5								USART2_TX					FSMC_NWE			EVENTOUT
PD6								USART2_RX					FSMC_NWAIT			EVENTOUT
PD7								USART2_CK					FSMC_NE1/ FSMC_NCE2			EVENTOUT
PD8								USART3_TX					FSMC_D13			EVENTOUT
PD9								USART3_RX					FSMC_D14			EVENTOUT
PD10								USART3_CK					FSMC_D15			EVENTOUT
PD11								USART3_CTS					FSMC_A16			EVENTOUT
PD12			TIM4_CH1					USART3_RTS					FSMC_A17			EVENTOUT
PD13			TIM4_CH2										FSMC_A18			EVENTOUT


**Table 6. Alternate function mapping (continued)**

Port	AF0	AF1	AF2	AF3	AF4	AF5	AF6	AF7	AF8	AF9	AF10	AF11	AF12	AF13	AF014	AF15
	SYS	TIM1/2	TIM3/4/5	TIM8/9/10/11	I2C1/I2C2/I2C3	SP11/SP12/I2S2	SP13/I2S3	USART1/2/3	UART4/5/ USART6	CAN1/CAN2/ TIM12/13/14	OTG_FS/ OTG_HS	ETH	FSMC/SDIO/ OTG_HS	DCMI		
PD14			TIM4_CH3										FSMC_D0			EVENTOUT
PD15			TIM4_CH4										FSMC_D1			EVENTOUT
PE0			TIM4_ETR										FSMC_NBL0	DCMI_D2		EVENTOUT
PE1													FSMC_BLN1	DCMI_D3		EVENTOUT
PE2	TRACECLK											ETH_MII_TXD3				EVENTOUT
PE3	TRACED0												FSMC_A19			EVENTOUT
PE4	TRACED1												FSMC_A20	DCMI_D4		EVENTOUT
PE5	TRACED2			TIM9_CH1									FSMC_A21	DCMI_D6		EVENTOUT
PE6	TRACED3			TIM9_CH2									FSMC_A22	DCMI_D7		EVENTOUT
PE7		TIM1_ETR											FSMC_D4			EVENTOUT
PE8		TIM1_CH1N											FSMC_D5			EVENTOUT
PE9		TIM1_CH1											FSMC_D6			EVENTOUT
PE10		TIM1_CH2N											FSMC_D7			EVENTOUT
PE11		TIM1_CH2											FSMC_D8			EVENTOUT
PE12		TIM1_CH3N											FSMC_D9			EVENTOUT
PE13		TIM1_CH3											FSMC_D10			EVENTOUT
PE14		TIM1_CH4											FSMC_D11			EVENTOUT
PE15		TIM1_BKIN											FSMC_D12			EVENTOUT
PF0					I2C2_SDA								FSMC_A0			EVENTOUT
PF1					I2C2_SCL								FSMC_A1			EVENTOUT
PF2					I2C2_SMBA								FSMC_A2			EVENTOUT
PF3													FSMC_A3			EVENTOUT
PF4													FSMC_A4			EVENTOUT
PF5													FSMC_A5			EVENTOUT
PF6				TIM10_CH1									FSMC_NIORD			EVENTOUT
PF7				TIM11_CH1									FSMC_NREG			EVENTOUT
PF8										TIM13_CH1			FSMC_NIOWR			EVENTOUT
PF9										TIM14_CH1			FSMC_CD			EVENTOUT
PF10													FSMC_INTR			EVENTOUT
PF11														DCMI_D12		EVENTOUT
PF12													FSMC_A6			EVENTOUT
PF13													FSMC_A7			EVENTOUT
PF14													FSMC_A8			EVENTOUT



**Table 6. Alternate function mapping (continued)**

Port	AF0	AF1	AF2	AF3	AF4	AF5	AF6	AF7	AF8	AF9	AF10	AF11	AF12	AF13	AF014	AF15
	SYS	TIM1/2	TIM3/4/5	TIM8/9/10/11	I2C1/I2C2/I2C3	SP11/SP12/I2S2	SP13/I2S3	USART1/2/3	UART4/5/ USART6	CAN1/CAN2/ TIM12/13/14	OTG_FS/ OTG_HS	ETH	FSMC/SDIO/ OTG_HS	DCMI		
PF15													FSMC_A9			EVENTOUT
PG0													FSMC_A10			EVENTOUT
PG1													FSMC_A11			EVENTOUT
PG2													FSMC_A12			EVENTOUT
PG3													FSMC_A13			EVENTOUT
PG4													FSMC_A14			EVENTOUT
PG5													FSMC_A15			EVENTOUT
PG6													FSMC_INT2			EVENTOUT
PG7									USART6_CK				FSMC_INT3			EVENTOUT
PG8									USART6_RTS			ETH_PPS_OUT				EVENTOUT
PG9									USART6_RX				FSMC_NE2/ FSMC_NCE3			EVENTOUT
PG10													FSMC_NCE4_1/ FSMC_NCE3			EVENTOUT
PG11												ETH_MII_TX_EN ETH_RMII_TX_EN	FSMC_NCE4_2			EVENTOUT
PG12									USART6_RTS				FSMC_NE4			EVENTOUT
PG13									USART6_CTS			ETH_MII_TXD0 ETH_RMII_TXD0	FSMC_A24			EVENTOUT
PG14									USART6_TX			ETH_MII_TXD1 ETH_RMII_TXD1	FSMC_A25			EVENTOUT
PG15									USART6_CTS					DCMI_D13		EVENTOUT
PH0 - OSC_IN																
PH1 - OSC_OUT																
PH2												ETH_MII_CRFS				EVENTOUT
PH3												ETH_MII_COL				EVENTOUT
PH4					I2C2_SCL						OTG_HS_ULPI_NXT					EVENTOUT
PH5					I2C2_SDA											EVENTOUT
PH6					I2C2_SMBA					TIM12_CH1		ETH_MII_RXD2				EVENTOUT
PH7					I2C3_SCL							ETH_MII_RXD3				EVENTOUT
PH8					I2C3_SDA									DCMI_HSYNC		EVENTOUT
PH9					I2C3_SMBA					TIM12_CH2				DCMI_D0		EVENTOUT
PH10			TIM5_CH1	TIM5_ETR										DCMI_D1		EVENTOUT
PH11			TIM5_CH2											DCMI_D2		EVENTOUT
PH12			TIM5_CH3											DCMI_D3		EVENTOUT
PH13				TIM8_CH1N						CAN1_TX						EVENTOUT


**Table 6. Alternate function mapping (continued)**

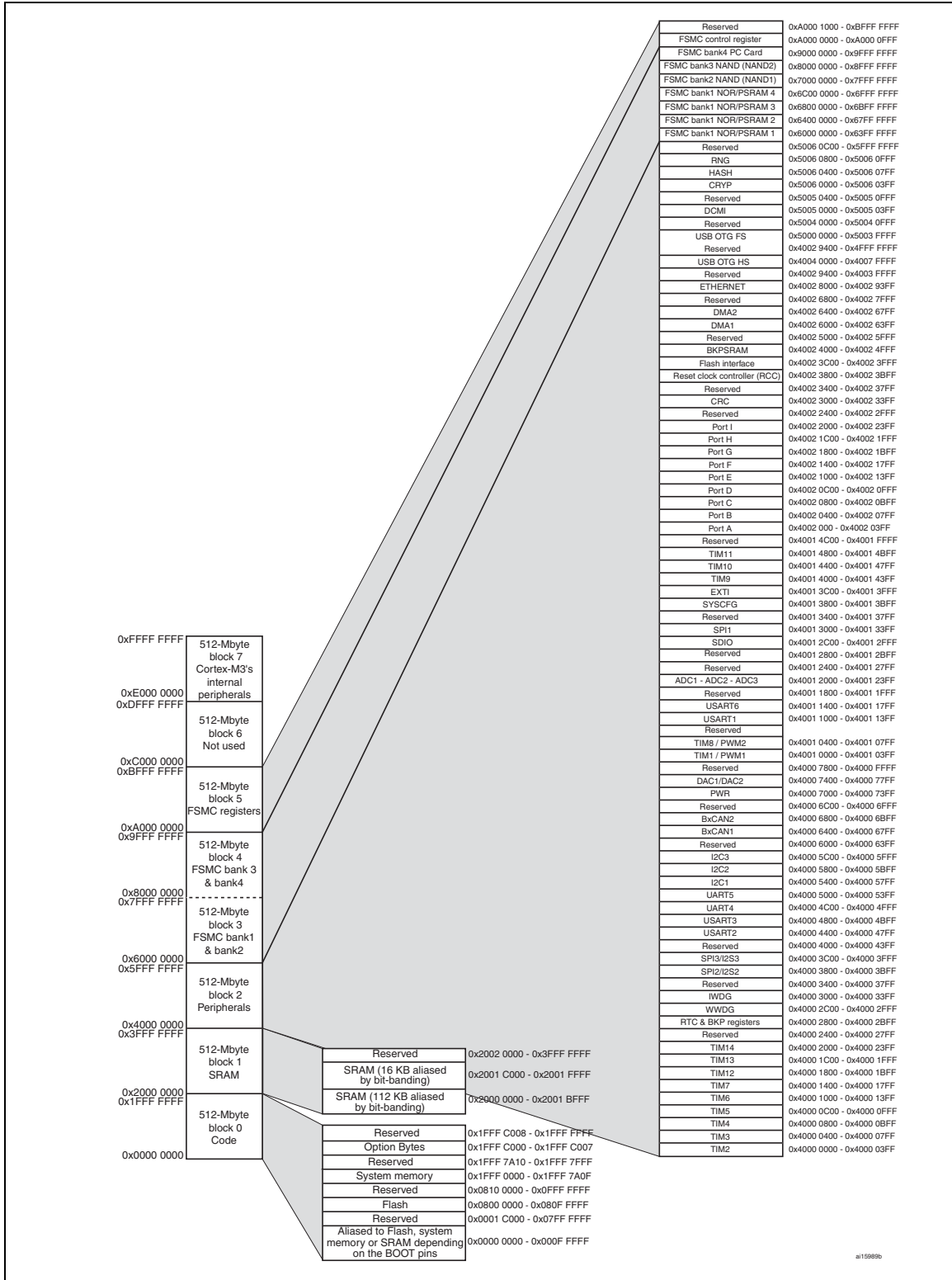
Port	AF0	AF1	AF2	AF3	AF4	AF5	AF6	AF7	AF8	AF9	AF10	AF11	AF12	AF13	AF14	AF15
	SYS	TIM1/2	TIM3/4/5	TIM8/9/10/11	I2C1/I2C2/I2C3	SPI1/SPI2/I2S2	SPI3/I2S3	USART1/2/3	UART4/5/ USART6	CAN1/CAN2/ TIM12/13/14	OTG_FS/ OTG_HS	ETH	FSMC/SDIO/ OTG_HS	DCMI		
PH14				TIM8_CH2N										DCMI_D4		EVENTOUT
PH15				TIM8_CH3N										DCMI_D11		EVENTOUT
PI0			TIM5_CH4			SPI2_NSS I2S2_WS								DCMI_D13		EVENTOUT
PI1						SPI2_SCK I2S2_SCK								DCMI_D8		EVENTOUT
PI2				TIM8_CH4		SPI2_MISO								DCMI_D9		EVENTOUT
PI3				TIM8_ETR		SPI2_MOSI I2S2_SD								DCMI_D10		EVENTOUT
PI4				TIM8_BKIN										DCMI_D5		EVENTOUT
PI5				TIM8_CH1										DCMI_VSYNC		EVENTOUT
PI6				TIM8_CH2										DCMI_D6		EVENTOUT
PI7				TIM8_CH3										DCMI_D7		EVENTOUT
PI8																
PI9										CAN1_RX						EVENTOUT
PI10												ETH_MII_RX_ER				EVENTOUT
PI11											OTG_HS_ULPI_DIR					EVENTOUT

## 4 Memory mapping

The memory map is shown in [Figure 14](#).



Figure 14. Memory map



## 5 Electrical characteristics

### 5.1 Parameter conditions

Unless otherwise specified, all voltages are referenced to  $V_{SS}$ .

#### 5.1.1 Minimum and maximum values

Unless otherwise specified the minimum and maximum values are guaranteed in the worst conditions of ambient temperature, supply voltage and frequencies by tests in production on 100% of the devices with an ambient temperature at  $T_A = 25\text{ }^\circ\text{C}$  and  $T_A = T_{Amax}$  (given by the selected temperature range).

Data based on characterization results, design simulation and/or technology characteristics are indicated in the table footnotes and are not tested in production. Based on characterization, the minimum and maximum values refer to sample tests and represent the mean value plus or minus three times the standard deviation ( $\text{mean} \pm 3\Sigma$ ).

#### 5.1.2 Typical values

Unless otherwise specified, typical data are based on  $T_A = 25\text{ }^\circ\text{C}$ ,  $V_{DD} = 3.3\text{ V}$  (for the  $1.8\text{ V} \leq V_{DD} \leq 3.6\text{ V}$  voltage range). They are given only as design guidelines and are not tested.

Typical ADC accuracy values are determined by characterization of a batch of samples from a standard diffusion lot over the full temperature range, where 95% of the devices have an error less than or equal to the value indicated ( $\text{mean} \pm 2\Sigma$ ).

#### 5.1.3 Typical curves

Unless otherwise specified, all typical curves are given only as design guidelines and are not tested.

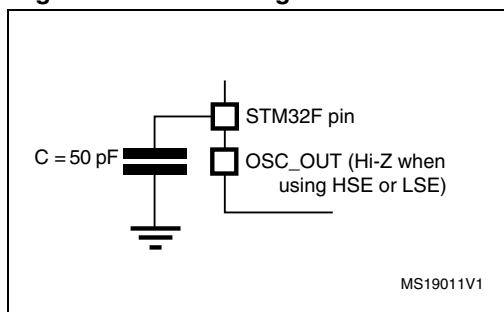
#### 5.1.4 Loading capacitor

The loading conditions used for pin parameter measurement are shown in [Figure 15](#).

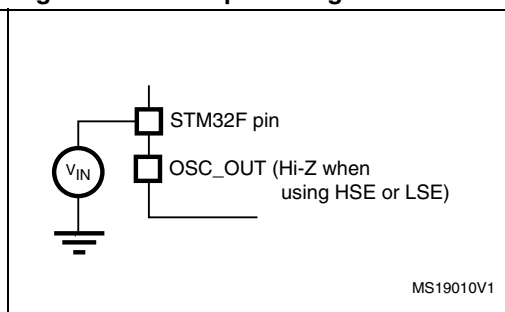
#### 5.1.5 Pin input voltage

The input voltage measurement on a pin of the device is described in [Figure 16](#).

**Figure 15. Pin loading conditions**

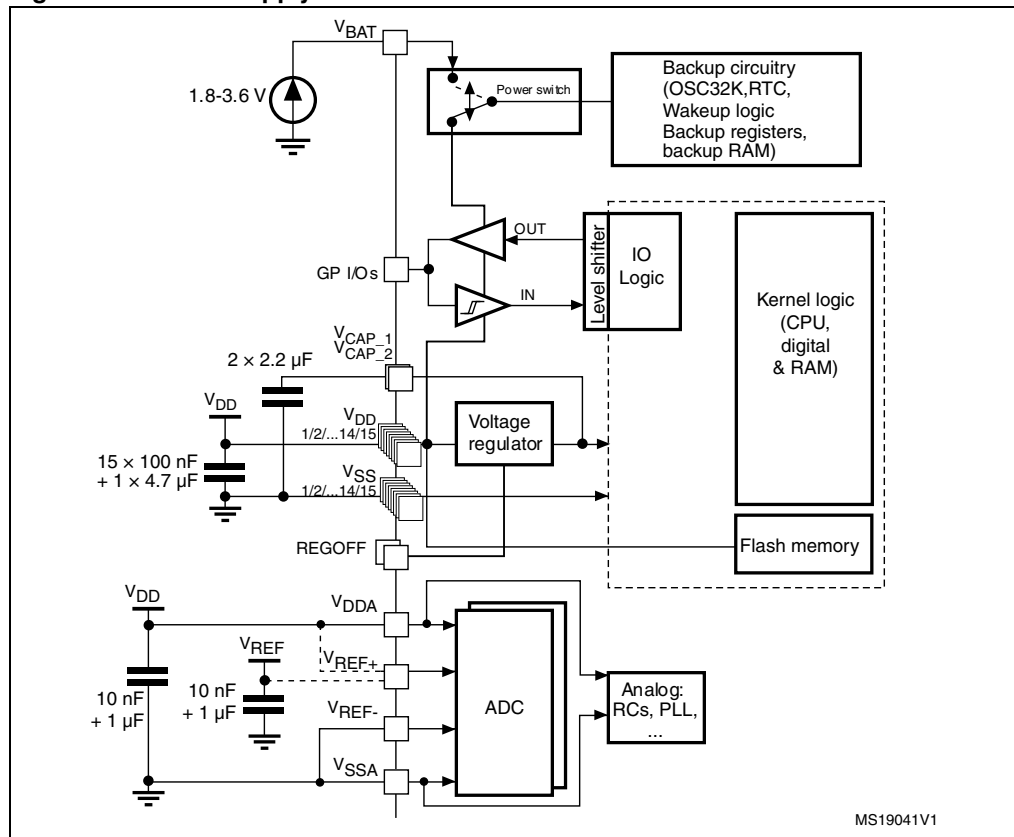


**Figure 16. Pin input voltage**



### 5.1.6 Power supply scheme

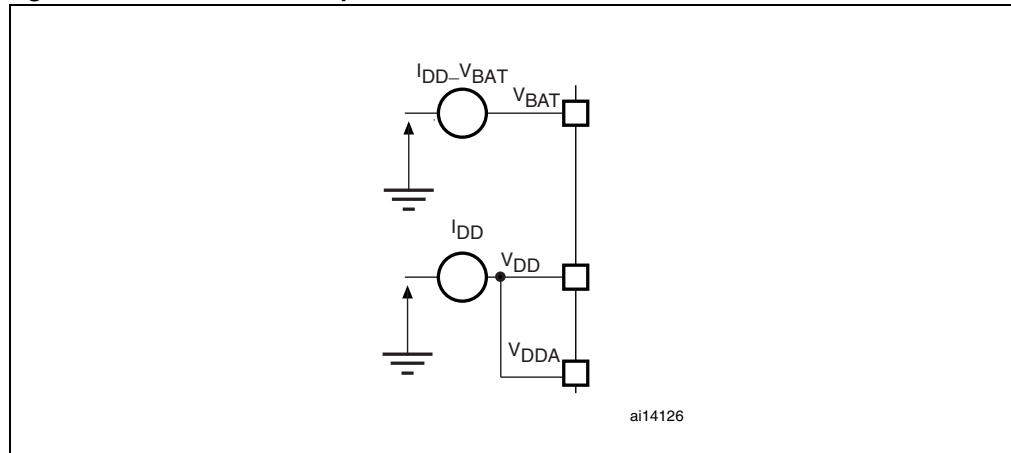
Figure 17. Power supply scheme



1. Each power supply pair must be decoupled with filtering ceramic capacitors as shown above. These capacitors must be placed as close as possible to, or below, the appropriate pins on the underside of the PCB to ensure the good functionality of the device.
2. To connect REGOFF pin, refer to [Section 2.2.16: Voltage regulator](#).
3. The two 2.2  $\mu\text{F}$  ceramic capacitors should not be connected when the voltage regulator is OFF.
4. The 4.7  $\mu\text{F}$  ceramic capacitor must be connected to one of the  $V_{\text{DD}}$  pin.

### 5.1.7 Current consumption measurement

Figure 18. Current consumption measurement scheme



## 5.2 Absolute maximum ratings

Stresses above the absolute maximum ratings listed in [Table 7: Voltage characteristics](#), [Table 8: Current characteristics](#), and [Table 9: Thermal characteristics](#) may cause permanent damage to the device. These are stress ratings only and functional operation of the device at these conditions is not implied. Exposure to maximum rating conditions for extended periods may affect device reliability.

Table 7. Voltage characteristics

Symbol	Ratings	Min	Max	Unit
$V_{DD}-V_{SS}$	External main supply voltage (including $V_{DDA}$ , $V_{DD}$ ) <sup>(1)</sup>	-0.3	4.0	V
$V_{IN}$	Input voltage on five-volt tolerant pin <sup>(2)</sup>	$V_{SS}-0.3$	$V_{DD}+4$	
	Input voltage on any other pin	$V_{SS}-0.3$	4.0	
$ \Delta V_{DDx} $	Variations between different $V_{DD}$ power pins	-	50	mV
$ V_{SSx} - V_{SS} $	Variations between all the different ground pins	-	50	
$V_{ESD(HBM)}$	Electrostatic discharge voltage (human body model)	see <a href="#">Section 5.3.14: Absolute maximum ratings (electrical sensitivity)</a>		

- All main power ( $V_{DD}$ ,  $V_{DDA}$ ) and ground ( $V_{SS}$ ,  $V_{SSA}$ ) pins must always be connected to the external power supply, in the permitted range.
- $V_{IN}$  maximum value must always be respected. Refer to [Table 8](#) for the values of the maximum allowed injected current.

**Table 8. Current characteristics**

Symbol	Ratings	Max.	Unit
$I_{VDD}$	Total current into $V_{DD}$ power lines (source) <sup>(1)</sup>	120	mA
$I_{VSS}$	Total current out of $V_{SS}$ ground lines (sink) <sup>(1)</sup>	120	
$I_{IO}$	Output current sunk by any I/O and control pin	25	
	Output current source by any I/Os and control pin	25	
$I_{INJ(PIN)}$ <sup>(2)</sup>	Injected current on five-volt tolerant I/O <sup>(3)</sup>	-5/+0	
	Injected current on any other pin <sup>(4)</sup>	±5	
$\Sigma I_{INJ(PIN)}$ <sup>(4)</sup>	Total injected current (sum of all I/O and control pins) <sup>(5)</sup>	±25	

- All main power ( $V_{DD}$ ,  $V_{DDA}$ ) and ground ( $V_{SS}$ ,  $V_{SSA}$ ) pins must always be connected to the external power supply, in the permitted range.
- Negative injection disturbs the analog performance of the device. See note in [Section 5.3.20: 12-bit ADC characteristics](#).
- Positive injection is not possible on these I/Os. A negative injection is induced by  $V_{IN} < V_{SS}$ .  $I_{INJ(PIN)}$  must never be exceeded. Refer to [Table 7](#) for the values of the maximum allowed input voltage.
- A positive injection is induced by  $V_{IN} > V_{DD}$  while a negative injection is induced by  $V_{IN} < V_{SS}$ .  $I_{INJ(PIN)}$  must never be exceeded. Refer to [Table 7](#) for the values of the maximum allowed input voltage.
- When several inputs are submitted to a current injection, the maximum  $\Sigma I_{INJ(PIN)}$  is the absolute sum of the positive and negative injected currents (instantaneous values).

**Table 9. Thermal characteristics**

Symbol	Ratings	Value	Unit
$T_{STG}$	Storage temperature range	-65 to +150	°C
$T_J$	Maximum junction temperature	125	°C

## 5.3 Operating conditions

### 5.3.1 General operating conditions

**Table 10. General operating conditions**

Symbol	Parameter	Conditions	Min	Max	Unit
$f_{HCLK}$	Internal AHB clock frequency		0	120	MHz
$f_{PCLK1}$	Internal APB1 clock frequency		0	30	
$f_{PCLK2}$	Internal APB2 clock frequency		0	60	
$V_{DD}$	Standard operating voltage		1.8	3.6	V
$V_{DDA}$ <sup>(1)</sup>	Analog operating voltage (ADC limited to 1 M samples)	Must be the same potential as $V_{DD}$ <sup>(2)</sup>	1.8	3.6	V
	Analog operating voltage (ADC limited to 2 M samples)		2.4	3.6	
$V_{BAT}$	Backup operating voltage		1.65	3.6	V

Table 10. General operating conditions (continued)

Symbol	Parameter	Conditions	Min	Max	Unit
$V_{CAP1}$	Internal core voltage to be supplied externally in REGOFF mode		1.1	1.3	V
$V_{CAP2}$					
$P_D$	Power dissipation at $T_A = 85\text{ °C}$ for suffix 6 or $T_A = 105\text{ °C}$ for suffix 7 <sup>(3)</sup>	LQFP64	-	444	mW
		LQFP100	-	434	
		LQFP144	-	500	
		LQFP176	-	526	
		UFBGA176	-	513	
$T_A$	Ambient temperature for 6 suffix version	Maximum power dissipation	-40	85	°C
		Low power dissipation <sup>(4)</sup>	-40	105	
	Ambient temperature for 7 suffix version	Maximum power dissipation	-40	105	°C
		Low power dissipation <sup>(4)</sup>	-40	125	
$T_J$	Junction temperature range	6 suffix version	-40	105	°C
		7 suffix version	-40	125	

1. When the ADC is used, refer to [Table 62: ADC characteristics](#).
2. It is recommended to power  $V_{DD}$  and  $V_{DDA}$  from the same source. A maximum difference of 300 mV between  $V_{DD}$  and  $V_{DDA}$  can be tolerated during power-up and power-down operation.
3. If  $T_A$  is lower, higher  $P_D$  values are allowed as long as  $T_J$  does not exceed  $T_{Jmax}$ .
4. In low power dissipation state,  $T_A$  can be extended to this range as long as  $T_J$  does not exceed  $T_{Jmax}$ .

Table 11. Limitations depending on the operating power supply range

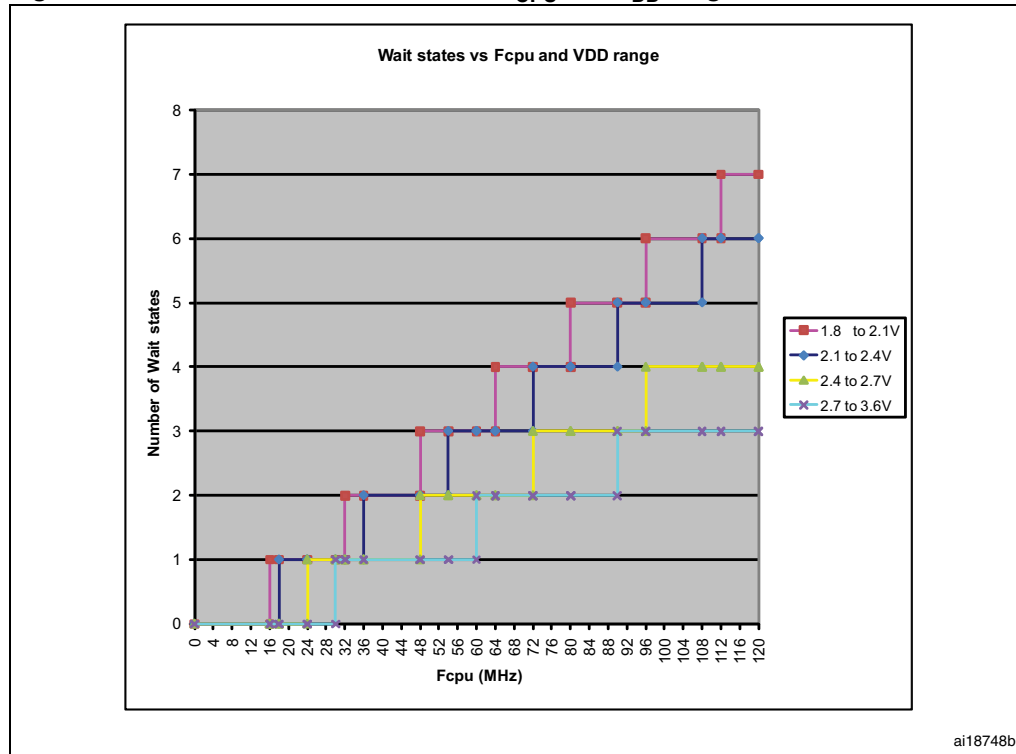
Operating power supply range	ADC operation	Maximum Flash memory access frequency ( $f_{Flashmax}$ )	Number of wait states at maximum CPU frequency ( $f_{CPUmax}=120\text{ MHz}$ ) <sup>(1)</sup>	I/O operation	FSMC controller operation	Possible Flash memory operations
$V_{DD} = 1.8$ to $2.1\text{ V}$	Conversion time up to 1 Msps	16 MHz with no Flash memory wait state	7 <sup>(2)</sup>	<ul style="list-style-type: none"> <li>- Degraded speed performance</li> <li>- No I/O compensation</li> </ul>	up to 30 MHz	8-bit erase and program operations only
$V_{DD} = 2.1$ to $2.4\text{ V}$	Conversion time up to 1 Msps	18 MHz with no Flash memory wait state	6 <sup>(2)</sup>	<ul style="list-style-type: none"> <li>- Degraded speed performance</li> <li>- No I/O compensation</li> </ul>	up to 30 MHz	16-bit erase and program operations

Table 11. Limitations depending on the operating power supply range

Operating power supply range	ADC operation	Maximum Flash memory access frequency ( $f_{\text{Flashmax}}$ )	Number of wait states at maximum CPU frequency ( $f_{\text{CPUmax}}=120\text{ MHz}$ ) <sup>(1)</sup>	I/O operation	FSMC controller operation	Possible Flash memory operations
$V_{\text{DD}} = 2.4$ to $2.7\text{ V}$	Conversion time up to 2 Msps	24 MHz with no Flash memory wait state	4 <sup>(2)</sup>	<ul style="list-style-type: none"> <li>– Degraded speed performance</li> <li>– I/O compensation works</li> </ul>	up to 48 MHz	16-bit erase and program operations
$V_{\text{DD}} = 2.7$ to $3.6\text{ V}$ <sup>(3)</sup>	Conversion time up to 2 Msps	30 MHz with no Flash memory wait state	3 <sup>(2)</sup>	<ul style="list-style-type: none"> <li>– Full-speed operation</li> <li>– I/O compensation works</li> </ul>	<ul style="list-style-type: none"> <li>– up to 60 MHz when <math>V_{\text{DD}} = 3.0</math> to <math>3.6\text{ V}</math></li> <li>– up to 48 MHz when <math>V_{\text{DD}} = 2.7</math> to <math>3.0\text{ V}</math></li> </ul>	32-bit erase and program operations

1. The number of wait states can be reduced by reducing the CPU frequency (see [Figure 19](#)).
2. Thanks to the ART accelerator and the 128-bit Flash memory, the number of wait states given here does not impact the execution speed from Flash memory since the ART accelerator allows to achieve a performance equivalent to 0 wait state program execution.
3. The voltage range for OTG USB FS can drop down to 2.7 V. However it is degraded between 2.7 and 3 V.

Figure 19. Number of wait states versus  $f_{CPU}$  and  $V_{DD}$  range

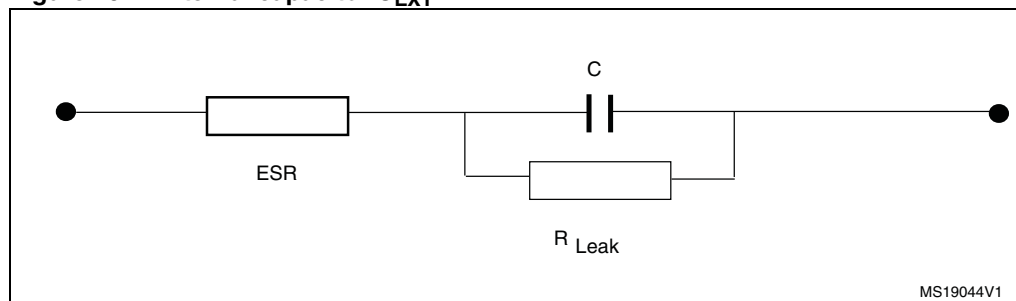


ai18748b

### 5.3.2 VCAP1/VCAP2 external capacitor

Stabilization for the main regulator is achieved by connecting an external capacitor to the VCAP1/VCAP2 pins.  $C_{EXT}$  is specified in [Table 12](#).

Figure 20. External capacitor  $C_{EXT}$



MS19044V1

1. Legend: ESR is the equivalent series resistance.

Table 12. VCAP1/VCAP2 operating conditions

Symbol	Parameter	Conditions
C <sub>EXT</sub>	Capacitance of external capacitor	2.2 $\mu$ F
ESR	ESR of external capacitor	< 2 $\Omega$



### 5.3.3 Operating conditions at power-up / power-down (regulator ON)

Subject to general operating conditions for  $T_A$ .

**Table 13. Operating conditions at power-up / power-down (regulator ON)**

Symbol	Parameter	Min	Max	Unit
$t_{VDD}$	$V_{DD}$ rise time rate	20	$\infty$	$\mu\text{s/V}$
	$V_{DD}$ fall time rate	20	$\infty$	

### 5.3.4 Operating conditions at power-up / power-down (regulator OFF)

Subject to general operating conditions for  $T_A$ .

**Table 14. Operating conditions at power-up / power-down (regulator OFF)**

Symbol	Parameter	Conditions	Min	Max	Unit
$t_{VDD}$	$V_{DD}$ rise time rate	Power-up	20	$\infty$	$\mu\text{s/V}$
	$V_{DD}$ fall time rate	Power-down	20	$\infty$	
$t_{VCAP}$	$V_{CAP\_1}$ and $V_{CAP\_2}$ rise time rate	Power-up	20	$\infty$	
	$V_{CAP\_1}$ and $V_{CAP\_2}$ fall time rate	Power-down	20	$\infty$	

### 5.3.5 Embedded reset and power control block characteristics

The parameters given in [Table 15](#) are derived from tests performed under ambient temperature and  $V_{DD}$  supply voltage conditions summarized in [Table 10](#).

**Table 15. Embedded reset and power control block characteristics**

Symbol	Parameter	Conditions	Min	Typ	Max	Unit
$V_{PVD}$	Programmable voltage detector level selection	PLS[2:0]=000 (rising edge)	2.09	2.14	2.19	V
		PLS[2:0]=000 (falling edge)	1.98	2.04	2.08	V
		PLS[2:0]=001 (rising edge)	2.23	2.30	2.37	V
		PLS[2:0]=001 (falling edge)	2.13	2.19	2.25	V
		PLS[2:0]=010 (rising edge)	2.39	2.45	2.51	V
		PLS[2:0]=010 (falling edge)	2.29	2.35	2.39	V
		PLS[2:0]=011 (rising edge)	2.54	2.60	2.65	V
		PLS[2:0]=011 (falling edge)	2.44	2.51	2.56	V
		PLS[2:0]=100 (rising edge)	2.70	2.76	2.82	V
		PLS[2:0]=100 (falling edge)	2.59	2.66	2.71	V
		PLS[2:0]=101 (rising edge)	2.86	2.93	2.99	V
		PLS[2:0]=101 (falling edge)	2.65	2.84	3.02	V
		PLS[2:0]=110 (rising edge)	2.96	3.03	3.10	V
		PLS[2:0]=110 (falling edge)	2.85	2.93	2.99	V
		PLS[2:0]=111 (rising edge)	3.07	3.14	3.21	V
PLS[2:0]=111 (falling edge)	2.95	3.03	3.09	V		
$V_{PVDhyst}^{(2)}$	PVD hysteresis		-	100	-	mV
$V_{POR/PDR}$	Power-on/power-down reset threshold	Falling edge	TBD <sup>(1)</sup>	1.70	TBD	V
		Rising edge	TBD	1.74	TBD	V
$V_{PDRhyst}^{(2)}$	PDR hysteresis		-	40	-	mV

**Table 15. Embedded reset and power control block characteristics (continued)**

Symbol	Parameter	Conditions	Min	Typ	Max	Unit
$V_{BOR1}$	Brownout level 1 threshold	Falling edge	2.13	2.19	2.24	V
		Rising edge	2.23	2.29	2.33	V
$V_{BOR2}$	Brownout level 2 threshold	Falling edge	2.44	2.50	2.56	V
		Rising edge	2.53	2.59	2.63	V
$V_{BOR3}$	Brownout level 3 threshold	Falling edge	2.75	2.83	2.88	V
		Rising edge	2.85	2.92	2.97	
$V_{BORhyst}^{(2)}$	BOR hysteresis		-	100	-	mV
$T_{RSTTEMPO}^{(2)(3)}$	Reset temporization		0.5	1.5	3.0	ms
$I_{RUSH}^{(2)}$	InRush current on voltage regulator power-on (POR or wakeup from Standby)		-	160	200	mA
$E_{RUSH}^{(2)}$	InRush energy on voltage regulator power-on (POR or wakeup from Standby)	$V_{DD} = 1.8\text{ V}$ , $T_A = 105\text{ }^\circ\text{C}$ , $I_{RUSH} = 171\text{ mA}$ for $31\text{ }\mu\text{s}$	-	-	5.4	$\mu\text{C}$

1. The product behavior is guaranteed by design down to the minimum  $V_{POR/PDR}$  value.
2. Guaranteed by design, not tested in production.
3. The reset temporization is measured from the power-on (POR reset or wakeup from  $V_{BAT}$ ) to the instant when first instruction is read by the user application code.

### 5.3.6 Supply current characteristics

The current consumption is a function of several parameters and factors such as the operating voltage, ambient temperature, I/O pin loading, device software configuration, operating frequencies, I/O pin switching rate, program location in memory and executed binary code.

The current consumption is measured as described in [Figure 18: Current consumption measurement scheme](#).

All Run mode current consumption measurements given in this section are performed using CoreMark code.

### Typical and maximum current consumption

The MCU is placed under the following conditions:

- At startup, all I/O pins are configured as analog inputs by firmware.
- All peripherals are disabled except if it is explicitly mentioned.
- The Flash memory access time is adjusted to  $f_{HCLK}$  frequency (0 wait state from 0 to 30 MHz, 1 wait state from 30 to 60 MHz, 2 wait states from 60 to 90 MHz and 3 wait states from 90 to 120 MHz).
- When the peripherals are enabled HCLK is the system clock,  $f_{PCLK1} = f_{HCLK}/4$ , and  $f_{PCLK2} = f_{HCLK}/2$ , except is explicitly mentioned.
- The maximum values are obtained for  $V_{DD} = 3.6$  V and maximum ambient temperature ( $T_A$ ), and the typical values for  $T_A = 25$  °C and  $V_{DD} = 3.3$  V unless otherwise specified.

**Table 16. Typical and maximum current consumption in Run mode, code with data processing running from Flash memory (ART accelerator disabled)**

Symbol	Parameter	Conditions	$f_{HCLK}$	Typ	Max <sup>(1)</sup>		Unit
				$T_A = 25$ °C	$T_A = 85$ °C	$T_A = 105$ °C	
$I_{DD}$	Supply current in Run mode	External clock <sup>(2)</sup> , all peripherals enabled <sup>(3)</sup>	120 MHz	61	81	93	mA
			90 MHz	48	68	80	
			60 MHz	33	53	65	
			30 MHz	18	38	50	
			25 MHz	14	34	46	
			16 MHz <sup>(4)</sup>	10	30	42	
			8 MHz	6	26	38	
			4 MHz	4	24	36	
			2 MHz	3	23	35	
		External clock <sup>(3)</sup> , all peripherals disabled	120 MHz	33	54	66	
			90 MHz	27	47	59	
			60 MHz	19	39	51	
			30 MHz	11	31	43	
			25 MHz	8	28	41	
			16 MHz <sup>(4)</sup>	6	26	38	
			8 MHz	4	24	36	
			4 MHz	3	23	35	
			2 MHz	2	23	34	

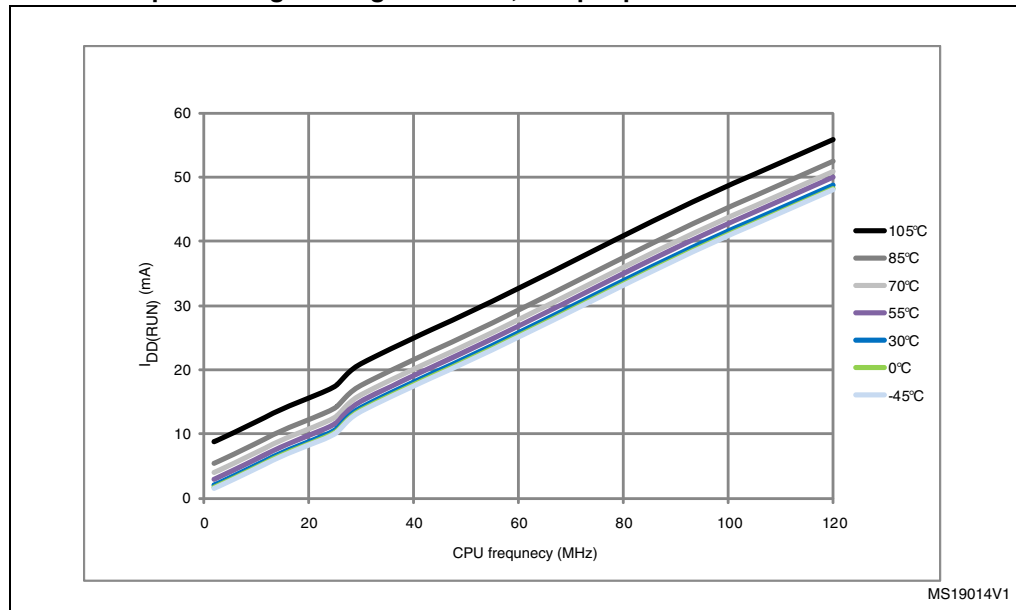
1. Based on characterization, tested in production at  $V_{DD}$  max and  $f_{HCLK}$  max with peripherals enabled.
2. External clock is 4 MHz and PLL is on when  $f_{HCLK} > 25$  MHz.
3. When the ADC is on (ADON bit set in the ADC\_CR2 register), add an additional power consumption of 1.6 mA per ADC for the analog part.
4. In this case HCLK = system clock/2.

**Table 17. Typical and maximum current consumption in Run mode, code with data processing running from Flash memory (ART accelerator enabled) or RAM <sup>(1)</sup>**

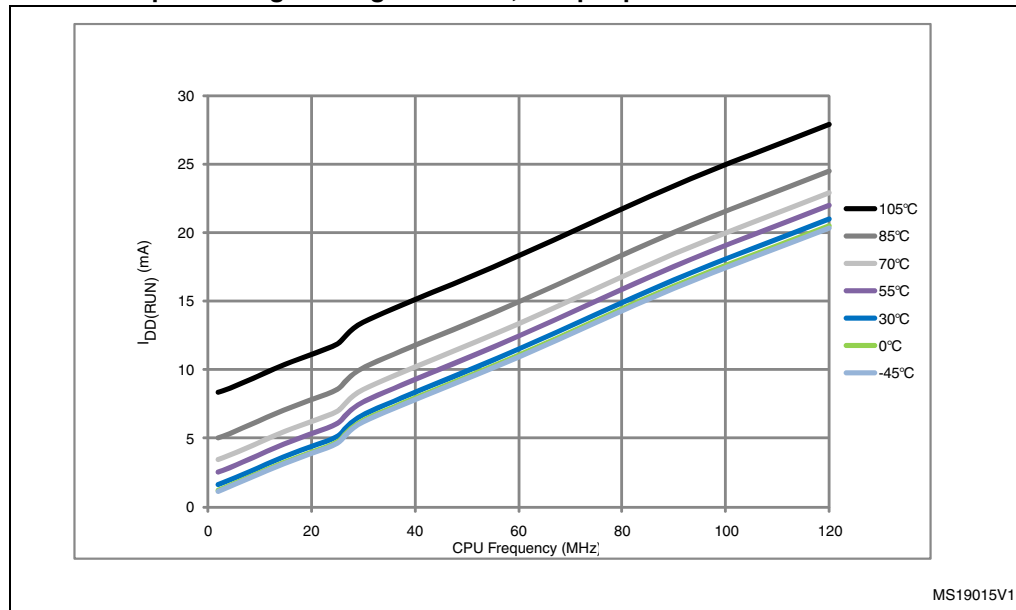
Symbol	Parameter	Conditions	f <sub>HCLK</sub>	Typ	Max <sup>(2)</sup>		Unit
				T <sub>A</sub> = 25 °C	T <sub>A</sub> = 85 °C	T <sub>A</sub> = 105 °C	
I <sub>DD</sub>	Supply current in Run mode	External clock <sup>(3)</sup> , all peripherals enabled <sup>(4)</sup>	120 MHz	49	63	72	mA
			90 MHz	38	51	61	
			60 MHz	26	39	49	
			30 MHz	14	27	37	
			25 MHz	11	24	34	
			16 MHz <sup>(5)</sup>	8	21	30	
			8 MHz	5	17	27	
			4 MHz	3	16	26	
		External clock <sup>(3)</sup> , all peripherals disabled	120 MHz	21	34	44	
			90 MHz	17	30	40	
			60 MHz	12	25	35	
			30 MHz	7	20	30	
			25 MHz	5	18	28	
			16 MHz <sup>(5)</sup>	4.0	17.0	27.0	
			8 MHz	2.5	15.5	25.5	
			4 MHz	2.0	14.7	24.8	
		2 MHz	1.6	14.5	24.6		

- Code and data processing running from SRAM1 using boot pins.
- Based on characterization, tested in production at V<sub>DD</sub> max and f<sub>HCLK</sub> max with peripherals enabled.
- External clock is 4 MHz and PLL is on when f<sub>HCLK</sub> > 25 MHz.
- When the ADC is on (ADON bit set in the ADC\_CR2 register), add an additional power consumption of 1.6 mA per ADC for the analog part.
- In this case HCLK = system clock/2.

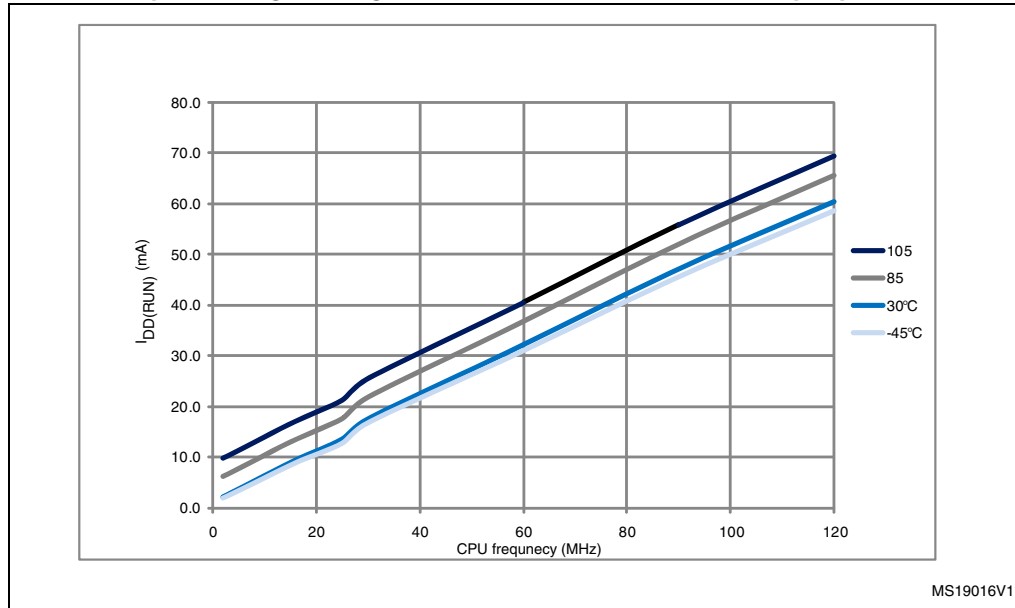
**Figure 21. Typical current consumption vs temperature, Run mode, code with data processing running from RAM, and peripherals ON**



**Figure 22. Typical current consumption vs temperature, Run mode, code with data processing running from RAM, and peripherals OFF**



**Figure 23. Typical current consumption vs temperature, Run mode, code with data processing running from Flash, ART accelerator OFF, peripherals ON**



**Figure 24. Typical current consumption vs temperature, Run mode, code with data processing running from Flash, ART accelerator OFF, peripherals OFF**

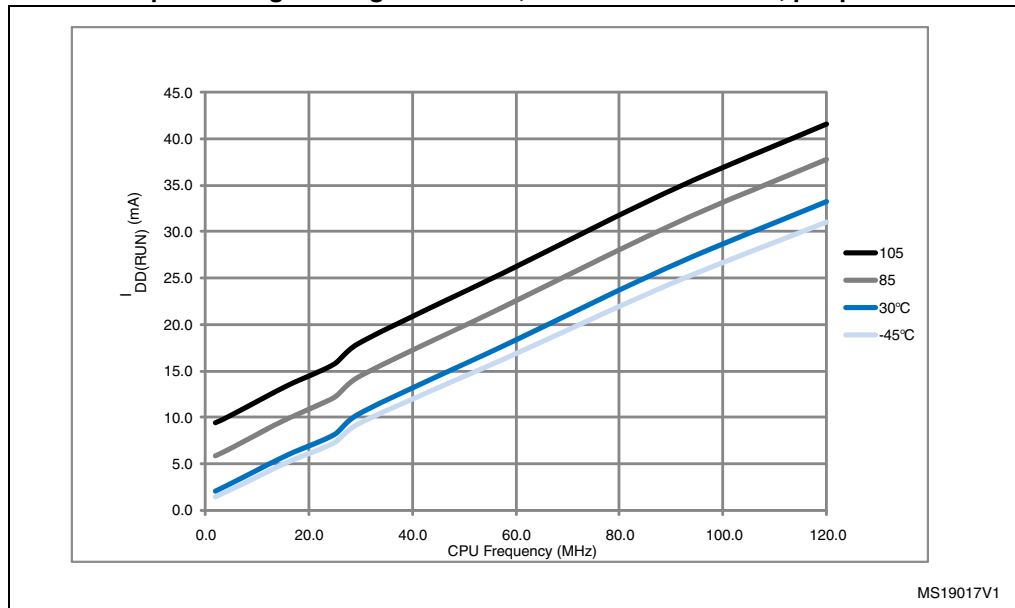


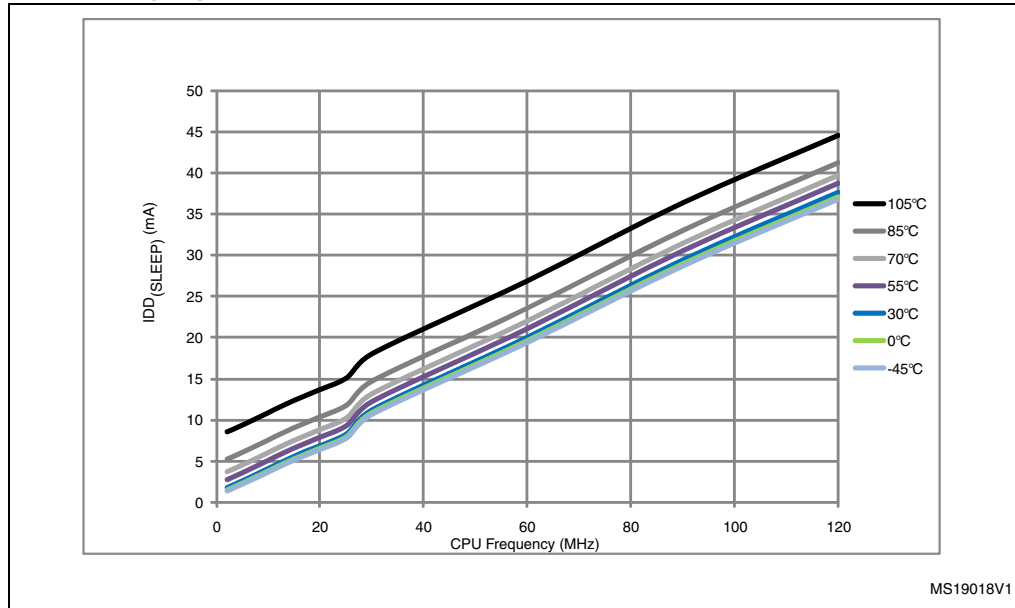
Table 18. Typical and maximum current consumption in Sleep mode

Symbol	Parameter	Conditions	f <sub>HCLK</sub>	Typ	Max <sup>(1)</sup>		Unit
				T <sub>A</sub> = 25 °C	T <sub>A</sub> = 85 °C	T <sub>A</sub> = 105 °C	
I <sub>DD</sub>	Supply current in Sleep mode	External clock <sup>(2)</sup> , all peripherals enabled <sup>(3)</sup>	120 MHz	38	51	61	mA
			90 MHz	30	43	53	
			60 MHz	20	33	43	
			30 MHz	11	25	35	
			25 MHz	8	21	31	
			16 MHz	6	19	29	
			8 MHz	3.6	17.0	27.0	
			4 MHz	2.4	15.4	25.3	
		2 MHz	1.9	14.9	24.7		
		External clock <sup>(2)</sup> , all peripherals disabled	120 MHz	8	21	31	
			90 MHz	7	20	30	
			60 MHz	5	18	28	
			30 MHz	3.5	16.0	26.0	
			25 MHz	2.5	16.0	25.0	
			16 MHz	2.1	15.1	25.0	
			8 MHz	1.7	15.0	25.0	
4 MHz	1.5		14.6	24.6			
2 MHz	1.4	14.2	24.3				

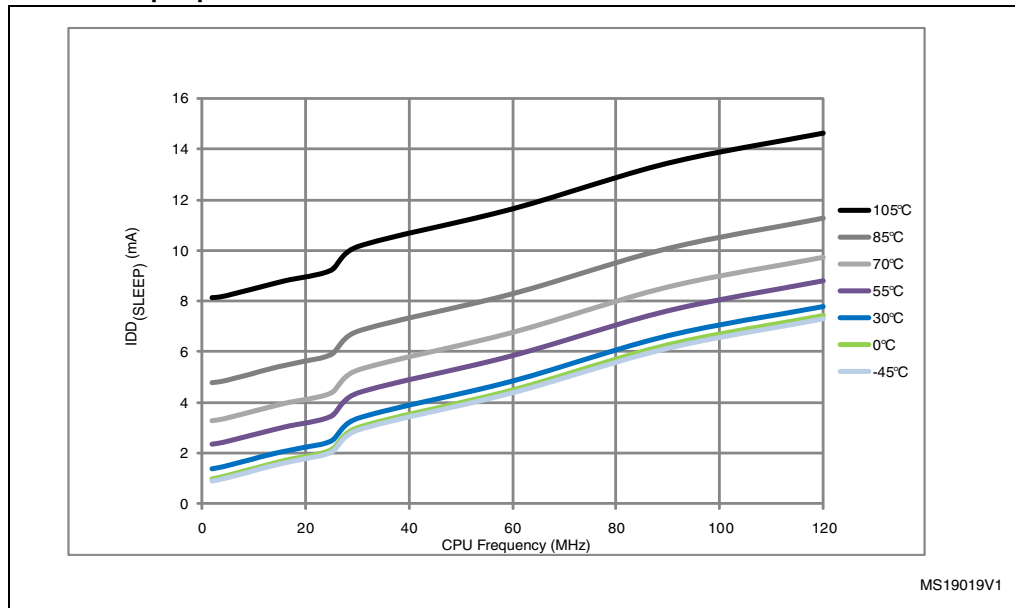
1. Based on characterization, tested in production at V<sub>DD</sub> max and f<sub>HCLK</sub> max with peripherals enabled.
2. External clock is 4 MHz and PLL is on when f<sub>HCLK</sub> > 25 MHz.
3. Add an additional power consumption of 0.8 mA per ADC for the analog part. In applications, this consumption occurs only while the ADC is on (ADON bit is set in the ADC\_CR2 register).



**Figure 25. Typical current consumption vs temperature in Sleep mode, peripherals ON**



**Figure 26. Typical current consumption vs temperature in Sleep mode, peripherals OFF**

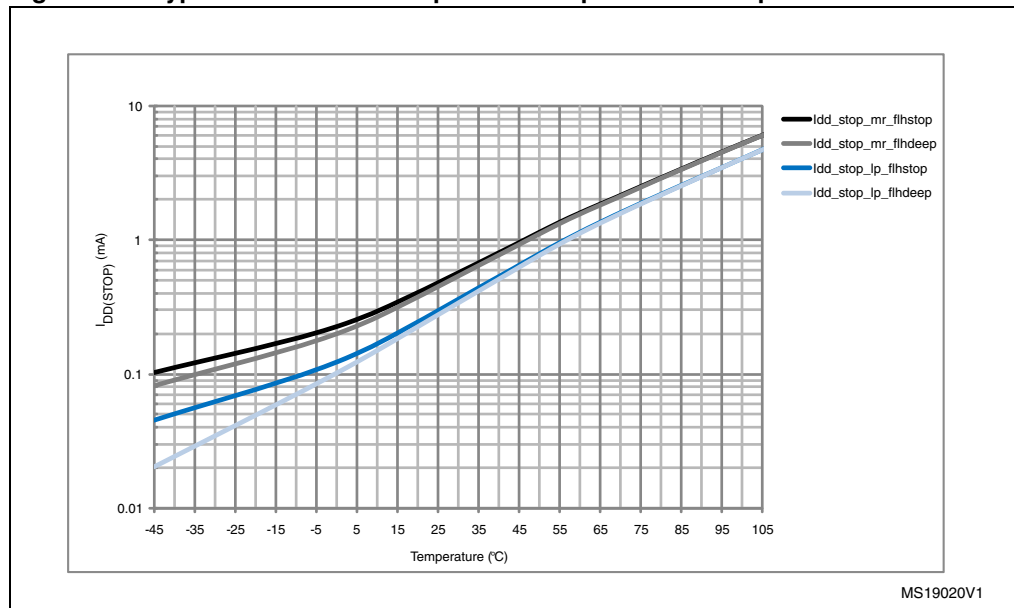


**Table 19. Typical and maximum current consumptions in Stop mode<sup>(1)</sup>**

Symbol	Parameter	Conditions	Typ		Max		Unit
			T <sub>A</sub> = 25 °C	T <sub>A</sub> = 25 °C	T <sub>A</sub> = 85 °C	T <sub>A</sub> = 105 °C	
I <sub>DD_STOP</sub>	Supply current in Stop mode with main regulator in Run mode	Flash in Stop mode, low-speed and high-speed internal RC oscillators and high-speed oscillator OFF (no independent watchdog)	0.55	1.2	11.00	20.00	mA
		Flash in Deep power down mode, low-speed and high-speed internal RC oscillators and high-speed oscillator OFF (no independent watchdog)	0.50	1.2	11.00	20.00	
	Supply current in Stop mode with main regulator in Low Power mode	Flash in Stop mode, low-speed and high-speed internal RC oscillators and high-speed oscillator OFF (no independent watchdog)	0.35	1.1	8.00	15.00	
		Flash in Deep power down mode, low-speed and high-speed internal RC oscillators and high-speed oscillator OFF (no independent watchdog)	0.30	1.1	8.00	15.00	

1. All typical and maximum values will be further reduced by up to 50% as part of ST continuous improvement of test procedures. New versions of the datasheet will be released to reflect these changes.

**Figure 27. Typical current consumption vs temperature in Stop mode**



1. All typical and maximum values from table 18 and figure 26 will be reduced over time by up to 50% as part of ST continuous improvement of test procedures. New versions of the datasheet will be released to reflect these changes

**Table 20. Typical and maximum current consumptions in Standby mode**

Symbol	Parameter	Conditions	Typ			Max		Unit
			T <sub>A</sub> = 25 °C			T <sub>A</sub> = 85 °C	T <sub>A</sub> = 105 °C	
			V <sub>DD</sub> = 1.8 V	V <sub>DD</sub> = 2.4 V	V <sub>DD</sub> = 3.3 V	V <sub>DD</sub> = 3.6 V		
I <sub>DD_STBY</sub>	Supply current in Standby mode	Backup SRAM ON, RTC ON	4.8	5.2	5.8	15.1 <sup>(1)</sup>	25.8 <sup>(1)</sup>	μA
		Backup SRAM OFF, RTC ON	4.2	4.5	5.1	12.4 <sup>(1)</sup>	20.5 <sup>(1)</sup>	
		Backup SRAM ON, RTC OFF	2.3	2.5	3.2	12.5 <sup>(1)</sup>	24.8 <sup>(1)</sup>	
		Backup SRAM OFF, RTC OFF	1.6	1.8	2.5	9.8 <sup>(1)</sup>	19.2 <sup>(1)</sup>	

1. Based on characterization, not tested in production.

**Table 21. Typical and maximum current consumptions in V<sub>BAT</sub> mode**

Symbol	Parameter	Conditions	Typ			Max		Unit
			T <sub>A</sub> = 25 °C			T <sub>A</sub> = 85 °C	T <sub>A</sub> = 105 °C	
			V <sub>DD</sub> = 1.8 V	V <sub>DD</sub> = 2.4 V	V <sub>DD</sub> = 3.3 V	V <sub>DD</sub> = 3.6 V		
I <sub>DD_VBAT</sub>	Backup domain supply current	Backup SRAM ON, RTC ON	3.2	3.4	3.7	12 <sup>(1)</sup>	19 <sup>(1)</sup>	μA
		Backup SRAM OFF, low-speed oscillator and RTC ON	2.6	2.7	3.0	8 <sup>(1)</sup>	10 <sup>(1)</sup>	
		Backup SRAM ON, RTC OFF	0.7	0.7	0.8	9 <sup>(1)</sup>	16 <sup>(1)</sup>	
		Backup SRAM OFF, RTC OFF	0.1	0.1	0.1	5 <sup>(1)</sup>	7 <sup>(1)</sup>	

1. Based on characterization, not tested in production.

### On-chip peripheral current consumption

The current consumption of the on-chip peripherals is given in [Table 22](#). The MCU is placed under the following conditions:

- At startup, all I/O pins are configured as analog inputs by firmware.
- All peripherals are disabled unless otherwise mentioned
- The given value is calculated by measuring the current consumption
  - with all peripherals clocked off
  - with one peripheral clocked on (with only the clock applied)
- The code is running from Flash memory and the Flash memory access time is equal to 3 wait states at 120 MHz
- Prefetch and Cache ON
- When the peripherals are enabled, HCLK = 120MHz, f<sub>PCLK1</sub> = f<sub>HCLK</sub>/4, and f<sub>PCLK2</sub> = f<sub>HCLK</sub>/2
- The typical values are obtained for V<sub>DD</sub> = 3.3 V and T<sub>A</sub> = 25 °C, unless otherwise specified.

Table 22. Peripheral current consumption

Peripheral <sup>(1)</sup>		Typical consumption at 25 °C	Unit
AHB1	GPIO A	0.45	mA
	GPIO B	0.43	
	GPIO C	0.46	
	GPIO D	0.44	
	GPIO E	0.44	
	GPIO F	0.42	
	GPIO G	0.44	
	GPIO H	0.42	
	GPIO I	0.43	
	OTG_HS + ULPI	3.64	
	CRC	1.17	
	BKPSRAM	0.21	
	DMA1	2.76	
	DMA2	2.85	
ETH_MAC + ETH_MAC_TX ETH_MAC_RX ETH_MAC_PTP	2.99		
AHB2	OTG_FS	3.16	mA
	DCMI	0.60	
AHB3	FSMC	1.74	mA
AHB2	CRYPTO	0.39	
	HASH	0.50	
	RNG	0.43	

Table 22. Peripheral current consumption (continued)

Peripheral <sup>(1)</sup>		Typical consumption at 25 °C	Unit
APB1	TIM2	0.61	mA
	TIM3	0.49	
	TIM4	0.54	
	TIM5	0.62	
	TIM6	0.20	
	TIM7	0.20	
	TIM12	0.36	
	TIM13	0.28	
	TIM14	0.25	
	USART2	0.25	
	USART3	0.25	
	UART4	0.25	
	UART5	0.26	
	I2C1	0.25	
	I2C2	0.25	
	I2C3	0.25	
	SPI2	0.20/0.10	
	SPI3	0.18/0.09	
	CAN1	0.31	
	CAN2	0.30	
	DAC channel 1 <sup>(2)</sup>	1.11	
	DAC channel 1 <sup>(3)</sup>	1.11	
PWR	0.15		
WWDG	0.15		

**Table 22. Peripheral current consumption (continued)**

Peripheral <sup>(1)</sup>		Typical consumption at 25 °C	Unit
APB2	SDIO	0.69	mA
	TIM1	1.06	
	TIM8	1.03	
	TIM9	0.58	
	TIM10	0.37	
	TIM11	0.39	
	ADC1 <sup>(4)</sup>	2.13	
	ADC2 <sup>(4)</sup>	2.04	
	ADC3 <sup>(4)</sup>	2.12	
	SPI1	1.20	
	USART1	0.38	
	USART6	0.37	

- External clock is 25 MHz (HSE oscillator with 25 MHz crystal) and PLL is on.
- EN1 bit is set in DAC\_CR register.
- EN2 bit is set in DAC\_CR register.
- $f_{ADC} = f_{PCLK2}/2$ , ADON bit set in ADC\_CR2 register.

### 5.3.7 Wakeup time from low-power mode

The wakeup times given in [Table 23](#) is measured on a wakeup phase with a 16 MHz HSI RC oscillator. The clock source used to wake up the device depends from the current operating mode:

- Stop or Standby mode: the clock source is the RC oscillator
- Sleep mode: the clock source is the clock that was set before entering Sleep mode.

All timings are derived from tests performed under ambient temperature and  $V_{DD}$  supply voltage conditions summarized in [Table 10](#).

**Table 23. Low-power mode wakeup timings**

Symbol	Parameter	Min <sup>(1)</sup>	Typ <sup>(1)</sup>	Max <sup>(1)</sup>	Unit
$t_{WUSLEEP}^{(2)}$	Wakeup from Sleep mode	-	1	-	µs
$t_{WUSTOP}^{(2)}$	Wakeup from Stop mode (regulator in Run mode)	-	13	-	µs
	Wakeup from Stop mode (regulator in low power mode)	-	17	40	
	Wakeup from Stop mode (regulator in low power mode and Flash memory in Deep power down mode)	-	110	-	
$t_{WUSTDBY}^{(2)(3)}$	Wakeup from Standby mode	260	375	480	µs

- Based on characterization, not tested in production.
- The wakeup times are measured from the wakeup event to the point in which the application code reads the first instruction.
- $t_{WUSTDBY}$  minimum and maximum values are given at 105 °C and -45 °C, respectively.

### 5.3.8 External clock source characteristics

#### High-speed external user clock generated from an external source

The characteristics given in [Table 24](#) result from tests performed using an high-speed external clock source, and under ambient temperature and supply voltage conditions summarized in [Table 10](#).

**Table 24. High-speed external user clock characteristics**

Symbol	Parameter	Conditions	Min	Typ	Max	Unit
$f_{\text{HSE\_ext}}$	External user clock source frequency <sup>(1)</sup>		1	8	26	MHz
$V_{\text{HSEH}}$	OSC_IN input pin high level voltage		$0.7V_{\text{DD}}$	-	$V_{\text{DD}}$	V
$V_{\text{HSEL}}$	OSC_IN input pin low level voltage		$V_{\text{SS}}$	-	$0.3V_{\text{DD}}$	
$t_{\text{w(HSE)}}$ $t_{\text{f(HSE)}}$	OSC_IN high or low time <sup>(1)</sup>		5	-	-	ns
$t_{\text{r(HSE)}}$ $t_{\text{f(HSE)}}$	OSC_IN rise or fall time <sup>(1)</sup>		-	-	20	
$C_{\text{in(HSE)}}$	OSC_IN input capacitance <sup>(1)</sup>		-	5	-	pF
$\text{DuCy}_{(\text{HSE})}$	Duty cycle		45	-	55	%
$I_{\text{L}}$	OSC_IN Input leakage current	$V_{\text{SS}} \leq V_{\text{IN}} \leq V_{\text{DD}}$	-	-	$\pm 1$	$\mu\text{A}$

1. Guaranteed by design, not tested in production.

#### Low-speed external user clock generated from an external source

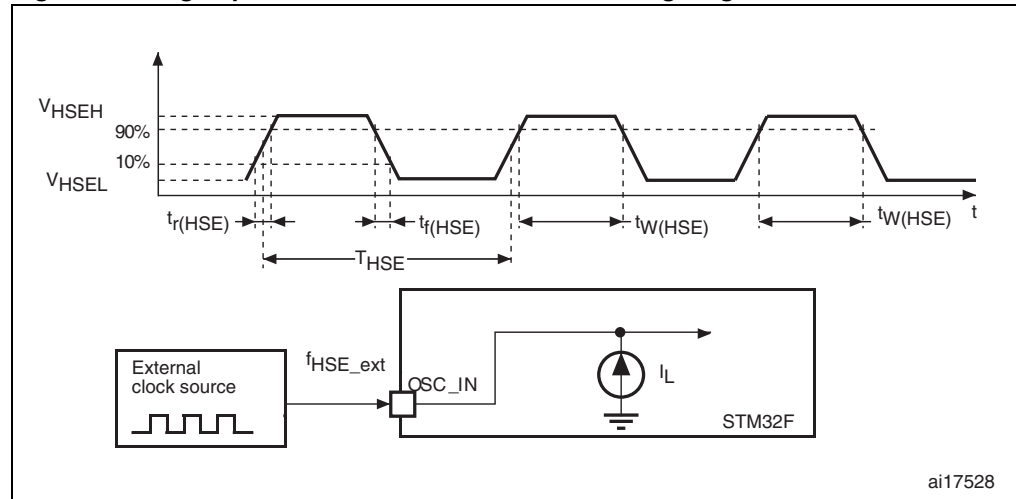
The characteristics given in [Table 25](#) result from tests performed using an low-speed external clock source, and under ambient temperature and supply voltage conditions summarized in [Table 10](#).

**Table 25. Low-speed external user clock characteristics**

Symbol	Parameter	Conditions	Min	Typ	Max	Unit
$f_{\text{LSE\_ext}}$	User External clock source frequency <sup>(1)</sup>		-	32.768	1000	kHz
$V_{\text{LSEH}}$	OSC32_IN input pin high level voltage		$0.7V_{\text{DD}}$	-	$V_{\text{DD}}$	V
$V_{\text{LSEL}}$	OSC32_IN input pin low level voltage		$V_{\text{SS}}$	-	$0.3V_{\text{DD}}$	
$t_{\text{w(LSE)}}$ $t_{\text{f(LSE)}}$	OSC32_IN high or low time <sup>(1)</sup>		450	-	-	ns
$t_{\text{r(LSE)}}$ $t_{\text{f(LSE)}}$	OSC32_IN rise or fall time <sup>(1)</sup>		-	-	50	
$C_{\text{in(LSE)}}$	OSC32_IN input capacitance <sup>(1)</sup>		-	5	-	pF
$\text{DuCy}_{(\text{LSE})}$	Duty cycle		30	-	70	%
$I_{\text{L}}$	OSC32_IN Input leakage current	$V_{\text{SS}} \leq V_{\text{IN}} \leq V_{\text{DD}}$	-	-	$\pm 1$	$\mu\text{A}$

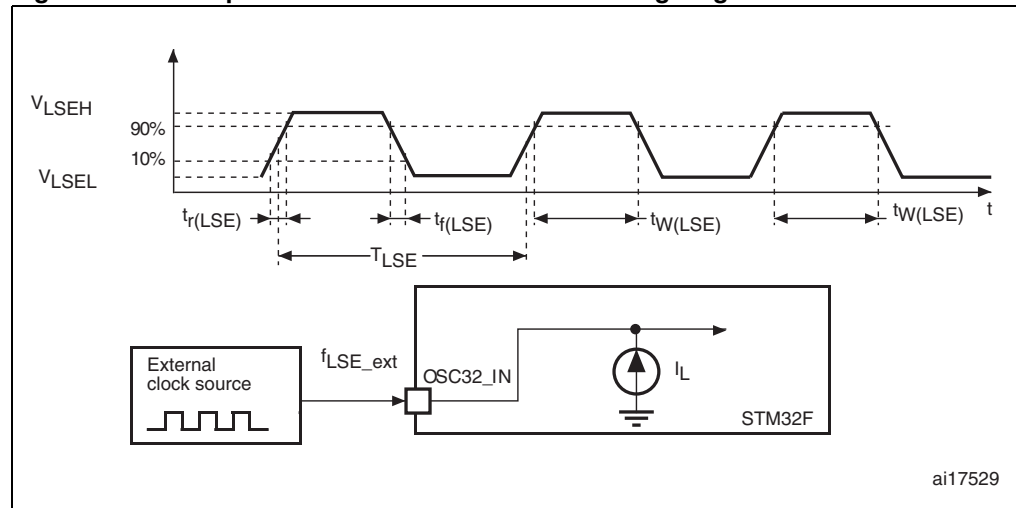
1. Guaranteed by design, not tested in production.

Figure 28. High-speed external clock source AC timing diagram



ai17528

Figure 29. Low-speed external clock source AC timing diagram



ai17529

### High-speed external clock generated from a crystal/ceramic resonator

The high-speed external (HSE) clock can be supplied with a 4 to 26 MHz crystal/ceramic resonator oscillator. All the information given in this paragraph are based on characterization results obtained with typical external components specified in [Table 26](#). In the application, the resonator and the load capacitors have to be placed as close as possible to the oscillator pins in order to minimize output distortion and startup stabilization time. Refer to the crystal resonator manufacturer for more details on the resonator characteristics (frequency, package, accuracy).

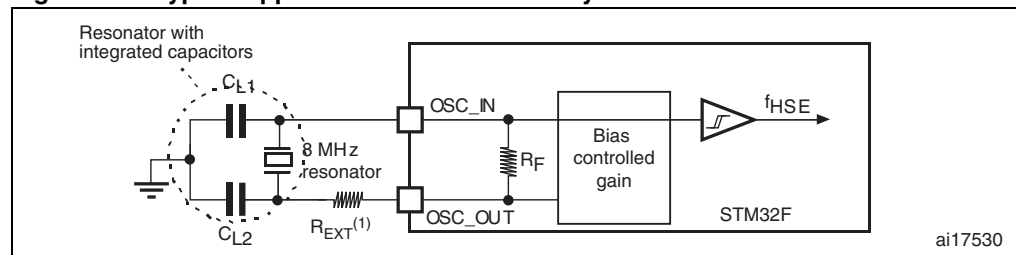


**Table 26. HSE 4-26 MHz oscillator characteristics<sup>(1) (2)</sup>**

Symbol	Parameter	Conditions	Min	Typ	Max	Unit
$f_{OSC\_IN}$	Oscillator frequency		4	-	26	MHz
$R_F$	Feedback resistor		-	200	-	k $\Omega$
C	Recommended load capacitance versus equivalent serial resistance of the crystal ( $R_S$ ) <sup>(3)</sup>	$R_S = 30 \Omega$	-	15	-	pF
$i_2$	HSE driving current	$V_{DD} = 3.3 V, V_{IN} = V_{SS}$ with 30 pF load	-	-	1	mA
$g_m$	Oscillator transconductance	Startup	5	-	-	mA/V
$t_{SU(HSE)}$ <sup>(4)</sup>	Startup time	$V_{DD}$ is stabilized	-	2	-	ms

1. Resonator characteristics given by the crystal/ceramic resonator manufacturer.
2. Based on characterization, not tested in production.
3. The relatively low value of the RF resistor offers a good protection against issues resulting from use in a humid environment, due to the induced leakage and the bias condition change. However, it is recommended to take this point into account if the MCU is used in tough humidity conditions.
4.  $t_{SU(HSE)}$  is the startup time measured from the moment it is enabled (by software) to a stabilized 8 MHz oscillation is reached. This value is measured for a standard crystal resonator and it can vary significantly with the crystal manufacturer

For  $C_{L1}$  and  $C_{L2}$ , it is recommended to use high-quality external ceramic capacitors in the 5 pF to 25 pF range (typ.), designed for high-frequency applications, and selected to match the requirements of the crystal or resonator (see [Figure 30](#)).  $C_{L1}$  and  $C_{L2}$  are usually the same size. The crystal manufacturer typically specifies a load capacitance which is the series combination of  $C_{L1}$  and  $C_{L2}$ . PCB and MCU pin capacitance must be included (10 pF can be used as a rough estimate of the combined pin and board capacitance) when sizing  $C_{L1}$  and  $C_{L2}$ . Refer to the application note AN2867 "Oscillator design guide for ST microcontrollers" available from the ST website [www.st.com](http://www.st.com).

**Figure 30. Typical application with an 8 MHz crystal**

1.  $R_{EXT}$  value depends on the crystal characteristics.

### Low-speed external clock generated from a crystal/ceramic resonator

The low-speed external (LSE) clock can be supplied with a 32.768 kHz crystal/ceramic resonator oscillator. All the information given in this paragraph are based on characterization results obtained with typical external components specified in [Table 27](#). In the application, the resonator and the load capacitors have to be placed as close as possible to the oscillator pins in order to minimize output distortion and startup stabilization time. Refer to the crystal resonator manufacturer for more details on the resonator characteristics (frequency, package, accuracy).

**Table 27. LSE oscillator characteristics ( $f_{LSE} = 32.768 \text{ kHz}$ ) <sup>(1)</sup>**

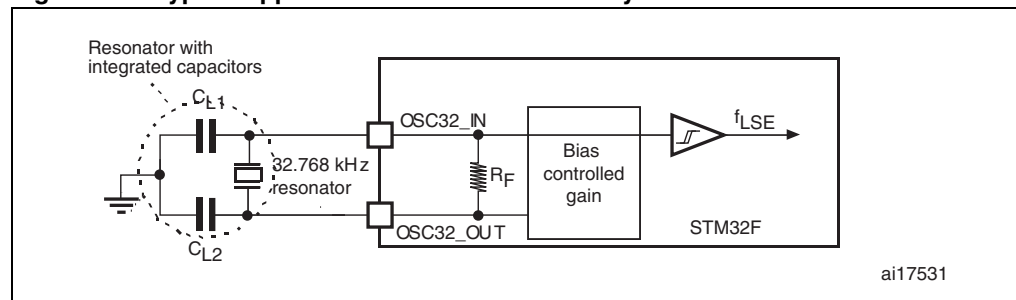
Symbol	Parameter	Conditions	Min	Typ	Max	Unit
$R_F$	Feedback resistor		-	18.4	-	M $\Omega$
$C^{(2)}$	Recommended load capacitance versus equivalent serial resistance of the crystal ( $R_S$ ) <sup>(3)</sup>	$R_S = 30 \text{ k}\Omega$	-	-	15	pF
$I_2$	LSE driving current	$V_{DD} = 3.3 \text{ V}, V_{IN} = V_{SS}$	-	-	3.5	$\mu\text{A}$
$g_m$	Oscillator Transconductance		7	-	-	$\mu\text{A/V}$
$t_{SU(LSE)}$ <sup>(4)</sup>	startup time	$V_{DD}$ is stabilized	-	2	-	s

1. Based on characterization, not tested in production.
2. Refer to the note and caution paragraphs below the table, and to the application note AN2867 "Oscillator design guide for ST microcontrollers".
3. The oscillator selection can be optimized in terms of supply current using an high quality resonator with small  $R_S$  value for example MSIV-TIN32.768kHz. Refer to crystal manufacturer for more details
4.  $t_{SU(LSE)}$  is the startup time measured from the moment it is enabled (by software) to a stabilized 32.768 kHz oscillation is reached. This value is measured for a standard crystal resonator and it can vary significantly with the crystal manufacturer

**Note:** For  $C_{L1}$  and  $C_{L2}$  it is recommended to use high-quality external ceramic capacitors in the 5 pF to 15 pF range selected to match the requirements of the crystal or resonator (see [Figure 31](#)).  $C_{L1}$  and  $C_{L2}$  are usually the same size. The crystal manufacturer typically specifies a load capacitance which is the series combination of  $C_{L1}$  and  $C_{L2}$ . Load capacitance  $C_L$  has the following formula:  $C_L = C_{L1} \times C_{L2} / (C_{L1} + C_{L2}) + C_{stray}$  where  $C_{stray}$  is the pin capacitance and board or trace PCB-related capacitance. Typically, it is between 2 pF and 7 pF.

**Caution:** To avoid exceeding the maximum value of  $C_{L1}$  and  $C_{L2}$  (15 pF) it is strongly recommended to use a resonator with a load capacitance  $C_L \leq 7 \text{ pF}$ . Never use a resonator with a load capacitance of 12.5 pF.

**Example:** if you choose a resonator with a load capacitance of  $C_L = 6 \text{ pF}$ , and  $C_{stray} = 2 \text{ pF}$ , then  $C_{L1} = C_{L2} = 8 \text{ pF}$ .

**Figure 31. Typical application with a 32.768 kHz crystal**

### 5.3.9 Internal clock source characteristics

The parameters given in [Table 28](#) and [Table 29](#) are derived from tests performed under ambient temperature and  $V_{DD}$  supply voltage conditions summarized in [Table 10](#).

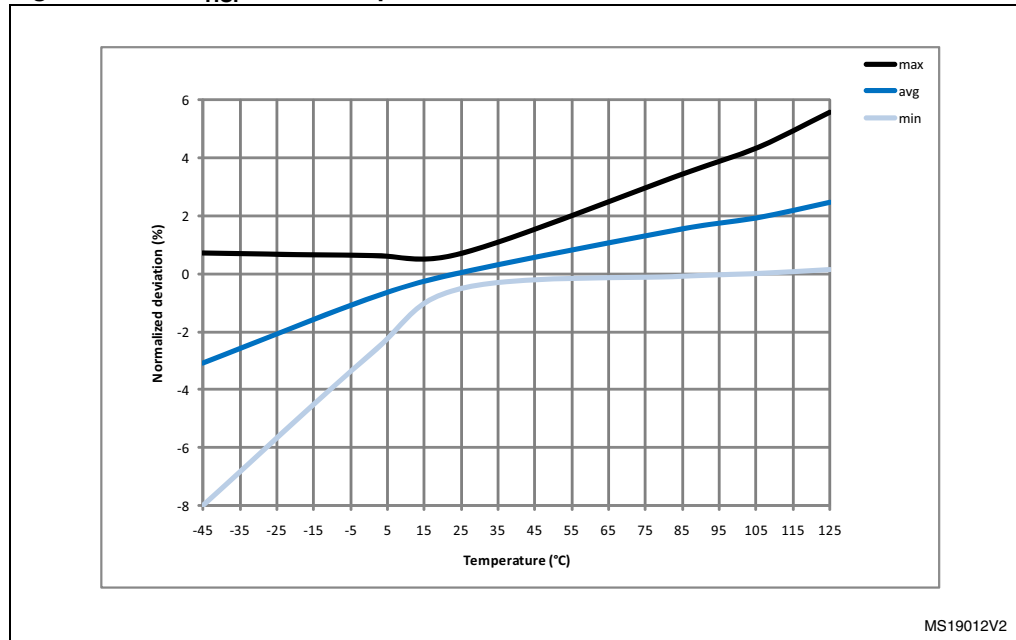
#### High-speed internal (HSI) RC oscillator

**Table 28. HSI oscillator characteristics <sup>(1)</sup>**

Symbol	Parameter	Conditions	Min	Typ	Max	Unit	
$f_{HSI}$	Frequency		-	16	-	MHz	
$ACC_{HSI}$	Accuracy of the HSI oscillator	User-trimmed with the RCC_CR register <sup>(2)</sup>	-	-	1	%	
		Factory-calibrated	$T_A = -40$ to $105$ °C	-8	-	4.5	%
			$T_A = -10$ to $85$ °C	-4	-	4	%
			$T_A = 25$ °C	-1	-	1	%
$t_{su(HSI)}$ <sup>(3)</sup>	HSI oscillator startup time		-	2.2	4	$\mu$ s	
$I_{DD(HSI)}$	HSI oscillator power consumption		-	60	80	$\mu$ A	

- $V_{DD} = 3.3$  V,  $T_A = -40$  to  $105$  °C unless otherwise specified.
- Refer to application note AN2868 "STM32F10xxx internal RC oscillator (HSI) calibration" available from the ST website [www.st.com](http://www.st.com).
- Guaranteed by design, not tested in production.

**Figure 32.  $ACC_{HSI}$  versus temperature**



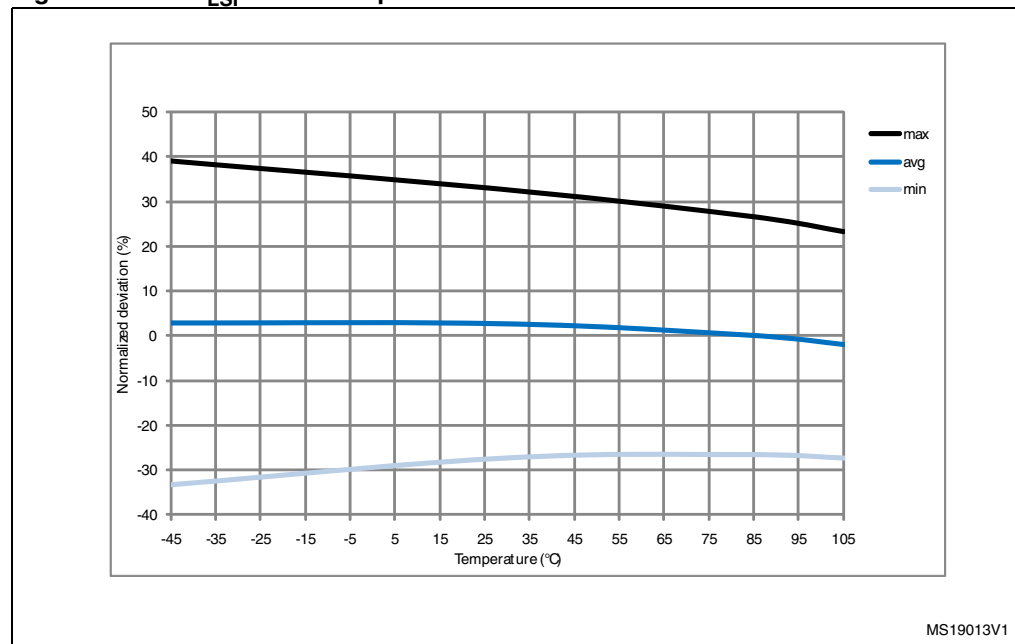
### Low-speed internal (LSI) RC oscillator

**Table 29. LSI oscillator characteristics (1)**

Symbol	Parameter	Min	Typ	Max	Unit
$f_{LSI}^{(2)}$	Frequency	17	32	47	kHz
$t_{su(LSI)}^{(3)}$	LSI oscillator startup time	-	15	40	$\mu$ s
$I_{DD(LSI)}^{(3)}$	LSI oscillator power consumption	-	0.4	0.6	$\mu$ A

- $V_{DD} = 3$  V,  $T_A = -40$  to  $105$  °C unless otherwise specified.
- Based on characterization, not tested in production.
- Guaranteed by design, not tested in production.

**Figure 33.  $ACC_{LSI}$  versus temperature**



### 5.3.10 PLL characteristics

The parameters given in [Table 30](#) and [Table 31](#) are derived from tests performed under temperature and  $V_{DD}$  supply voltage conditions summarized in [Table 10](#).

**Table 30. Main PLL characteristics**

Symbol	Parameter	Conditions	Min	Typ	Max	Unit
$f_{PLL\_IN}$	PLL input clock <sup>(1)</sup>		0.95 (2)	1	2.10 <sup>(2)</sup>	MHz
$f_{PLL\_OUT}$	PLL multiplier output clock		24	-	120	MHz
$f_{PLL48\_OUT}$	48 MHz PLL multiplier output clock		-	-	48	MHz
$f_{VCO\_OUT}$	PLL VCO output		192	-	432	MHz

Table 30. Main PLL characteristics (continued)

Symbol	Parameter	Conditions	Min	Typ	Max	Unit	
$t_{\text{LOCK}}$	PLL lock time	VCO freq = 192 MHz	75	-	200	$\mu\text{s}$	
		VCO freq = 432 MHz	100	-	300		
Jitter <sup>(3)</sup>	Cycle-to-cycle jitter	System clock 120 MHz	RMS	-	25	-	ps
			peak to peak	-	$\pm 150$	-	
	RMS		-	15	-		
	peak to peak		-	$\pm 200$	-		
	Period Jitter						
	Main clock output (MCO) for RMII Ethernet	Cycle to cycle at 50 MHz on 1000 samples	-	32	-		
	Main clock output (MCO) for MII Ethernet	Cycle to cycle at 25 MHz on 1000 samples	-	40	-		
Bit Time CAN jitter	Cycle to cycle at 1 MHz on 1000 samples	-	330	-			
$I_{\text{DD(PLL)}}^{(4)}$	PLL power consumption on VDD	VCO freq = 192 MHz	0.15	-	0.40	mA	
		VCO freq = 432 MHz	0.45	-	0.75		
$I_{\text{DDA(PLL)}}^{(4)}$	PLL power consumption on VDDA	VCO freq = 192 MHz VCO freq = 432 MHz	0.30 0.55	-	0.40 0.85	mA	

1. Take care of using the appropriate division factor M to obtain the specified PLL input clock values. The M factor is shared between PLL and PLLI2S.
2. Guaranteed by design, not tested in production.
3. The use of 2 PLLs in parallel could degraded the Jitter up to +30%.
4. Based on characterization, not tested in production.

Table 31. PLLI2S (audio PLL) characteristics<sup>(1)</sup>

Symbol	Parameter	Conditions	Min	Typ	Max	Unit
$f_{\text{PLLI2S\_IN}}$	PLLI2S input clock <sup>(2)</sup>		0.95 <sup>(3)</sup>	1	2.10 <sup>(3)</sup>	MHz
$f_{\text{PLLI2S\_OUT}}$	PLLI2S multiplier output clock		-	-	216	MHz
$f_{\text{VCO\_OUT}}$	PLLI2S VCO output		192	-	432	MHz
$t_{\text{LOCK}}$	PLLI2S lock time	VCO freq = 192 MHz	75	-	200	$\mu\text{s}$
		VCO freq = 432 MHz	100	-	300	

Table 31. PLLI2S (audio PLL) characteristics<sup>(1)</sup> (continued)

Symbol	Parameter	Conditions	Min	Typ	Max	Unit	
Jitter <sup>(4)</sup>	Master I2S clock jitter	Cycle to cycle at 12,343 MHz on 48KHz period, N=432, P=4, R=5	RMS	-	90	-	
			peak to peak	-	±280	-	ps
		Average frequency of 12,343 MHz N=432, P=4, R=5 on 256 samples	TBD	-	TBD	ps	
	WS I2S clock jitter	Cycle to cycle at 48 KHz on 1000 samples	-	400	-	ps	
$I_{DD(PLLI2S)}$ <sup>(5)</sup>	PLLI2S power consumption on $V_{DD}$	VCO freq = 192 MHz VCO freq = 432 MHz	0.15 0.45	-	0.40 0.75	mA	
$I_{DDA(PLLI2S)}$ <sup>(5)</sup>	PLLI2S power consumption on $V_{DDA}$	VCO freq = 192 MHz VCO freq = 432 MHz	0.30 0.55	-	0.40 0.85	mA	

1. TBD stands for "to be defined".
2. Take care of using the appropriate division factor M to have the specified PLL input clock values.
3. Guaranteed by design, not tested in production.
4. Value given with main PLL running.
5. Based on characterization, not tested in production.

### 5.3.11 PLL spread spectrum clock generation (SSCG) characteristics

The spread spectrum clock generation (SSCG) feature allows to reduce electromagnetic interferences (see [Table 38: EMI characteristics](#)). It is available only on the main PLL.

**Table 32. SSCG parameters constraint**

Symbol	Parameter	Min	Typ	Max <sup>(1)</sup>	Unit
f <sub>Mod</sub>	Modulation frequency	-	-	10	KHz
md	Peak modulation depth	0.25	-	2	%
MODEPER * INCSTEP		-	-	2 <sup>15</sup> -1	-

1. Guaranteed by design, not tested in production.

#### Equation 1

The frequency modulation period (MODEPER) is given by the equation below:

$$\text{MODEPER} = \text{round}[f_{\text{PLL\_IN}} / (4 \times f_{\text{Mod}})]$$

f<sub>PLL\_IN</sub> and f<sub>Mod</sub> must be expressed in Hz.

As an example:

If f<sub>PLL\_IN</sub> = 1 MHz and f<sub>MOD</sub> = 1 kHz, the modulation depth (MODEPER) is given by equation 1:

$$\text{MODEPER} = \text{round}[10^6 / (4 \times 10^3)] = 25$$

#### Equation 2

Equation 2 allows to calculate the increment step (INCSTEP):

$$\text{INCSTEP} = \text{round}[(2^{15} - 1) \times \text{md} \times f_{\text{VCO\_OUT}} / (100 \times 5 \times \text{MODEPER})]$$

f<sub>VCO\_OUT</sub> must be expressed in MHz.

With a modulation depth (md) = ±2 % (4 % peak to peak), and f<sub>VCO\_OUT</sub> = 240 (in MHz):

$$\text{INCSTEP} = \text{round}[(2^{15} - 1) \times 2 \times 240 / (100 \times 5 \times 25)] = 1258 \text{md}(\text{quantitized})\%$$

An amplitude quantization error may be generated because the linear modulation profile is obtained by taking the quantized values (rounded to the nearest integer) of MODPER and INCSTEP. As a result, the achieved modulation depth is quantized. The percentage quantized modulation depth is given by the following formula:

$$\text{md}_{\text{quantized}}\% = (\text{MODEPER} \times \text{INCSTEP} \times 100 \times 5) / ((2^{15} - 1) \times f_{\text{VCO\_OUT}})$$

As a result:

$$\text{md}_{\text{quantized}}\% = (25 \times 1258 \times 100 \times 5) / ((2^{15} - 1) \times 240) = 1.99954\%(\text{peak})$$

The error in modulation depth is consequently: 2.0 - 1.99954 = 0.00046%.

Figure 34 and Figure 35 show the main PLL output clock waveforms in center spread and down spread modes, where:

F0 is  $f_{PLL\_OUT}$  nominal.

$T_{mode}$  is the modulation period.

md is the modulation depth.

Figure 34. PLL output clock waveforms in center spread mode

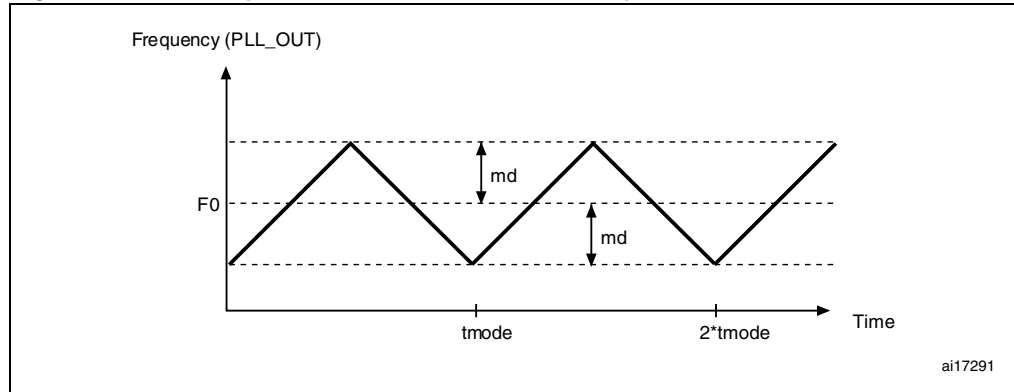
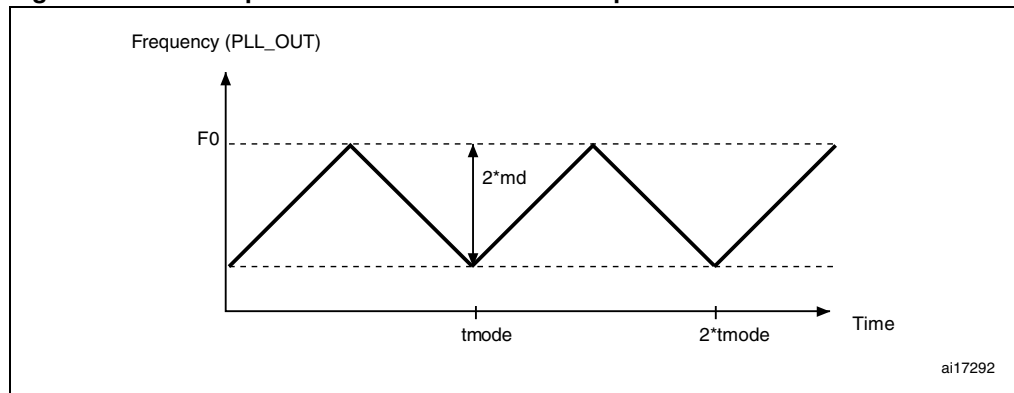


Figure 35. PLL output clock waveforms in down spread mode



### 5.3.12 Memory characteristics

#### Flash memory

The characteristics are given at  $T_A = -40$  to  $105$  °C unless otherwise specified.

Table 33. Flash memory characteristics<sup>(1)</sup>

Symbol	Parameter	Conditions	Min	Max	Unit
$I_{DD}$	Supply current	Read mode $f_{HCLK} = 120$ MHz with 3 wait states, $V_{DD} = 3.3$ V	-	100	mA
		Write / Erase modes $f_{HCLK} = 120$ MHz, $V_{DD} = 3.3$ V	-	TBD	mA

1. TBD stands for "to be defined".



Table 34. Flash memory programming<sup>(1)</sup>

Symbol	Parameter	Conditions	Min <sup>(2)</sup>	Typ	Max <sup>(2)</sup>	Unit
$t_{prog}$	Word programming time	Program/erase parallelism (PSIZE) = x 8/16/32	-	16	100 <sup>(3)</sup>	$\mu$ s
$t_{ERASE16KB}$	Sector (16 KB) erase time	Program/erase parallelism (PSIZE) = x 8	-	400	800	ms
		Program/erase parallelism (PSIZE) = x 16	-	300	600	
		Program/erase parallelism (PSIZE) = x 32	-	250	500	
$t_{ERASE64KB}$	Sector (64 KB) erase time	Program/erase parallelism (PSIZE) = x 8	-	1200	2400	ms
		Program/erase parallelism (PSIZE) = x 16	-	700	1400	
		Program/erase parallelism (PSIZE) = x 32	-	550	1100	
$t_{ERASE128KB}$	Sector (128 KB) erase time	Program/erase parallelism (PSIZE) = x 8	-	2	4	s
		Program/erase parallelism (PSIZE) = x 16	-	1.3	2.6	
		Program/erase parallelism (PSIZE) = x 32	-	1	2	
$t_{ME}$	Mass erase time	Program/erase parallelism (PSIZE) = x 8	-	16	TBD	s
		Program/erase parallelism (PSIZE) = x 16	-	11	TBD	
		Program/erase parallelism (PSIZE) = x 32	-	8	TBD	
$V_{prog}$	Programming voltage	32-bit program operation	2.7	-	3.6	V
		16-bit program operation	2.1	-	3.6	V
		8-bit program operation	1.8	-	3.6	V

1. TBD stands for "to be defined".

2. Based on characterization, not tested in production.

3. The maximum programming time is measured after 100K erase operations.

**Table 35. Flash memory programming with  $V_{PP}$ <sup>(1)</sup>**

Symbol	Parameter	Conditions	Min <sup>(2)</sup>	Typ	Max <sup>(2)</sup>	Unit
$t_{prog}$	Double word programming	$T_A = 0$ to $+40$ °C	-	16	100 <sup>(3)</sup>	$\mu$ s
$t_{ERASE16KB}$	Sector (16 KB) erase time		-	TBD	-	
$t_{ERASE64KB}$	Sector (64 KB) erase time		-	TBD	-	
$t_{ERASE128KB}$	Sector (128 KB) erase time		-	TBD	-	
$t_{ME}$	Mass erase time		-	6.8	-	
$V_{prog}$	Programming voltage		2.7	-	3.6	V
$V_{PP}$	$V_{PP}$ voltage range		7	-	9	V
$I_{PP}$	Minimum current sunk on the $V_{PP}$ pin		10	-	-	mA
$t_{VPP}$ <sup>(4)</sup>	Cumulative time during which $V_{PP}$ is applied		-	-	1	hour

1. TBD stands for "to be defined".
2. Guaranteed by design, not tested in production.
3. The maximum programming time is measured after 100K erase operations.
4.  $V_{PP}$  should only be connected during programming/erasing.

**Table 36. Flash memory endurance and data retention**

Symbol	Parameter	Conditions	Value	Unit
			Min <sup>(1)</sup>	
$N_{END}$	Endurance	$T_A = -40$ to $+85$ °C (6 suffix versions) $T_A = -40$ to $+105$ °C (7 suffix versions)	10	kcycles
$t_{RET}$	Data retention	1 kcycle <sup>(2)</sup> at $T_A = 85$ °C	30	Years
		1 kcycle <sup>(2)</sup> at $T_A = 105$ °C	10	
		10 kcycles <sup>(2)</sup> at $T_A = 55$ °C	20	

1. Based on characterization, not tested in production.
2. Cycling performed over the whole temperature range.

### 5.3.13 EMC characteristics

Susceptibility tests are performed on a sample basis during device characterization.

#### Functional EMS (electromagnetic susceptibility)

While a simple application is executed on the device (toggling 2 LEDs through I/O ports), the device is stressed by two electromagnetic events until a failure occurs. The failure is indicated by the LEDs:

- **Electrostatic discharge (ESD)** (positive and negative) is applied to all device pins until a functional disturbance occurs. This test is compliant with the IEC 61000-4-2 standard.
- **FTB**: A burst of fast transient voltage (positive and negative) is applied to  $V_{DD}$  and  $V_{SS}$  through a 100 pF capacitor, until a functional disturbance occurs. This test is compliant with the IEC 61000-4-4 standard.

A device reset allows normal operations to be resumed.

The test results are given in [Table 37](#). They are based on the EMS levels and classes defined in application note AN1709.

**Table 37. EMS characteristics**

Symbol	Parameter	Conditions	Level/Class
$V_{FESD}$	Voltage limits to be applied on any I/O pin to induce a functional disturbance	$V_{DD} = 3.3\text{ V}$ , LQFP100, $T_A = +25\text{ °C}$ , $f_{HCLK} = 75\text{ MHz}$ , conforms to IEC 61000-4-2	2B
$V_{EFTB}$	Fast transient voltage burst limits to be applied through 100 pF on $V_{DD}$ and $V_{SS}$ pins to induce a functional disturbance	$V_{DD} = 3.3\text{ V}$ , LQFP100, $T_A = +25\text{ °C}$ , $f_{HCLK} = 75\text{ MHz}$ , conforms to IEC 61000-4-2	4A

### Designing hardened software to avoid noise problems

EMC characterization and optimization are performed at component level with a typical application environment and simplified MCU software. It should be noted that good EMC performance is highly dependent on the user application and the software in particular.

Therefore it is recommended that the user applies EMC software optimization and prequalification tests in relation with the EMC level requested for his application.

#### Software recommendations

The software flowchart must include the management of runaway conditions such as:

- Corrupted program counter
- Unexpected reset
- Critical Data corruption (control registers...)

#### Prequalification trials

Most of the common failures (unexpected reset and program counter corruption) can be reproduced by manually forcing a low state on the NRST pin or the Oscillator pins for 1 second.

To complete these trials, ESD stress can be applied directly on the device, over the range of specification values. When unexpected behavior is detected, the software can be hardened to prevent unrecoverable errors occurring (see application note AN1015).

### Electromagnetic Interference (EMI)

The electromagnetic field emitted by the device are monitored while a simple application, executing EEMBC<sup>®</sup> code, is running. This emission test is compliant with SAE IEC61967-2 standard which specifies the test board and the pin loading.

Table 38. EMI characteristics

Symbol	Parameter	Conditions	Monitored frequency band	Max vs. [f <sub>HSE</sub> /f <sub>CPU</sub> ]	Unit
				8/120 MHz	
S <sub>EMI</sub>	Peak level	V <sub>DD</sub> = 3.3 V, T <sub>A</sub> = 25 °C, LQFP176 package, conforming to SAE J1752/3 EEMBC, code running with ART enabled	0.1 to 30 MHz	21	dBμV
			30 to 130 MHz	28	
			130 MHz to 1GHz	31	
			SAE EMI Level	4	
		V <sub>DD</sub> = 3.3 V, T <sub>A</sub> = 25 °C, LQFP176 package, conforming to SAE J1752/3 EEMBC, code running with ART enabled, PLL spread spectrum enabled	0.1 to 30 MHz	21	dBμV
			30 to 130 MHz	15	
			130 MHz to 1GHz	14	
			SAE EMI level	3.5	

### 5.3.14 Absolute maximum ratings (electrical sensitivity)

Based on three different tests (ESD, LU) using specific measurement methods, the device is stressed in order to determine its performance in terms of electrical sensitivity.

#### Electrostatic discharge (ESD)

Electrostatic discharges (a positive then a negative pulse separated by 1 second) are applied to the pins of each sample according to each pin combination. The sample size depends on the number of supply pins in the device (3 parts × (n+1) supply pins). This test conforms to the JESD22-A114/C101 standard.

Table 39. ESD absolute maximum ratings

Symbol	Ratings	Conditions	Class	Maximum value <sup>(1)</sup>	Unit
V <sub>ESD(HBM)</sub>	Electrostatic discharge voltage (human body model)	T <sub>A</sub> = +25 °C conforming to JESD22-A114	2	2000 <sup>(2)</sup>	V
V <sub>ESD(CDM)</sub>	Electrostatic discharge voltage (charge device model)	T <sub>A</sub> = +25 °C conforming to JESD22-C101	II	500	

1. Based on characterization results, not tested in production.

2. On V<sub>BAT</sub> pin, V<sub>ESD(HBM)</sub> is limited to 1000 V.

#### Static latch-up

Two complementary static tests are required on six parts to assess the latch-up performance:

- A supply overvoltage is applied to each power supply pin
- A current injection is applied to each input, output and configurable I/O pin

These tests are compliant with EIA/JESD 78A IC latch-up standard.

**Table 40. Electrical sensitivities**

Symbol	Parameter	Conditions	Class
LU	Static latch-up class	$T_A = +105\text{ }^\circ\text{C}$ conforming to JESD78A	II level A

### 5.3.15 I/O current injection characteristics

As a general rule, current injection to the I/O pins, due to external voltage below  $V_{SS}$  or above  $V_{DD}$  (for standard, 3 V-capable I/O pins) should be avoided during normal product operation. However, in order to give an indication of the robustness of the microcontroller in cases when abnormal injection accidentally happens, susceptibility tests are performed on a sample basis during device characterization.

#### Functional susceptibility to I/O current injection

While a simple application is executed on the device, the device is stressed by injecting current into the I/O pins programmed in floating input mode. While current is injected into the I/O pin, one at a time, the device is checked for functional failures.

The failure is indicated by an out of range parameter: ADC error above a certain limit (>5 LSB TUE), out of spec current injection on adjacent pins or other functional failure (for example reset, oscillator frequency deviation).

The test results are given in [Table 41](#).

**Table 41. I/O current injection susceptibility**

Symbol	Description	Functional susceptibility		Unit
		Negative injection	Positive injection	
$I_{INJ}$	Injected current on all FT pins	-5	+0	mA
	Injected current on any other pin	-5	+5	

### 5.3.16 I/O port characteristics

#### General input/output characteristics

Unless otherwise specified, the parameters given in [Table 42](#) are derived from tests performed under the conditions summarized in [Table 10](#). All I/Os are CMOS and TTL compliant.

**Table 42. I/O static characteristics**

Symbol	Parameter	Conditions	Min	Typ	Max	Unit	
$V_{IL}$	Input low level voltage	TTL ports $2.7\text{ V} \leq V_{DD} \leq 3.6\text{ V}$	$V_{SS}-0.3$	-	0.8	V	
$V_{IH}^{(1)}$	TT <sup>(2)</sup> I/O input high level voltage		2.0	-	$V_{DD}+0.3$		
	FT <sup>(3)</sup> I/O input high level voltage		2.0	-	5.5		
$V_{IL}$	Input low level voltage	CMOS ports $1.8\text{ V} \leq V_{DD} \leq 3.6\text{ V}$	$V_{SS}-0.3$	-	$0.3V_{DD}$	V	
$V_{IH}^{(1)}$	TT I/O input high level voltage		$0.7V_{DD}$	-	-		$3.6^{(4)}$
	FT I/O input high level voltage			-	-		$5.2^{(4)}$
$V_{hys}$	I/O Schmitt trigger voltage hysteresis <sup>(5)</sup>		-	200	-	mV	
	IO FT Schmitt trigger voltage hysteresis <sup>(5)</sup>		$5\% V_{DD}^{(4)}$	-	-		
$I_{lkg}$	I/O input leakage current <sup>(6)</sup>	$V_{SS} \leq V_{IN} \leq V_{DD}$	-	-	$\pm 1$	$\mu\text{A}$	
	I/O FT input leakage current <sup>(6)</sup>	$V_{IN} = 5\text{ V}$	-	-	3		
$R_{PU}$	Weak pull-up equivalent resistor <sup>(7)</sup>	All pins except for PA10 and PB12	$V_{IN} = V_{SS}$	30	40	50	k $\Omega$
		PA10 and PB12		8	11	15	
$R_{PD}$	Weak pull-down equivalent resistor	All pins except for PA10 and PB12	$V_{IN} = V_{DD}$	30	40	50	k $\Omega$
		PA10 and PB12		8	11	15	
$C_{IO}^{(8)}$	I/O pin capacitance			5		pF	

1. If  $V_{IH}$  maximum value cannot be respected, the injection current must be limited externally to  $I_{INJ(PIN)}$  maximum value.
2. TT = 3.6 V tolerant.
3. FT = 5 V tolerant.
4. With a minimum of 100 mV.
5. Hysteresis voltage between Schmitt trigger switching levels. Based on characterization, not tested in production.
6. Leakage could be higher than the maximum value, if negative current is injected on adjacent pins.
7. Pull-up and pull-down resistors are designed with a true resistance in series with a switchable PMOS/NMOS. This MOS/NMOS contribution to the series resistance is minimum (~10% order).
8. Guaranteed by design, not tested in production.

All I/Os are CMOS and TTL compliant (no software configuration required). Their characteristics cover more than the strict CMOS-technology or TTL parameters.

### Output driving current

The GPIOs (general purpose input/outputs) can sink or source up to  $\pm 8$  mA, and sink or source  $\pm 20$  mA (with a relaxed  $V_{OL}/V_{OH}$ ).

In the user application, the number of I/O pins which can drive current must be limited to respect the absolute maximum rating specified in [Section 5.2](#):

- The sum of the currents sourced by all the I/Os on  $V_{DD}$ , plus the maximum Run consumption of the MCU sourced on  $V_{DD}$ , cannot exceed the absolute maximum rating  $I_{VDD}$  (see [Table 8](#)).
- The sum of the currents sunk by all the I/Os on  $V_{SS}$  plus the maximum Run consumption of the MCU sunk on  $V_{SS}$  cannot exceed the absolute maximum rating  $I_{VSS}$  (see [Table 8](#)).

### Output voltage levels

Unless otherwise specified, the parameters given in [Table 43](#) are derived from tests performed under ambient temperature and  $V_{DD}$  supply voltage conditions summarized in [Table 10](#). All I/Os are CMOS and TTL compliant.

**Table 43. Output voltage characteristics<sup>(1)</sup>**

Symbol	Parameter	Conditions	Min	Max	Unit
$V_{OL}^{(2)}$	Output low level voltage for an I/O pin when 8 pins are sunk at same time	TTL port $I_{IO} = +8$ mA $2.7$ V < $V_{DD}$ < $3.6$ V	-	0.4	V
$V_{OH}^{(3)}$	Output high level voltage for an I/O pin when 8 pins are sourced at same time		$V_{DD}-0.4$	-	
$V_{OL}^{(2)}$	Output low level voltage for an I/O pin when 8 pins are sunk at same time	CMOS port $I_{IO} = +8$ mA $2.7$ V < $V_{DD}$ < $3.6$ V	-	0.4	V
$V_{OH}^{(3)}$	Output high level voltage for an I/O pin when 8 pins are sourced at same time		2.4	-	
$V_{OL}^{(2)(4)}$	Output low level voltage for an I/O pin when 8 pins are sunk at same time	$I_{IO} = +20$ mA $2.7$ V < $V_{DD}$ < $3.6$ V	-	1.3	V
$V_{OH}^{(3)(4)}$	Output high level voltage for an I/O pin when 8 pins are sourced at same time		$V_{DD}-1.3$	-	
$V_{OL}^{(2)(4)}$	Output low level voltage for an I/O pin when 8 pins are sunk at same time	$I_{IO} = +6$ mA $2$ V < $V_{DD}$ < $2.7$ V	-	0.4	V
$V_{OH}^{(3)(4)}$	Output high level voltage for an I/O pin when 8 pins are sourced at same time		$V_{DD}-0.4$	-	

1. PC13, PC14, PC15 and PI8 are supplied through the power switch. Since the switch only sinks a limited amount of current (3 mA), the use of GPIOs PC13 to PC15 and PI8 in output mode is limited: the speed should not exceed 2 MHz with a maximum load of 30 pF and these I/Os must not be used as a current source (e.g. to drive an LED).
2. The  $I_{IO}$  current sunk by the device must always respect the absolute maximum rating specified in [Table 8](#) and the sum of  $I_{IO}$  (I/O ports and control pins) must not exceed  $I_{VSS}$ .
3. The  $I_{IO}$  current sourced by the device must always respect the absolute maximum rating specified in [Table 8](#) and the sum of  $I_{IO}$  (I/O ports and control pins) must not exceed  $I_{VDD}$ .
4. Based on characterization data, not tested in production.

### Input/output AC characteristics

The definition and values of input/output AC characteristics are given in [Figure 36](#) and [Table 44](#), respectively.

Unless otherwise specified, the parameters given in [Table 44](#) are derived from tests performed under the ambient temperature and  $V_{DD}$  supply voltage conditions summarized in [Table 10](#).

**Table 44.** I/O AC characteristics<sup>(1)(2)</sup>

OSPEEDRy [1:0] bit value <sup>(1)</sup>	Symbol	Parameter	Conditions	Min	Typ	Max	Unit
00	$f_{\max(\text{IO})\text{out}}$	Maximum frequency <sup>(3)</sup>	$C_L = 50 \text{ pF}, V_{DD} > 2.70 \text{ V}$	-	-	2	MHz
			$C_L = 50 \text{ pF}, V_{DD} > 1.8 \text{ V}$	-	-	2	
			$C_L = 10 \text{ pF}, V_{DD} > 2.70 \text{ V}$	-	-	TBD	
			$C_L = 10 \text{ pF}, V_{DD} > 1.8 \text{ V}$	-	-	TBD	
	$t_{f(\text{IO})\text{out}}$	Output high to low level fall time	$C_L = 50 \text{ pF}, V_{DD} = 1.8 \text{ V to } 3.6 \text{ V}$	-	-	TBD	ns
				$t_{r(\text{IO})\text{out}}$	Output low to high level rise time	-	
01	$f_{\max(\text{IO})\text{out}}$	Maximum frequency <sup>(3)</sup>	$C_L = 50 \text{ pF}, V_{DD} > 2.70 \text{ V}$	-	-	25	MHz
			$C_L = 50 \text{ pF}, V_{DD} > 1.8 \text{ V}$	-	-	12.5 <sup>(4)</sup>	
			$C_L = 10 \text{ pF}, V_{DD} > 2.70 \text{ V}$	-	-	50 <sup>(4)</sup>	
			$C_L = 10 \text{ pF}, V_{DD} > 1.8 \text{ V}$	-	-	TBD	
	$t_{f(\text{IO})\text{out}}$	Output high to low level fall time	$C_L = 50 \text{ pF}, V_{DD} < 2.7 \text{ V}$	-	-	TBD	ns
				$C_L = 10 \text{ pF}, V_{DD} > 2.7 \text{ V}$	-	-	
	$t_{r(\text{IO})\text{out}}$	Output low to high level rise time	$C_L = 50 \text{ pF}, V_{DD} < 2.7 \text{ V}$	-	-	TBD	ns
				$C_L = 10 \text{ pF}, V_{DD} > 2.7 \text{ V}$	-	-	
10	$f_{\max(\text{IO})\text{out}}$	Maximum frequency <sup>(3)</sup>	$C_L = 40 \text{ pF}, V_{DD} > 2.70 \text{ V}$	-	-	50 <sup>(4)</sup>	MHz
			$C_L = 40 \text{ pF}, V_{DD} > 1.8 \text{ V}$	-	-	25	
			$C_L = 10 \text{ pF}, V_{DD} > 2.70 \text{ V}$	-	-	100 <sup>(4)</sup>	
			$C_L = 10 \text{ pF}, V_{DD} > 1.8 \text{ V}$	-	-	TBD	
	$t_{f(\text{IO})\text{out}}$	Output high to low level fall time	$C_L = 50 \text{ pF}, 2.4 < V_{DD} < 2.7 \text{ V}$	-	-	TBD	ns
				$C_L = 10 \text{ pF}, V_{DD} > 2.7 \text{ V}$	-	-	
	$t_{r(\text{IO})\text{out}}$	Output low to high level rise time	$C_L = 50 \text{ pF}, 2.4 < V_{DD} < 2.7 \text{ V}$	-	-	TBD	ns
				$C_L = 10 \text{ pF}, V_{DD} > 2.7 \text{ V}$	-	-	

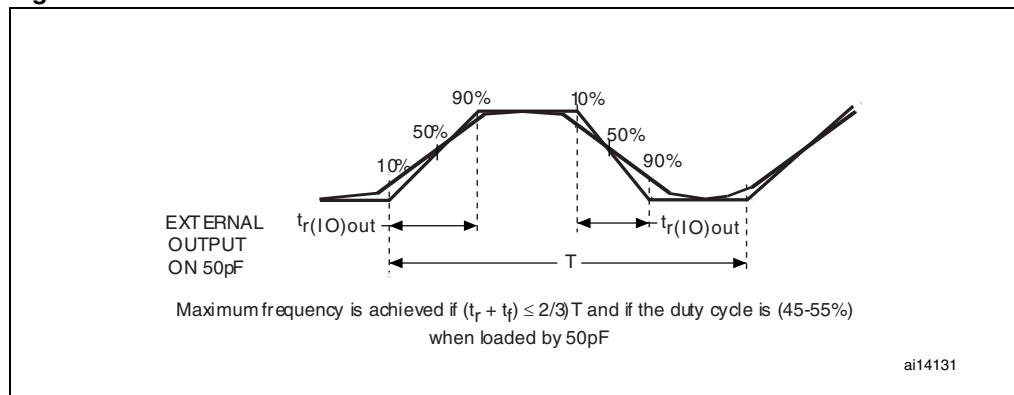


Table 44. I/O AC characteristics<sup>(1)(2)</sup> (continued)

OSPEEDRy [1:0] bit value <sup>(1)</sup>	Symbol	Parameter	Conditions	Min	Typ	Max	Unit
11	F <sub>max(IO)out</sub>	Maximum frequency <sup>(3)</sup>	C <sub>L</sub> = 30 pF, V <sub>DD</sub> > 2.70 V	-	-	100 <sup>(4)</sup>	MHz
			C <sub>L</sub> = 30 pF, V <sub>DD</sub> > 1.8 V	-	-	50 <sup>(4)</sup>	
			C <sub>L</sub> = 10 pF, V <sub>DD</sub> > 2.70 V	-	-	200 <sup>(4)</sup>	
			C <sub>L</sub> = 10 pF, V <sub>DD</sub> > 1.8 V	-	-	TBD	
	t <sub>r(IO)out</sub>	Output high to low level fall time	C <sub>L</sub> = 20 pF, 2.4 < V <sub>DD</sub> < 2.7 V	-	-	TBD	ns
			C <sub>L</sub> = 10 pF, V <sub>DD</sub> > 2.7 V	-	-	TBD	
t <sub>r(IO)out</sub>	Output low to high level rise time	C <sub>L</sub> = 20 pF, 2.4 < V <sub>DD</sub> < 2.7 V	-	-	TBD	ns	
		C <sub>L</sub> = 10 pF, V <sub>DD</sub> > 2.7 V	-	-	TBD		
-	t <sub>EXTIpw</sub>	Pulse width of external signals detected by the EXTI controller		10	-	-	ns

- The I/O speed is configured using the OSPEEDRy[1:0] bits. Refer to the STM32F20/21xxx reference manual for a description of the GPIOx\_SPEEDR GPIO port output speed register.
- TBD stands for "to be defined".
- The maximum frequency is defined in [Figure 36](#).
- For maximum frequencies above 50 MHz, the compensation cell should be used.

Figure 36. I/O AC characteristics definition



### 5.3.17 NRST pin characteristics

The NRST pin input driver uses CMOS technology. It is connected to a permanent pull-up resistor,  $R_{PU}$  (see [Table 42](#)).

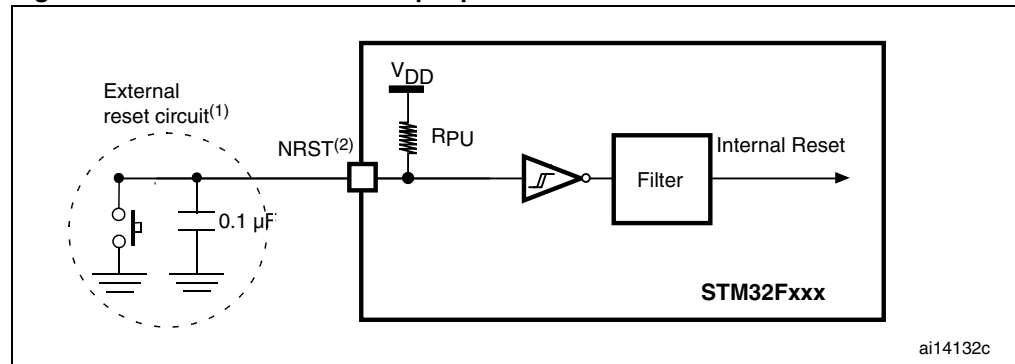
Unless otherwise specified, the parameters given in [Table 45](#) are derived from tests performed under the ambient temperature and  $V_{DD}$  supply voltage conditions summarized in [Table 10](#).

**Table 45. NRST pin characteristics**

Symbol	Parameter	Conditions	Min	Typ	Max	Unit
$V_{IL(NRST)}^{(1)}$	NRST Input low level voltage		-0.5	-	0.8	V
$V_{IH(NRST)}^{(1)}$	NRST Input high level voltage		2	-	$V_{DD}+0.5$	
$V_{hys(NRST)}$	NRST Schmitt trigger voltage hysteresis		-	200	-	mV
$R_{PU}$	Weak pull-up equivalent resistor <sup>(2)</sup>	$V_{IN} = V_{SS}$	30	40	50	k $\Omega$
$V_{F(NRST)}^{(1)}$	NRST Input filtered pulse		-	-	100	ns
$V_{NF(NRST)}^{(1)}$	NRST Input not filtered pulse	$V_{DD} > 2.7$ V	300	-	-	ns
$T_{NRST\_OUT}$	Generated reset pulse duration	Internal Reset source	20	-	-	$\mu$ s

1. Guaranteed by design, not tested in production.
2. The pull-up is designed with a true resistance in series with a switchable PMOS. This PMOS contribution to the series resistance must be minimum (~10% order).

**Figure 37. Recommended NRST pin protection**



2. The reset network protects the device against parasitic resets.
3. The user must ensure that the level on the NRST pin can go below the  $V_{IL(NRST)}$  max level specified in [Table 45](#). Otherwise the reset is not taken into account by the device.

### 5.3.18 TIM timer characteristics

The parameters given in [Table 46](#) and [Table 47](#) are guaranteed by design.

Refer to [Section 5.3.16: I/O port characteristics](#) for details on the input/output alternate function characteristics (output compare, input capture, external clock, PWM output).

**Table 46. Characteristics of TIMx connected to the APB1 domain<sup>(1)</sup>**

Symbol	Parameter	Conditions	Min	Max	Unit
$t_{res(TIM)}$	Timer resolution time	AHB/APB1 prescaler distinct from 1, $f_{TIMxCLK} = 60$ MHz	1	-	$t_{TIMxCLK}$
			16.7	-	ns
		AHB/APB1 prescaler = 1, $f_{TIMxCLK} = 30$ MHz	1	-	$t_{TIMxCLK}$
			33.3	-	ns
$f_{EXT}$	Timer external clock frequency on CH1 to CH4	$f_{TIMxCLK} = 60$ MHz APB1 = 30 MHz	0	$f_{TIMxCLK}/2$	MHz
			0	30	MHz
Res <sub>TIM</sub>	Timer resolution		-	16/32	bit
$t_{COUNTER}$	16-bit counter clock period when internal clock is selected		1	65536	$t_{TIMxCLK}$
	32-bit counter clock period when internal clock is selected		0.0167	1092	$\mu$ s
$t_{MAX\_COUNT}$	Maximum possible count		1	-	$t_{TIMxCLK}$
		0.0167	71582788	$\mu$ s	
$t_{MAX\_COUNT}$	Maximum possible count	-	$65536 \times 65536$	$t_{TIMxCLK}$	
		-	71.6	s	

1. TIMx is used as a general term to refer to the TIM2, TIM3, TIM4, TIM5, TIM6, TIM7, and TIM12 timers.

**Table 47. Characteristics of TIMx connected to the APB2 domain<sup>(1)</sup>**

Symbol	Parameter	Conditions	Min	Max	Unit
$t_{res(TIM)}$	Timer resolution time	AHB/APB2 prescaler distinct from 1, $f_{TIMxCLK} = 120$ MHz	1	-	$t_{TIMxCLK}$
			8.3	-	ns
		AHB/APB2 prescaler = 1, $f_{TIMxCLK} = 60$ MHz	1	-	$t_{TIMxCLK}$
			16.7	-	ns
$f_{EXT}$	Timer external clock frequency on CH1 to CH4	$f_{TIMxCLK} = 120$ MHz APB2 = 60 MHz	0	$f_{TIMxCLK}/2$	MHz
			0	60	MHz
$Res_{TIM}$	Timer resolution		-	16	bit
$t_{COUNTER}$	16-bit counter clock period when internal clock is selected		1	65536	$t_{TIMxCLK}$
			0.0083	546	$\mu$ s
$t_{MAX\_COUNT}$	Maximum possible count		-	$65536 \times 65536$	$t_{TIMxCLK}$
		-	35.79	s	

1. TIMx is used as a general term to refer to the TIM1, TIM8, TIM9, TIM10, and TIM11 timers.

### 5.3.19 Communications interfaces

#### I<sup>2</sup>C interface characteristics

Unless otherwise specified, the parameters given in [Table 48](#) are derived from tests performed under the ambient temperature,  $f_{PCLK1}$  frequency and  $V_{DD}$  supply voltage conditions summarized in [Table 10](#).

STM32F215xx and STM32F217xx I<sup>2</sup>C interface meets the requirements of the standard I<sup>2</sup>C communication protocol with the following restrictions: the I/O pins SDA and SCL are mapped to are not “true” open-drain. When configured as open-drain, the PMOS connected between the I/O pin and  $V_{DD}$  is disabled, but is still present.

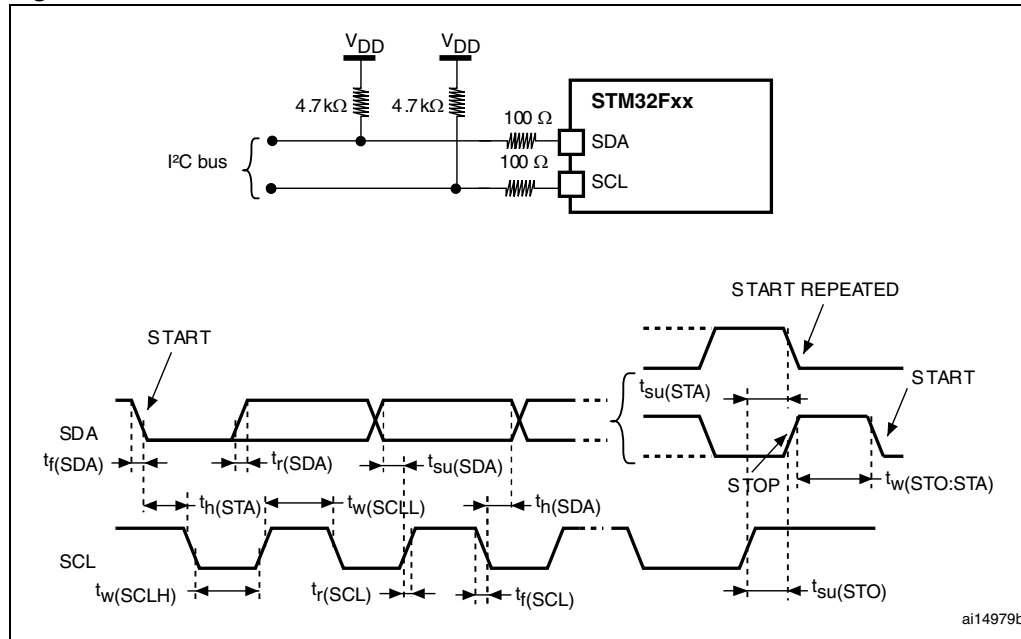
The I<sup>2</sup>C characteristics are described in [Table 48](#). Refer also to [Section 5.3.16: I/O port characteristics](#) for more details on the input/output alternate function characteristics (SDA and SCL).

Table 48. I<sup>2</sup>C characteristics

Symbol	Parameter	Standard mode I <sup>2</sup> C <sup>(1)</sup>		Fast mode I <sup>2</sup> C <sup>(1)(2)</sup>		Unit
		Min	Max	Min	Max	
t <sub>w</sub> (SCLL)	SCL clock low time	4.7	-	1.3	-	μs
t <sub>w</sub> (SCLH)	SCL clock high time	4.0	-	0.6	-	
t <sub>su</sub> (SDA)	SDA setup time	250	-	100	-	ns
t <sub>h</sub> (SDA)	SDA data hold time	0 <sup>(3)</sup>	-	0 <sup>(4)</sup>	900 <sup>(3)</sup>	
t <sub>r</sub> (SDA) t <sub>r</sub> (SCL)	SDA and SCL rise time	-	1000	20 + 0.1C <sub>b</sub>	300	
t <sub>f</sub> (SDA) t <sub>f</sub> (SCL)	SDA and SCL fall time	-	300	-	300	
t <sub>h</sub> (STA)	Start condition hold time	4.0	-	0.6	-	μs
t <sub>su</sub> (STA)	Repeated Start condition setup time	4.7	-	0.6	-	
t <sub>su</sub> (STO)	Stop condition setup time	4.0	-	0.6	-	μs
t <sub>w</sub> (STO:STA)	Stop to Start condition time (bus free)	4.7	-	1.3	-	μs
C <sub>b</sub>	Capacitive load for each bus line	-	400	-	400	pF

1. Guaranteed by design, not tested in production.
2. f<sub>PCLK1</sub> must be at least 2 MHz to achieve standard mode I<sup>2</sup>C frequencies. It must be at least 4 MHz to achieve fast mode I<sup>2</sup>C frequencies, and a multiple of 10 MHz to reach the 400 kHz maximum I<sup>2</sup>C fast mode clock.
3. The maximum hold time of the Start condition has only to be met if the interface does not stretch the low period of SCL signal.
4. The device must internally provide a hold time of at least 300ns for the SDA signal in order to bridge the undefined region of the falling edge of SCL.

Figure 38. I<sup>2</sup>C bus AC waveforms and measurement circuit



1. Measurement points are done at CMOS levels: 0.3V<sub>DD</sub> and 0.7V<sub>DD</sub>.

Table 49. SCL frequency (f<sub>PCLK1</sub> = 30 MHz, V<sub>DD</sub> = 3.3 V)<sup>(1)(2)</sup>

f <sub>SCL</sub> (kHz)	I2C_CCR value
	R <sub>p</sub> = 4.7 kΩ
400	0x8019
300	0x8021
200	0x8032
100	0x0096
50	0x012C
20	0x02EE

- R<sub>p</sub> = External pull-up resistance, f<sub>SCL</sub> = I<sup>2</sup>C speed,
- For speeds around 200 kHz, the tolerance on the achieved speed is of ±5%. For other speed ranges, the tolerance on the achieved speed is ±2%. These variations depend on the accuracy of the external components used to design the application.

## I<sup>2</sup>S - SPI interface characteristics

Unless otherwise specified, the parameters given in [Table 50](#) for SPI or in [Table 51](#) for I<sup>2</sup>S are derived from tests performed under the ambient temperature,  $f_{PCLKx}$  frequency and  $V_{DD}$  supply voltage conditions summarized in [Table 10](#).

Refer to [Section 5.3.16: I/O port characteristics](#) for more details on the input/output alternate function characteristics (NSS, SCK, MOSI, MISO for SPI and WS, CK, SD for I<sup>2</sup>S).

**Table 50. SPI characteristics<sup>(1)</sup>**

Symbol	Parameter	Conditions	Min	Max	Unit
$f_{SCK}$ $1/t_c(SCK)$	SPI clock frequency	Master mode	-	30	MHz
		Slave mode	-	30	
$t_r(SCL)$ $t_f(SCL)$	SPI clock rise and fall time	Capacitive load: C = 30 pF	-	8	ns
DuCy(SCK)	SPI slave input clock duty cycle	Slave mode	30	70	%
$t_{su(NSS)}^{(2)}$	NSS setup time	Slave mode	$4t_{PCLK}$	-	ns
$t_h(NSS)^{(2)}$	NSS hold time	Slave mode	$2t_{PCLK}$	-	
$t_w(SCLH)^{(2)}$ $t_w(SCLL)^{(2)}$	SCK high and low time	Master mode, $f_{PCLK} = 30$ MHz, presc = 2	$t_{PCLK}-3$	$t_{PCLK}+3$	
$t_{su(MI)}^{(2)}$ $t_{su(SI)}^{(2)}$	Data input setup time	Master mode	5	-	
		Slave mode	5	-	
$t_h(MI)^{(2)}$ $t_h(SI)^{(2)}$	Data input hold time	Master mode	5	-	
		Slave mode	4	-	
$t_a(SO)^{(2)(3)}$	Data output access time	Slave mode, $f_{PCLK} = 20$ MHz	0	$3t_{PCLK}$	
$t_{dis(SO)}^{(2)(4)}$	Data output disable time	Slave mode	2	10	
$t_v(SO)^{(2)(1)}$	Data output valid time	Slave mode (after enable edge)	-	25	
$t_v(MO)^{(2)(1)}$	Data output valid time	Master mode (after enable edge)	-	5	
$t_h(SO)^{(2)}$ $t_h(MO)^{(2)}$	Data output hold time	Slave mode (after enable edge)	15	-	
		Master mode (after enable edge)	2	-	

1. Remapped SPI1 characteristics to be determined.
2. Based on characterization, not tested in production.
3. Min time is for the minimum time to drive the output and the max time is for the maximum time to validate the data.
4. Min time is for the minimum time to invalidate the output and the max time is for the maximum time to put the data in Hi-Z

Figure 39. SPI timing diagram - slave mode and CPHA = 0

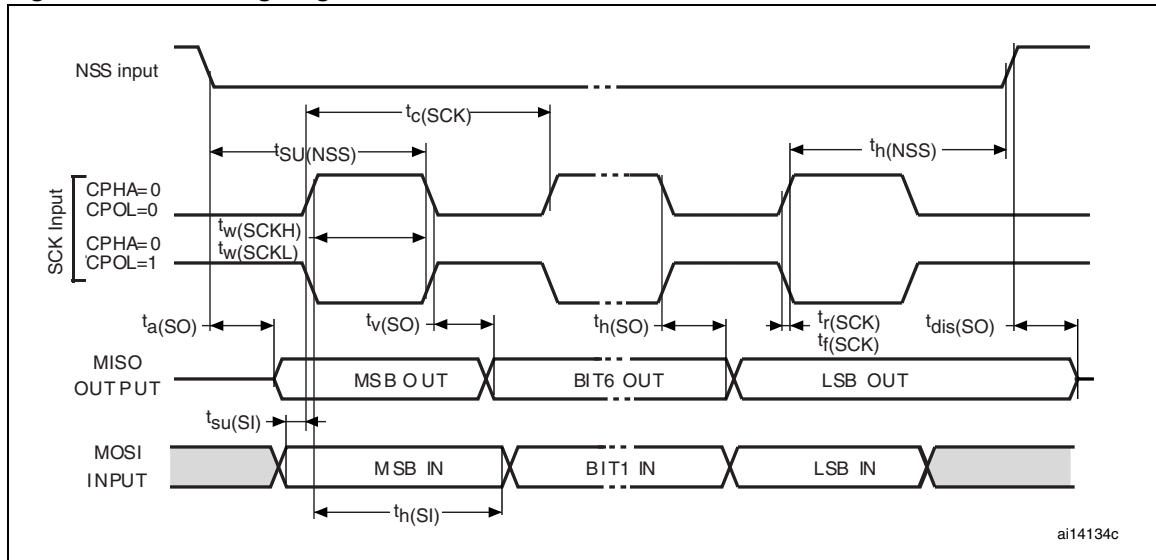
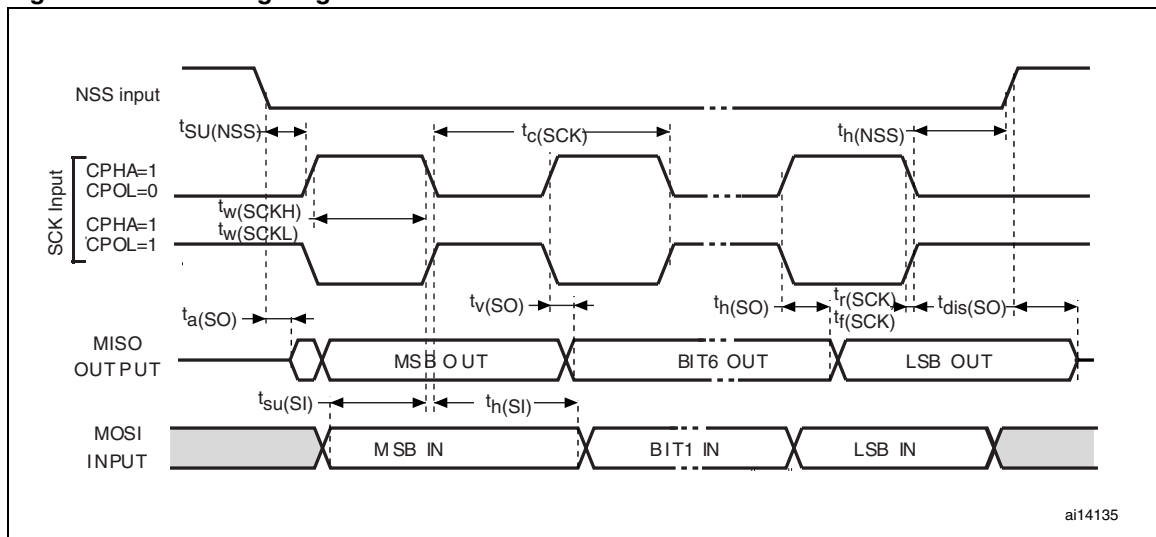


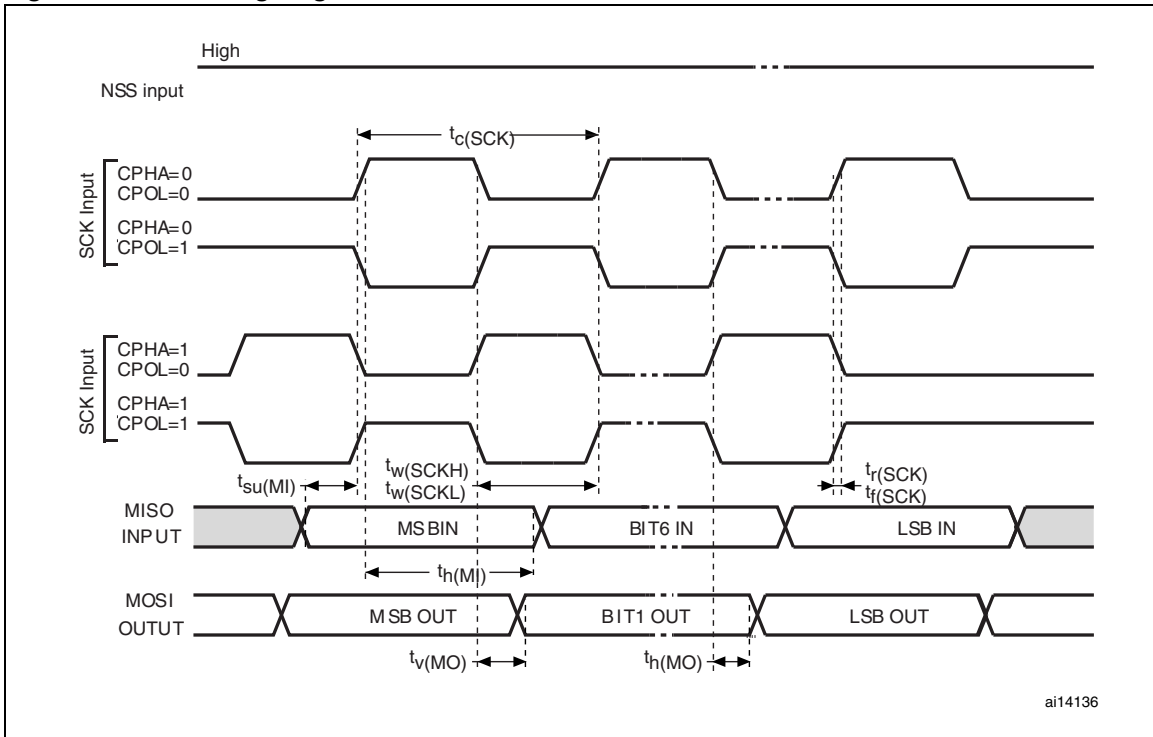
Figure 40. SPI timing diagram - slave mode and CPHA = 1<sup>(1)</sup>



1. Measurement points are done at CMOS levels:  $0.3V_{DD}$  and  $0.7V_{DD}$ .



Figure 41. SPI timing diagram - master mode<sup>(1)</sup>



1. Measurement points are done at CMOS levels:  $0.3V_{DD}$  and  $0.7V_{DD}$ .

Table 51. I<sup>2</sup>S characteristics<sup>(1)</sup>

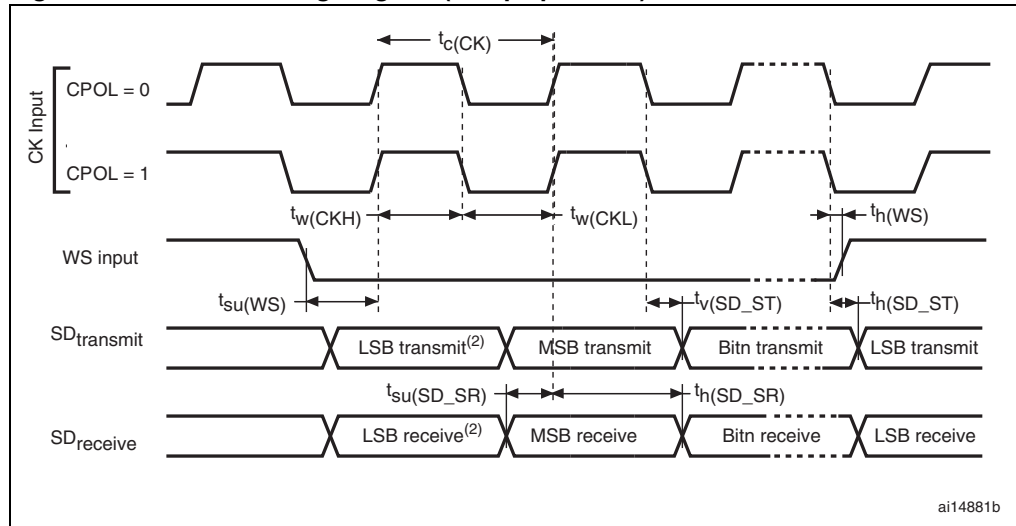
Symbol	Parameter	Conditions	Min	Max	Unit
$f_{CK}$ $1/t_{c(CK)}$	I <sup>2</sup> S clock frequency	Master	1.23	1.24	MHz
		Slave	0	TBD	
$t_{r(CK)}$ $t_{f(CK)}$	I <sup>2</sup> S clock rise and fall time	capacitive load $C_L = 50$ pF	-	TBD	ns
$t_{v(WS)}^{(2)}$	WS valid time	Master	0.3	-	
$t_{h(WS)}^{(2)}$	WS hold time	Master	0	-	
$t_{su(WS)}^{(2)}$	WS setup time	Slave	3	-	
$t_{h(WS)}^{(2)}$	WS hold time	Slave	0	-	
$t_{w(CKH)}^{(2)}$ $t_{w(CKL)}^{(2)}$	CK high and low time	Master $f_{PCLK} = 120$ MHz, presc = 7	396	-	
$t_{su(SD\_MR)}^{(2)}$ $t_{su(SD\_SR)}^{(2)}$	Data input setup time	Master receiver Slave receiver	45 0	-	
$t_{h(SD\_MR)}^{(2)(3)}$ $t_{h(SD\_SR)}^{(2)(3)}$	Data input hold time	Master receiver Slave receiver	13 0	-	
$t_{h(SD\_MR)}^{(2)}$ $t_{h(SD\_SR)}^{(2)}$	Data input hold time	Master $f_{PCLK} = 120$ MHz, Slave $f_{PCLK} = 120$ MHz	13 0	-	
$t_{v(SD\_ST)}^{(2)(3)}$	Data output valid time	Slave transmitter (after enable edge)	-	12	
		$f_{PCLK} = 120$ MHz	-	12	
$t_{h(SD\_ST)}^{(2)}$	Data output hold time	Slave transmitter (after enable edge)	10	-	
$t_{v(SD\_MT)}^{(2)(3)}$	Data output valid time	Master transmitter (after enable edge)	-	4	
		$f_{PCLK} = 120$ MHz	4	6	
$t_{h(SD\_MT)}^{(2)}$	Data output hold time	Master transmitter (after enable edge)	0	-	

1. TBD stands for "to be defined".

2. Based on design simulation and/or characterization results, not tested in production.

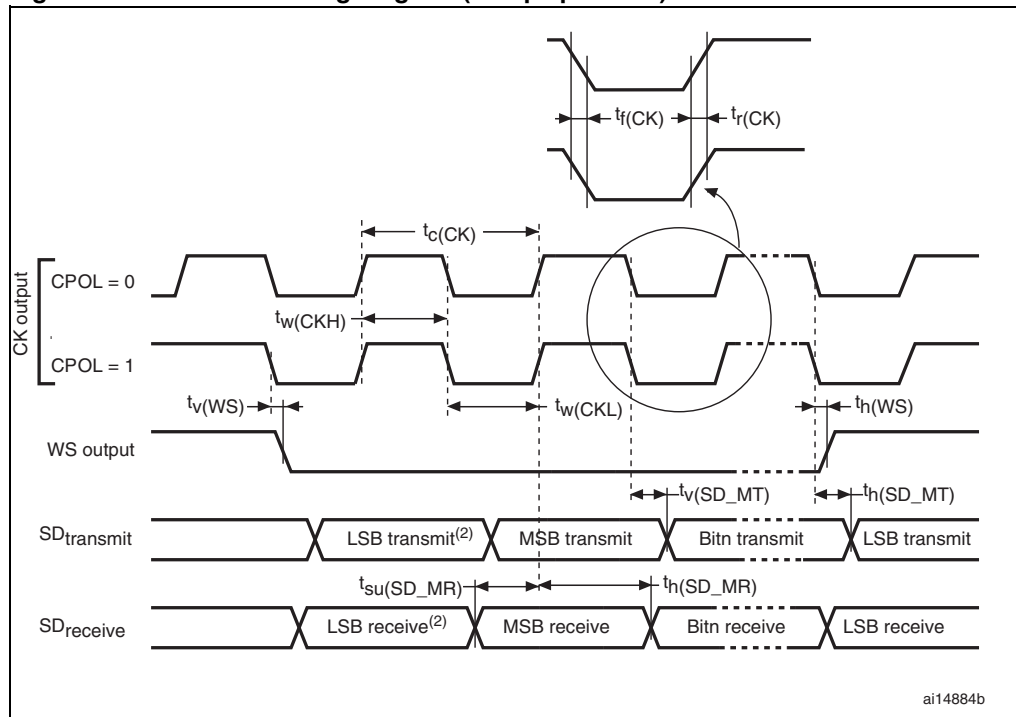
3. Depends on  $f_{PCLK}$ . For example, if  $f_{PCLK} = 8$  MHz, then  $T_{PCLK} = 1/f_{PCLK} = 125$  ns.

Figure 42. I<sup>2</sup>S slave timing diagram (Philips protocol)<sup>(1)</sup>



1. Measurement points are done at CMOS levels:  $0.3 \times V_{DD}$  and  $0.7 \times V_{DD}$ .
2. LSB transmit/receive of the previously transmitted byte. No LSB transmit/receive is sent before the first byte.

Figure 43. I<sup>2</sup>S master timing diagram (Philips protocol)<sup>(1)</sup>



1. Based on characterization, not tested in production.
2. LSB transmit/receive of the previously transmitted byte. No LSB transmit/receive is sent before the first byte.

**USB OTG FS characteristics**

The USB OTG interface is USB-IF certified (Full-Speed). This interface is present in both the USB OTG HS and USB OTG FS controllers.

**Table 52. USB OTG FS startup time**

Symbol	Parameter	Max	Unit
$t_{\text{STARTUP}}^{(1)}$	USB OTG FS transceiver startup time	1	$\mu\text{s}$

1. Guaranteed by design, not tested in production.

**Table 53. USB OTG FS DC electrical characteristics**

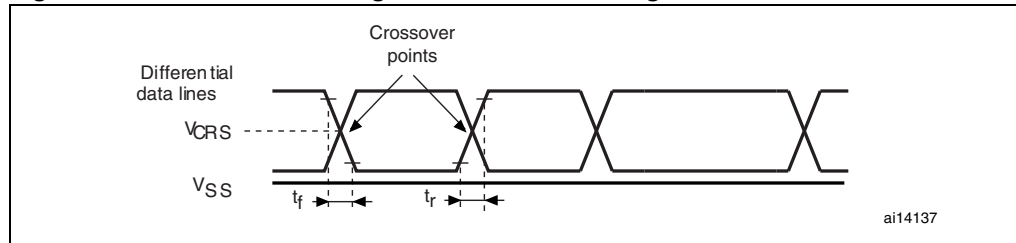
Symbol	Parameter	Conditions	Min. <sup>(1)</sup>	Typ.	Max. <sup>(1)</sup>	Unit	
Input levels	$V_{\text{DD}}$	USB OTG FS operating voltage	3.0 <sup>(2)</sup>	-	3.6	V	
	$V_{\text{DI}}^{(3)}$	Differential input sensitivity	I(USB_FS_DP/DM, USB_HS_DP/DM)	0.2	-	-	V
	$V_{\text{CM}}^{(3)}$	Differential common mode range	Includes $V_{\text{DI}}$ range	0.8	-	2.5	
	$V_{\text{SE}}^{(3)}$	Single ended receiver threshold		1.3	-	2.0	
Output levels	$V_{\text{OL}}$	Static output level low	$R_{\text{L}}$ of 1.5 k $\Omega$ to 3.6 V <sup>(4)</sup>	-	-	0.3	V
	$V_{\text{OH}}$	Static output level high	$R_{\text{L}}$ of 15 k $\Omega$ to $V_{\text{SS}}^{(4)}$	2.8	-	3.6	
$R_{\text{PD}}$	PA11, PA12, PB14, PB15 (USB_FS_DP/DM, USB_HS_DP/DM)	$V_{\text{IN}} = V_{\text{DD}}$	17	21	24	k $\Omega$	
	PA9, PB13 (OTG_FS_VBUS, OTG_HS_VBUS)		0.65	1.1	2.0		
$R_{\text{PU}}$	PA12, PB15 (USB_FS_DP, USB_HS_DP)	$V_{\text{IN}} = V_{\text{SS}}$	1.5	1.8	2.1		
	PA9, PB13 (OTG_FS_VBUS, OTG_HS_VBUS)	$V_{\text{IN}} = V_{\text{SS}}$	0.25	0.37	0.55		

1. All the voltages are measured from the local ground potential.

2. The STM32F215xx and STM32F217xx USB OTG FS functionality is ensured down to 2.7 V but not the full USB OTG FS electrical characteristics which are degraded in the 2.7-to-3.0 V  $V_{\text{DD}}$  voltage range.

3. Guaranteed by design, not tested in production.

4.  $R_{\text{L}}$  is the load connected on the USB OTG FS drivers

**Figure 44. USB OTG FS timings: definition of data signal rise and fall time****Table 54. USB OTG FS electrical characteristics<sup>(1)</sup>**

Driver characteristics					
Symbol	Parameter	Conditions	Min	Max	Unit
$t_r$	Rise time <sup>(2)</sup>	$C_L = 50 \text{ pF}$	4	20	ns
$t_f$	Fall time <sup>(2)</sup>	$C_L = 50 \text{ pF}$	4	20	ns
$t_{rfm}$	Rise/ fall time matching	$t_r/t_f$	90	110	%
$V_{CRS}$	Output signal crossover voltage		1.3	2.0	V

1. Guaranteed by design, not tested in production.
2. Measured from 10% to 90% of the data signal. For more detailed informations, please refer to USB Specification - Chapter 7 (version 2.0).

## USB HS characteristics

[Table 55](#) shows the USB HS operating voltage.

**Table 55. USB HS DC electrical characteristics**

Symbol	Parameter	Min. <sup>(1)</sup>	Max. <sup>(1)</sup>	Unit	
Input level	$V_{DD}$	Ethernet operating voltage	2.7	3.6	V

1. All the voltages are measured from the local ground potential.

**Table 56. Clock timing parameters**

Parameter <sup>(1)</sup>		Symbol	Min	Nominal	Max	Unit
Frequency (first transition)	8-bit $\pm 10\%$	$F_{START\_8BIT}$	54	60	66	MHz
Frequency (steady state) $\pm 500$ ppm		$F_{STEADY}$	59.97	60	60.03	MHz
Duty cycle (first transition)	8-bit $\pm 10\%$	$D_{START\_8BIT}$	40	50	60	%
Duty cycle (steady state) $\pm 500$ ppm		$D_{STEADY}$	49.975	50	50.025	%
Time to reach the steady state frequency and duty cycle after the first transition		$T_{STEADY}$	-	-	1.4	ms
Clock startup time after the de-assertion of SuspendM	Peripheral	$T_{START\_DEV}$	-	-	5.6	ms
	Host	$T_{START\_HOST}$	-	-	-	
PHY preparation time after the first transition of the input clock		$T_{PREP}$	-	-	-	$\mu\text{s}$

1. Guaranteed by design, not tested in production.

Figure 45. ULPI timing diagram

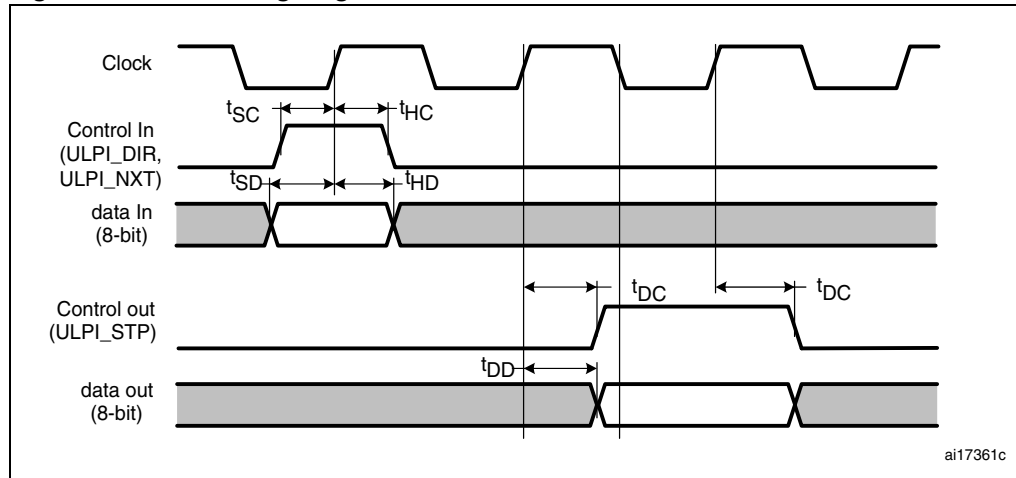


Table 57. ULPI timing

Parameter	Symbol	Value <sup>(1)</sup>		Unit
		Min.	Max.	
Control in (ULPI_DIR) setup time	$t_{SC}$	-	2.0	ns
Control in (ULPI_NXT) setup time		-	1.5	
Control in (ULPI_DIR, ULPI_NXT) hold time	$t_{HC}$	-	-	
Data in setup time	$t_{SD}$	-	2.0	
Data in hold time	$t_{HD}$	0	-	
Control out (ULPI_STP) setup time and hold time	$t_{DC}$	-	9.2	
Data out available from clock rising edge	$t_{DD}$	-	10.7	

1.  $V_{DD} = 2.7\text{ V to }3.6\text{ V}$  and  $T_A = -40\text{ to }85\text{ }^\circ\text{C}$ .

Ethernet characteristics

Table 58 shows the Ethernet operating voltage.

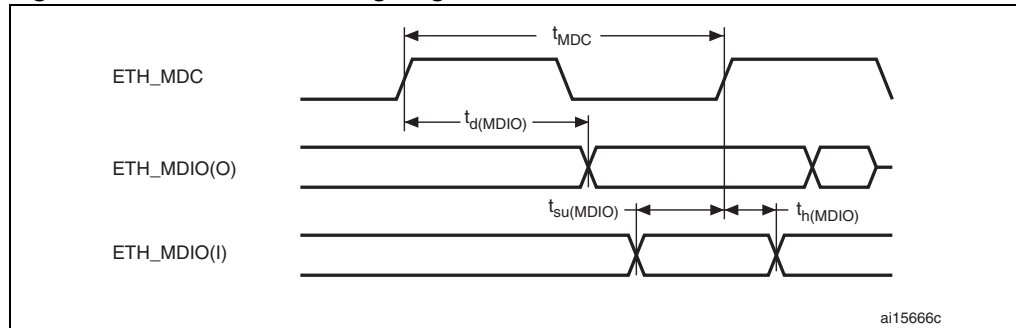
Table 58. Ethernet DC electrical characteristics

Symbol	Parameter	Min. <sup>(1)</sup>	Max. <sup>(1)</sup>	Unit
Input level $V_{DD}$	Ethernet operating voltage	2.7	3.6	V

1. All the voltages are measured from the local ground potential.

Table 59 gives the list of Ethernet MAC signals for the SMI (station management interface) and Figure 46 shows the corresponding timing diagram.

**Figure 46. Ethernet SMI timing diagram**



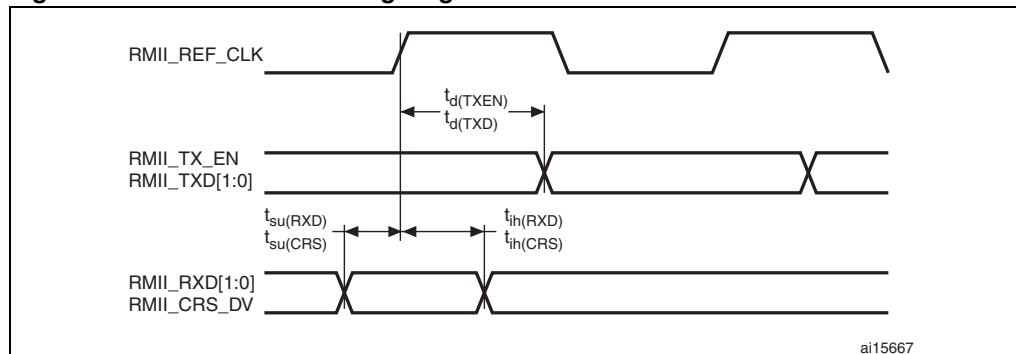
**Table 59. Dynamics characteristics: Ethernet MAC signals for SMI<sup>(1)</sup>**

Symbol	Rating	Min	Typ	Max	Unit
$t_{MDC}$	MDC cycle time (2.38 MHz, AHB = 60 MHz)	411	420	425	ns
$t_{d(MDIO)}$	MDIO write data valid time	6	10	13	ns
$t_{su(MDIO)}$	Read data setup time	TBD	TBD	TBD	ns
$t_{h(MDIO)}$	Read data hold time	TBD	TBD	TBD	ns

1. TBD stands for "to be defined".

Table 60 gives the list of Ethernet MAC signals for the RMII and Figure 47 shows the corresponding timing diagram.

**Figure 47. Ethernet RMII timing diagram**



**Table 60. Dynamics characteristics: Ethernet MAC signals for RMII**

Symbol	Rating	Min	Typ	Max	Unit
$t_{su(RXD)}$	Receive data setup time	1	-	4	ns
$t_{h(RXD)}$	Receive data hold time	1.5	-	2	ns
$t_{su(CRS)}$	Carrier sense set-up time	0	-	4	ns
$t_{h(CRS)}$	Carrier sense hold time	2	-	2	ns
$t_{d(TXEN)}$	Transmit enable valid delay time	9	11	13	ns
$t_{d(TXD)}$	Transmit data valid delay time	9	11.5	14	ns

Table 61 gives the list of Ethernet MAC signals for MII and Figure 47 shows the corresponding timing diagram.

Figure 48. Ethernet MII timing diagram

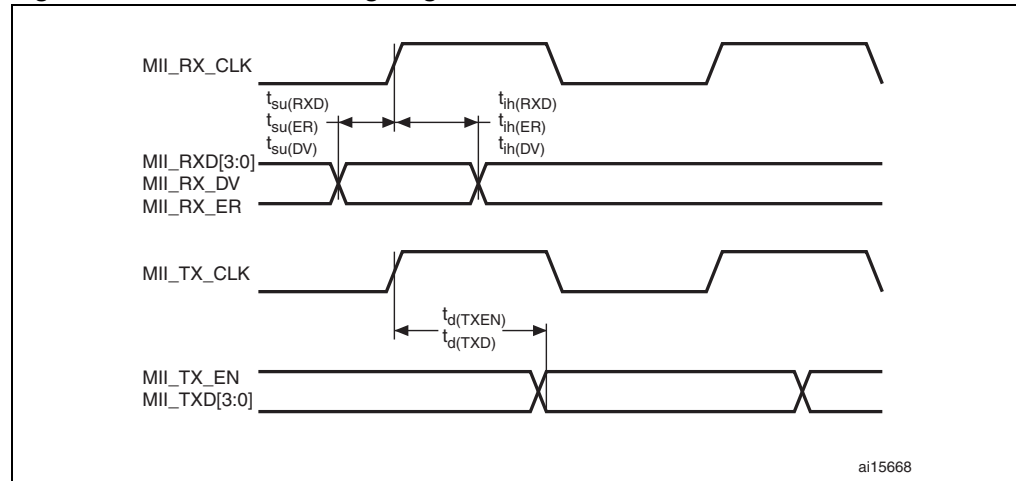


Table 61. Dynamics characteristics: Ethernet MAC signals for MII<sup>(1)</sup>

Symbol	Rating	Min	Typ	Max	Unit
$t_{su}(RXD)$	Receive data setup time	7.5	-	10	ns
$t_{ih}(RXD)$	Receive data hold time	1	-	10	ns
$t_{su}(DV)$	Data valid setup time	4	-	10	ns
$t_{ih}(DV)$	Data valid hold time	0	-	10	ns
$t_{su}(ER)$	Error setup time	3.5	-	10	ns
$t_{ih}(ER)$	Error hold time	0	-	10	ns
$t_d(TXEN)$	Transmit enable valid delay time	7.5	11	14	ns
$t_d(TXD)$	Transmit data valid delay time	7.5	11	14	ns

1. TBD stands for "to be defined".

### CAN (controller area network) interface

Refer to [Section 5.3.16: I/O port characteristics](#) for more details on the input/output alternate function characteristics (CANTX and CANRX).



### 5.3.20 12-bit ADC characteristics

Unless otherwise specified, the parameters given in [Table 62](#) are derived from tests performed under the ambient temperature,  $f_{PCLK2}$  frequency and  $V_{DDA}$  supply voltage conditions summarized in [Table 10](#).

**Table 62. ADC characteristics<sup>(1)</sup>**

Symbol	Parameter	Conditions	Min	Typ	Max	Unit
$V_{DDA}$	Power supply		1.8	-	3.6	V
$V_{REF+}$	Positive reference voltage		1.8 <sup>(2)</sup>	-	$V_{DDA}$	V
$f_{ADC}$	ADC clock frequency	$V_{DDA} = 1.8$ to $2.4$ V	0.6	-	15	MHz
		$V_{DDA} = 2.4$ to $3.6$ V	0.6	-	30	MHz
$f_{TRIG}^{(3)}$	External trigger frequency	$f_{ADC} = 30$ MHz	-	-	823	kHz
			-	-	17	$1/f_{ADC}$
$V_{AIN}$	Conversion voltage range <sup>(4)</sup>		0 ( $V_{SSA}$ or $V_{REF-}$ tied to ground)	-	$V_{REF+}$	V
$R_{AIN}^{(3)}$	External input impedance	See <a href="#">Equation 1</a> for details	-	-	50	k $\Omega$
$R_{ADC}^{(3)(5)}$	Sampling switch resistance		1.5	-	6	k $\Omega$
$C_{ADC}^{(3)}$	Internal sample and hold capacitor		4	-	TBD	pF
$t_{lat}^{(3)}$	Injection trigger conversion latency	$f_{ADC} = 30$ MHz	-	-	0.100	$\mu$ s
			-	-	3 <sup>(6)</sup>	$1/f_{ADC}$
$t_{latr}^{(3)}$	Regular trigger conversion latency	$f_{ADC} = 30$ MHz	-	-	0.067	$\mu$ s
			-	-	2 <sup>(6)</sup>	$1/f_{ADC}$
$t_S^{(3)}$	Sampling time	$f_{ADC} = 30$ MHz	0.100	-	16	$\mu$ s
			3	-	480	$1/f_{ADC}$
$t_{STAB}^{(3)}$	Power-up time		-	2	3	$\mu$ s
$t_{CONV}^{(3)}$	Total conversion time (including sampling time)	$f_{ADC} = 30$ MHz 12-bit resolution	0.5	-	16.40	$\mu$ s
		$f_{ADC} = 30$ MHz 10-bit resolution	0.43	-	16.34	$\mu$ s
		$f_{ADC} = 30$ MHz 8-bit resolution	0.37	-	16.27	$\mu$ s
		$f_{ADC} = 30$ MHz 6-bit resolution	0.3	-	16.20	$\mu$ s
		9 to 492 ( $t_S$ for sampling +n-bit resolution for successive approximation)				

Table 62. ADC characteristics<sup>(1)</sup> (continued)

Symbol	Parameter	Conditions	Min	Typ	Max	Unit
$f_S^{(3)}$	Sampling rate ( $f_{ADC} = 30$ MHz)	12-bit resolution Single ADC	-	-	2	MspS
		12-bit resolution Interleave Dual ADC mode	-	-	3.75	MspS
		12-bit resolution Interleave Triple ADC mode	-	-	6	MspS
$I_{VREF+}^{(3)}$	ADC $V_{REF+}$ DC current consumption in conversion mode	$f_{ADC} = 30$ MHz 3 sampling time 12-bit resolution	-	300	500	$\mu$ A
		$f_{ADC} = 30$ MHz 480 sampling time 12-bit resolution	-	-	TBD	$\mu$ A
$I_{DDA}^{(3)}$	ADC $V_{DDA}$ DC current consumption in conversion mode	$f_{ADC} = 30$ MHz 3 sampling time 12-bit resolution	-	1.6	1.8	mA
		$f_{ADC} = 30$ MHz 480 sampling time 12-bit resolution	-	-	TBD	

1. TBD stands for "to be defined".
2. It is recommended to maintain the voltage difference between  $V_{REF+}$  and  $V_{DDA}$  below 1.8 V.
3. Based on characterization, not tested in production.
4.  $V_{REF+}$  is internally connected to  $V_{DDA}$  and  $V_{REF-}$  is internally connected to  $V_{SSA}$ .
5.  $R_{ADC}$  maximum value is given for  $V_{DD}=1.8$  V, and minimum value for  $V_{DD}=3.3$  V.
6. For external triggers, a delay of  $1/f_{PCLK2}$  must be added to the latency specified in [Table 62](#).

**Equation 1:  $R_{AIN}$  max formula**

$$R_{AIN} = \frac{(k - 0.5)}{f_{ADC} \times C_{ADC} \times \ln(2^{N+2})} - R_{ADC}$$

The formula above ([Equation 1](#)) is used to determine the maximum external impedance allowed for an error below 1/4 of LSB.  $N = 12$  (from 12-bit resolution) and  $k$  is the number of sampling periods defined in the `ADC_SMPR1` register.

**Table 63. ADC accuracy <sup>(1)</sup>**

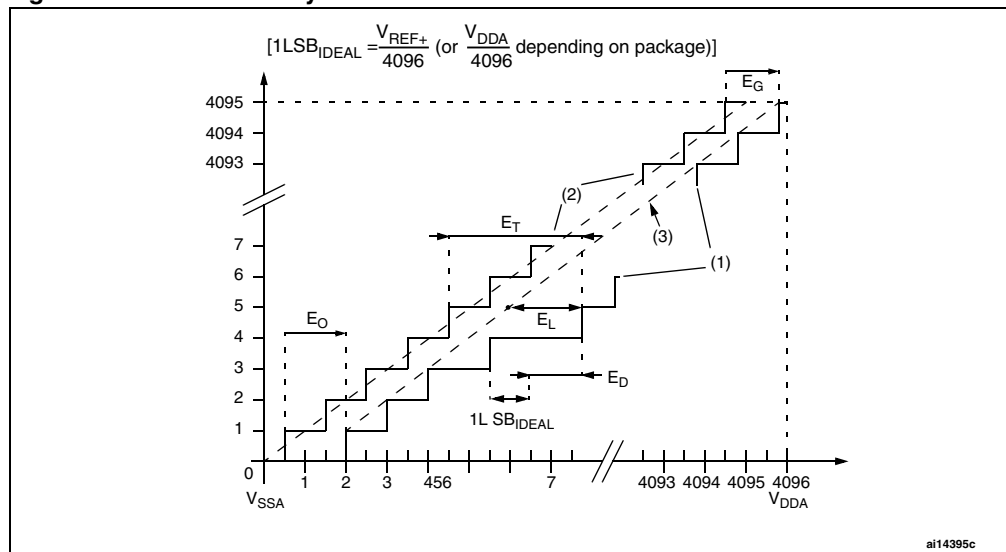
Symbol	Parameter	Test conditions	Typ	Max <sup>(2)</sup>	Unit
ET	Total unadjusted error	$f_{PCLK2} = 60 \text{ MHz}$ , $f_{ADC} = 30 \text{ MHz}$ , $R_{AIN} < 10 \text{ k}\Omega$ , $V_{DDA} = 1.8 \text{ to } 3.6 \text{ V}$	±2	±5	LSB
EO	Offset error		±1.5	±2.5	
EG	Gain error		±1.5	±3	
ED	Differential linearity error		±1	±2	
EL	Integral linearity error		±1.5	±3	

1. Better performance could be achieved in restricted  $V_{DD}$ , frequency and temperature ranges.
2. Based on characterization, not tested in production.

**Note:** ADC accuracy vs. negative injection current: Injecting a negative current on any of the standard (non-robust) analog input pins should be avoided as this significantly reduces the accuracy of the conversion being performed on another analog input. It is recommended to add a Schottky diode (pin to ground) to standard analog pins which may potentially inject negative currents.

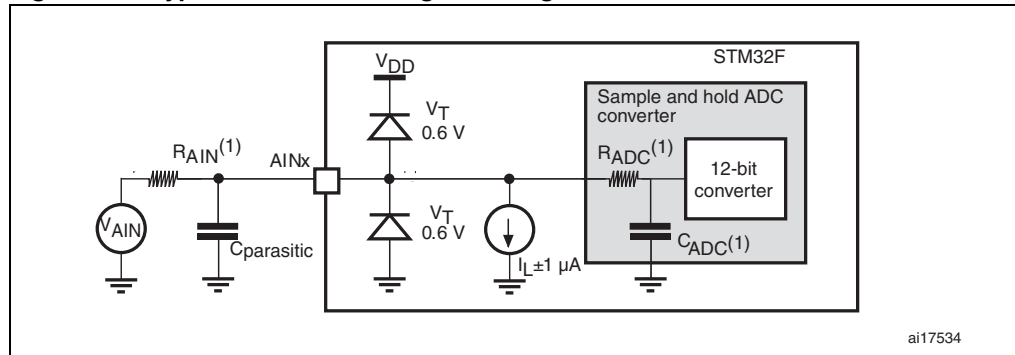
Any positive injection current within the limits specified for  $I_{INJ(PIN)}$  and  $\Sigma I_{INJ(PIN)}$  in [Section 5.3.16](#) does not affect the ADC accuracy.

**Figure 49. ADC accuracy characteristics**



1. Example of an actual transfer curve.
2. Ideal transfer curve.
3. End point correlation line.
4.  $E_T$  = Total Unadjusted Error: maximum deviation between the actual and the ideal transfer curves.  
 $E_O$  = Offset Error: deviation between the first actual transition and the first ideal one.  
 $E_G$  = Gain Error: deviation between the last ideal transition and the last actual one.  
 $E_D$  = Differential Linearity Error: maximum deviation between actual steps and the ideal one.  
 $E_L$  = Integral Linearity Error: maximum deviation between any actual transition and the end point correlation line.

Figure 50. Typical connection diagram using the ADC

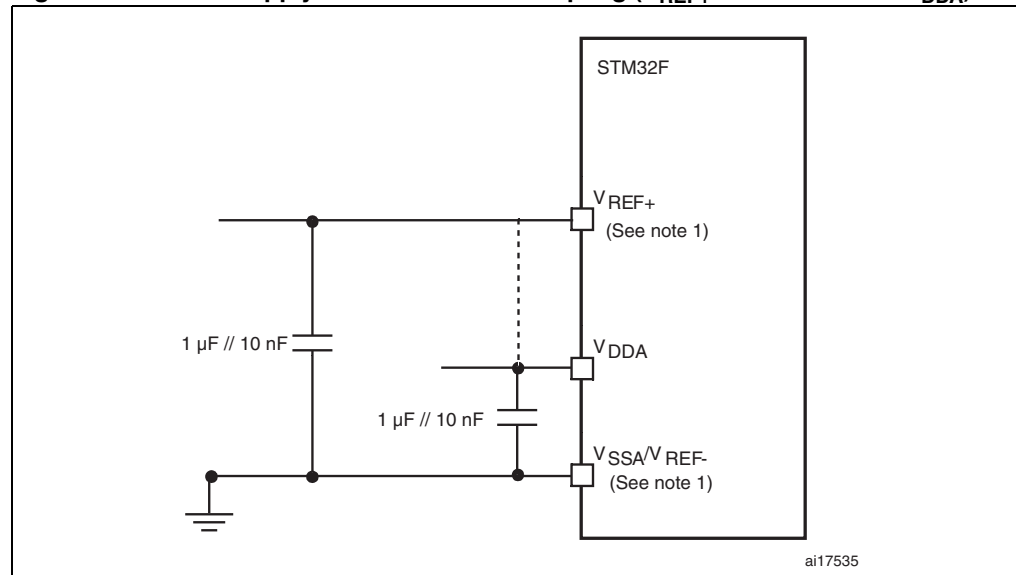


1. Refer to [Table 62](#) for the values of  $R_{AIN}$ ,  $R_{ADC}$  and  $C_{ADC}$ .
2.  $C_{parasitic}$  represents the capacitance of the PCB (dependent on soldering and PCB layout quality) plus the pad capacitance (roughly 7 pF). A high  $C_{parasitic}$  value downgrades conversion accuracy. To remedy this,  $f_{ADC}$  should be reduced.

### General PCB design guidelines

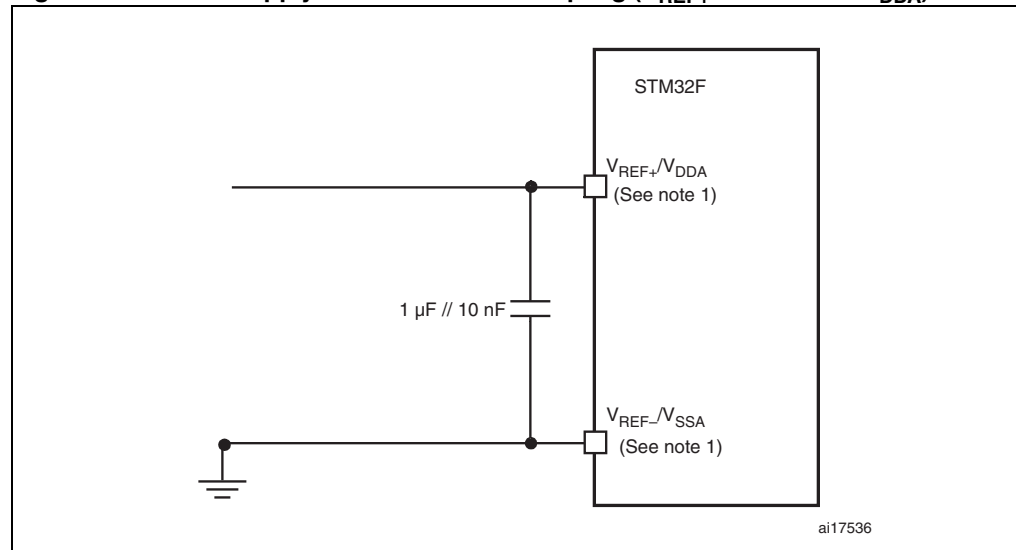
Power supply decoupling should be performed as shown in [Figure 51](#) or [Figure 52](#), depending on whether  $V_{REF+}$  is connected to  $V_{DDA}$  or not. The 10 nF capacitors should be ceramic (good quality). They should be placed them as close as possible to the chip.

**Figure 51. Power supply and reference decoupling ( $V_{REF+}$  not connected to  $V_{DDA}$ )**



1.  $V_{REF+}$  and  $V_{REF-}$  inputs are available only on 100-pin packages.

**Figure 52. Power supply and reference decoupling ( $V_{REF+}$  connected to  $V_{DDA}$ )**



1.  $V_{REF+}$  and  $V_{REF-}$  inputs are available only on 100-pin packages.

## 5.3.21 DAC electrical characteristics

Table 64. DAC characteristics

Symbol	Parameter	Min	Typ	Max	Unit	Comments
$V_{DDA}$	Analog supply voltage	1.8	-	3.6	V	
$V_{REF+}$	Reference supply voltage	1.8	-	3.6	V	$V_{REF+} \leq V_{DDA}$
$V_{SSA}$	Ground	0	-	0	V	
$R_{LOAD}^{(1)}$	Resistive load with buffer ON	5	-	-	k $\Omega$	
$R_O^{(1)}$	Impedance output with buffer OFF	-	-	15	k $\Omega$	When the buffer is OFF, the Minimum resistive load between DAC_OUT and $V_{SS}$ to have a 1% accuracy is 1.5 M $\Omega$
$C_{LOAD}^{(1)}$	Capacitive load	-	-	50	pF	Maximum capacitive load at DAC_OUT pin (when the buffer is ON).
DAC_OUT min <sup>(1)</sup>	Lower DAC_OUT voltage with buffer ON	0.2	-	-	V	It gives the maximum output excursion of the DAC. It corresponds to 12-bit input code (0x0E0) to (0xF1C) at $V_{REF+} = 3.6$ V and (0x1C7) to (0xE38) at $V_{REF+} = 1.8$ V
DAC_OUT max <sup>(1)</sup>	Higher DAC_OUT voltage with buffer ON	-	-	$V_{DDA} - 0.2$	V	
DAC_OUT min <sup>(1)</sup>	Lower DAC_OUT voltage with buffer OFF	-	0.5	-	mV	It gives the maximum output excursion of the DAC.
DAC_OUT max <sup>(1)</sup>	Higher DAC_OUT voltage with buffer OFF	-	-	$V_{REF+} - 1LSB$	V	
$I_{VREF+}^{(2)}$	DAC DC $V_{REF}$ current consumption in quiescent mode (Standby mode)	-	170	240	$\mu$ A	With no load, worst code (0x800) at $V_{REF+} = 3.6$ V in terms of DC consumption on the inputs
		-	50	75		With no load, worst code (0xF1C) at $V_{REF+} = 3.6$ V in terms of DC consumption on the inputs
$I_{DDA}^{(2)}$	DAC DC $V_{DDA}$ current consumption in quiescent mode (Standby mode)	-	280	380	$\mu$ A	With no load, middle code (0x800) on the inputs
		-	475	625	$\mu$ A	With no load, worst code (0xF1C) at $V_{REF+} = 3.6$ V in terms of DC consumption on the inputs
DNL <sup>(2)</sup>	Differential non linearity Difference between two consecutive code-1LSB)	-	-	$\pm 0.5$	LSB	Given for the DAC in 10-bit configuration.
		-	-	$\pm 2$	LSB	Given for the DAC in 12-bit configuration.

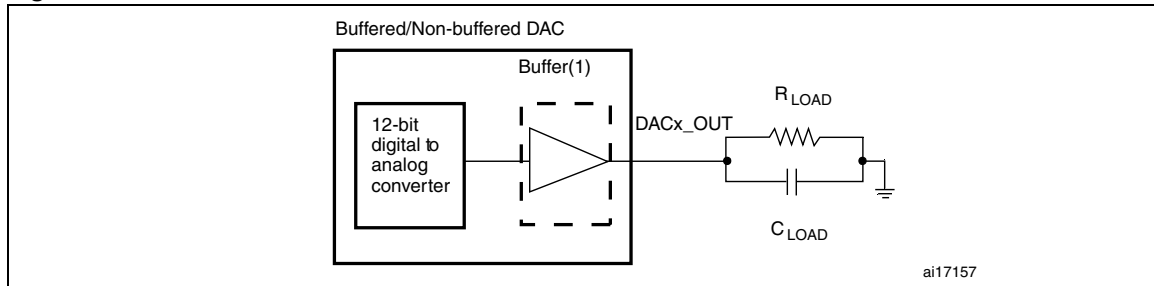
Table 64. DAC characteristics (continued)

Symbol	Parameter	Min	Typ	Max	Unit	Comments
INL <sup>(2)</sup>	Integral non linearity (difference between measured value at Code i and the value at Code i on a line drawn between Code 0 and last Code 1023)	-	-	±1	LSB	Given for the DAC in 10-bit configuration.
		-	-	±4	LSB	Given for the DAC in 12-bit configuration.
Offset <sup>(2)</sup>	Offset error (difference between measured value at Code (0x800) and the ideal value = $V_{REF+}/2$ )	-	-	±10	mV	Given for the DAC in 12-bit configuration
		-	-	±3	LSB	Given for the DAC in 10-bit at $V_{REF+} = 3.6$ V
		-	-	±12	LSB	Given for the DAC in 12-bit at $V_{REF+} = 3.6$ V
Gain error <sup>(2)</sup>	Gain error	-	-	±0.5	%	Given for the DAC in 12-bit configuration
t <sub>SETTLING</sub> <sup>(2)</sup>	Settling time (full scale: for a 10-bit input code transition between the lowest and the highest input codes when DAC_OUT reaches final value ±4LSB)	-	3	6	µs	$C_{LOAD} \leq 50$ pF, $R_{LOAD} \geq 5$ kΩ
THD <sup>(2)</sup>	Total Harmonic Distortion Buffer ON	-	-	-	dB	$C_{LOAD} \leq 50$ pF, $R_{LOAD} \geq 5$ kΩ
Update rate <sup>(1)</sup>	Max frequency for a correct DAC_OUT change when small variation in the input code (from code i to i+1LSB)	-	-	1	MS/s	$C_{LOAD} \leq 50$ pF, $R_{LOAD} \geq 5$ kΩ
t <sub>WAKEUP</sub> <sup>(2)</sup>	Wakeup time from off state (Setting the ENx bit in the DAC Control register)	-	6.5	10	µs	$C_{LOAD} \leq 50$ pF, $R_{LOAD} \geq 5$ kΩ input code between lowest and highest possible ones.
PSRR <sup>+</sup> <sup>(1)</sup>	Power supply rejection ratio (to V <sub>DDA</sub> ) (static DC measurement)	-	-67	-40	dB	No R <sub>LOAD</sub> , C <sub>LOAD</sub> = 50 pF

1. Guaranteed by design, not tested in production.

2. Guaranteed by characterization, not tested in production.

Figure 53. 12-bit buffered /non-buffered DAC



1. The DAC integrates an output buffer that can be used to reduce the output impedance and to drive external loads directly without the use of an external operational amplifier. The buffer can be bypassed by configuring the BOFFx bit in the DAC\_CR register.

### 5.3.22 Temperature sensor characteristics

Table 65. TS characteristics

Symbol	Parameter	Min	Typ	Max	Unit
$T_L^{(1)}$	$V_{SENSE}$ linearity with temperature	-	$\pm 1$	$\pm 2$	$^{\circ}\text{C}$
Avg_Slope <sup>(1)</sup>	Average slope	-	2.5		mV/ $^{\circ}\text{C}$
$V_{25}^{(1)}$	Voltage at 25 $^{\circ}\text{C}$	-	0.76		V
$t_{START}^{(2)}$	Startup time	-	6	10	$\mu\text{s}$
$T_{S\_temp}^{(3)(2)}$	ADC sampling time when reading the temperature 1 $^{\circ}\text{C}$ accuracy	10	-	-	$\mu\text{s}$

1. Based on characterization, not tested in production.
2. Guaranteed by design, not tested in production.
3. Shortest sampling time can be determined in the application by multiple iterations.

### 5.3.23 $V_{BAT}$ monitoring characteristics

Table 66.  $V_{BAT}$  monitoring characteristics

Symbol	Parameter	Min	Typ	Max	Unit
R	Resistor bridge for $V_{BAT}$	-	50	-	K $\Omega$
Q	Ratio on $V_{BAT}$ measurement	-	2	-	
$E_r^{(1)}$	Error on Q	-1	-	+1	%
$T_{S\_vbat}^{(2)(2)}$	ADC sampling time when reading the $V_{BAT}$ 1mV accuracy	5	-	-	$\mu\text{s}$

1. Guaranteed by design, not tested in production.
2. Shortest sampling time can be determined in the application by multiple iterations.



### 5.3.24 Embedded reference voltage

The parameters given in [Table 67](#) are derived from tests performed under ambient temperature and  $V_{DD}$  supply voltage conditions summarized in [Table 10](#).

**Table 67. Embedded internal reference voltage**

Symbol	Parameter	Conditions	Min	Typ	Max	Unit
$V_{REFINT}$	Internal reference voltage	$-40\text{ °C} < T_A < +105\text{ °C}$	1.18	1.21	1.24	V
$T_{S\_vrefint}^{(1)}$	ADC sampling time when reading the internal reference voltage		10	-	-	$\mu\text{s}$
$V_{REFINT\_s}^{(2)}$	Internal reference voltage spread over the temperature range	$V_{DD} = 3\text{ V}$	-	3	5	mV
$T_{Coeff}^{(2)}$	Temperature coefficient		-	30	50	ppm/°C
$t_{START}^{(2)}$	Startup time		-	6	10	$\mu\text{s}$

1. Shortest sampling time can be determined in the application by multiple iterations.
2. Guaranteed by design, not tested in production.

### 5.3.25 FSMC characteristics

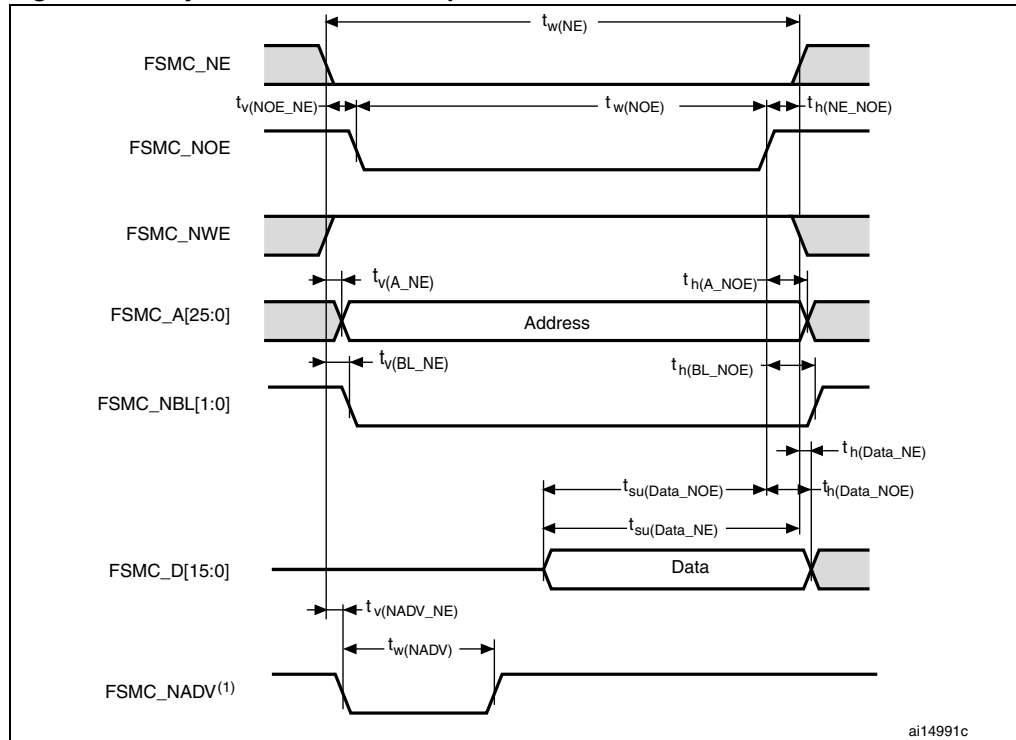
#### Asynchronous waveforms and timings

[Figure 54](#) through [Figure 57](#) represent asynchronous waveforms and [Table 68](#) through [Table 71](#) provide the corresponding timings. The results shown in these tables are obtained with the following FSMC configuration:

- AddressSetupTime = 1
- AddressHoldTime = 1
- DataSetupTime = 1
- BusTurnAroundDuration = 0x0

In all timing tables, the  $T_{HCLK}$  is the HCLK clock period.

Figure 54. Asynchronous non-multiplexed SRAM/PSRAM/NOR read waveforms



1. Mode 2/B, C and D only. In Mode 1, FSMC\_NADV is not used.

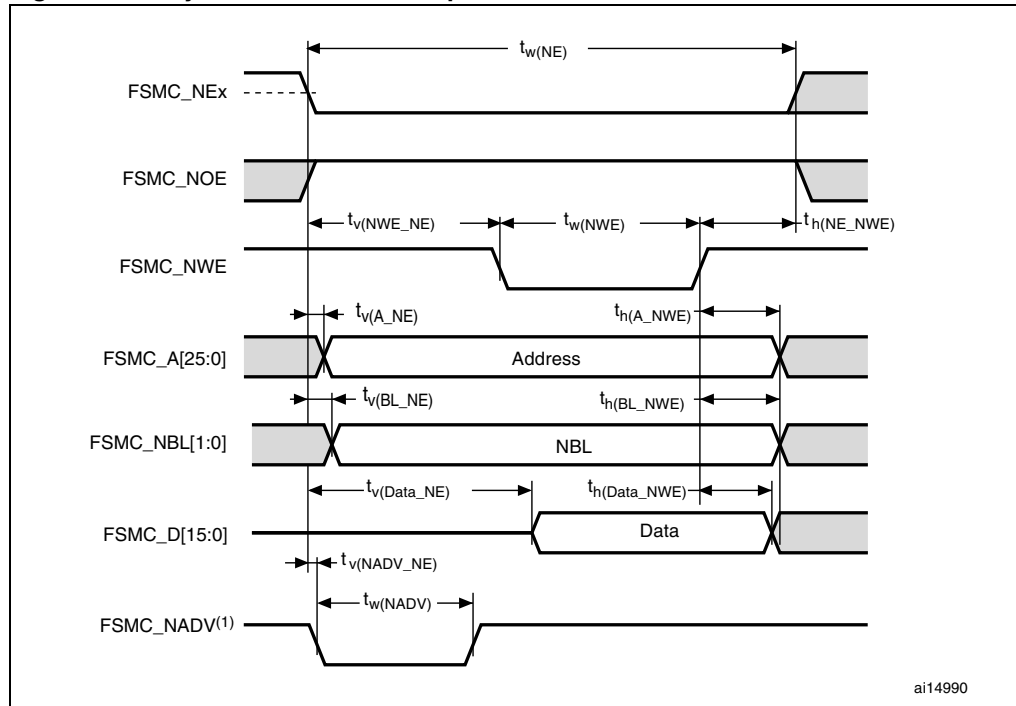
Table 68. Asynchronous non-multiplexed SRAM/PSRAM/NOR read timings<sup>(1)(2)</sup>

Symbol	Parameter	Min	Max	Unit
$t_{w(NE)}$	FSMC_NE low time	$2T_{HCLK} - 0.5$	$2T_{HCLK} + 0.5$	ns
$t_{v(NOE\_NE)}$	FSMC_NEx low to FSMC_NOE low	0.5	2.5	ns
$t_{w(NOE)}$	FSMC_NOE low time	$2T_{HCLK} - 1$	$2T_{HCLK} + 0.5$	ns
$t_{h(NE\_NOE)}$	FSMC_NOE high to FSMC_NE high hold time	0	-	ns
$t_{v(A\_NE)}$	FSMC_NEx low to FSMC_A valid	-	4	ns
$t_{h(A\_NOE)}$	Address hold time after FSMC_NOE high	0	-	ns
$t_{v(BL\_NE)}$	FSMC_NEx low to FSMC_BL valid	-	0.5	ns
$t_{h(BL\_NOE)}$	FSMC_BL hold time after FSMC_NOE high	0	-	ns
$t_{su(Data\_NE)}$	Data to FSMC_NEx high setup time	$T_{HCLK} + 0.5$	-	ns
$t_{su(Data\_NOE)}$	Data to FSMC_NOEx high setup time	$T_{HCLK} + 2.5$	-	ns
$t_{h(Data\_NOE)}$	Data hold time after FSMC_NOE high	0	-	ns
$t_{h(Data\_NE)}$	Data hold time after FSMC_NEx high	0	-	ns
$t_{v(NADV\_NE)}$	FSMC_NEx low to FSMC_NADV low	-	2.5	ns
$t_{w(NADV)}$	FSMC_NADV low time	-	$T_{HCLK} - 0.5$	ns

1.  $C_L = 30$  pF.

2. Based on characterization, not tested in production.

Figure 55. Asynchronous non-multiplexed SRAM/PSRAM/NOR write waveforms



1. Mode 2/B, C and D only. In Mode 1, FSMC\_NADV is not used.

Table 69. Asynchronous non-multiplexed SRAM/PSRAM/NOR write timings<sup>(1)(2)</sup>

Symbol	Parameter	Min	Max	Unit
$t_{w(NE)}$	FSMC_NE low time	$3T_{HCLK}$	$3T_{HCLK} + 4$	ns
$t_{v(NWE\_NE)}$	FSMC_NEx low to FSMC_NWE low	$T_{HCLK} - 0.5$	$T_{HCLK} + 0.5$	ns
$t_{w(NWE)}$	FSMC_NWE low time	$T_{HCLK} - 0.5$	$T_{HCLK} + 3$	ns
$t_{h(NE\_NWE)}$	FSMC_NWE high to FSMC_NE high hold time	$T_{HCLK}$	-	ns
$t_{v(A\_NE)}$	FSMC_NEx low to FSMC_A valid	-	0	ns
$t_{h(A\_NWE)}$	Address hold time after FSMC_NWE high	$T_{HCLK} - 3$	-	ns
$t_{v(BL\_NE)}$	FSMC_NEx low to FSMC_BL valid	-	0.5	ns
$t_{h(BL\_NWE)}$	FSMC_BL hold time after FSMC_NWE high	$T_{HCLK} - 1$	-	ns
$t_{v(Data\_NE)}$	Data to FSMC_NEx low to Data valid	-	$T_{HCLK} + 5$	ns
$t_{h(Data\_NWE)}$	Data hold time after FSMC_NWE high	$T_{HCLK} + 0.5$	-	ns
$t_{v(NADV\_NE)}$	FSMC_NEx low to FSMC_NADV low	-	2	ns
$t_{w(NADV)}$	FSMC_NADV low time	-	$T_{HCLK} + 1.5$	ns

1.  $C_L = 30$  pF.

2. Based on characterization, not tested in production.

Figure 56. Asynchronous multiplexed PSRAM/NOR read waveforms

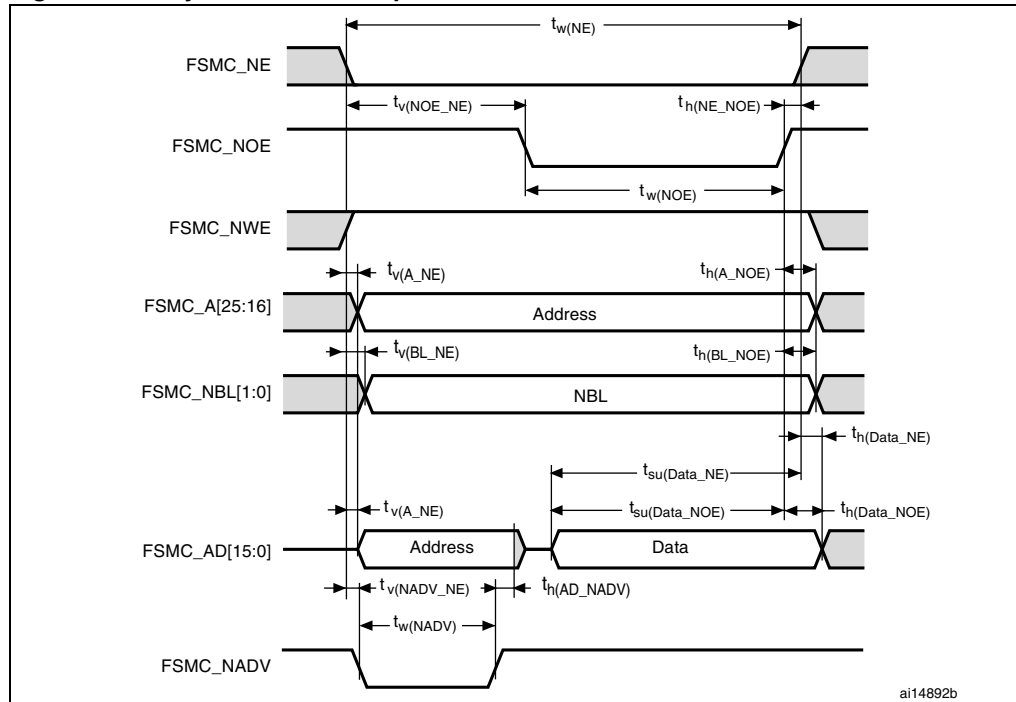
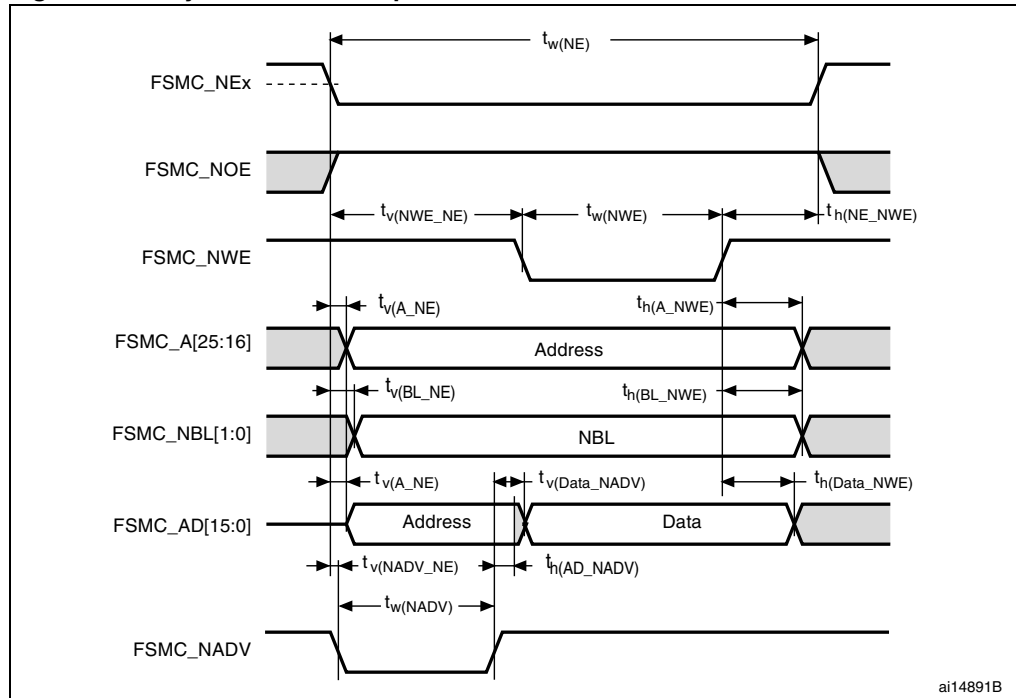


Table 70. Asynchronous multiplexed PSRAM/NOR read timings<sup>(1)(2)</sup>

Symbol	Parameter	Min	Max	Unit
$t_{w(NE)}$	FSMC_NE low time	$3T_{HCLK}-1$	$3T_{HCLK}+1$	ns
$t_{v(NOE\_NE)}$	FSMC_NEx low to FSMC_NOE low	$2T_{HCLK}$	$2T_{HCLK}+0.5$	ns
$t_{w(NOE)}$	FSMC_NOE low time	$T_{HCLK}-1$	$T_{HCLK}+1$	ns
$t_{h(NE\_NOE)}$	FSMC_NOE high to FSMC_NE high hold time	0	-	ns
$t_{v(A\_NE)}$	FSMC_NEx low to FSMC_A valid	-	2	ns
$t_{v(NADV\_NE)}$	FSMC_NEx low to FSMC_NADV low	1	2.5	ns
$t_{w(NADV)}$	FSMC_NADV low time	$T_{HCLK}-1.5$	$T_{HCLK}$	ns
$t_{h(AD\_NADV)}$	FSMC_AD(address) valid hold time after FSMC_NADV high	$T_{HCLK}$	-	ns
$t_{h(A\_NOE)}$	Address hold time after FSMC_NOE high	$T_{HCLK}$	-	ns
$t_{h(BL\_NOE)}$	FSMC_BL time after FSMC_NOE high	0	-	ns
$t_{v(BL\_NE)}$	FSMC_NEx low to FSMC_BL valid	-	1	ns
$t_{su(Data\_NE)}$	Data to FSMC_NEx high setup time	$T_{HCLK}+2$	-	ns
$t_{su(Data\_NOE)}$	Data to FSMC_NOE high setup time	$T_{HCLK}+3$	-	ns
$t_{h(Data\_NE)}$	Data hold time after FSMC_NEx high	0	-	ns
$t_{h(Data\_NOE)}$	Data hold time after FSMC_NOE high	0	-	ns

1.  $C_L = 30$  pF.
2. Based on characterization, not tested in production.

Figure 57. Asynchronous multiplexed PSRAM/NOR write waveforms



ai14891B

Table 71. Asynchronous multiplexed PSRAM/NOR write timings<sup>(1)(2)</sup>

Symbol	Parameter	Min	Max	Unit
$t_{w(NE)}$	FSMC_NE low time	$4T_{HCLK}-1$	$4T_{HCLK}+1$	ns
$t_{v(NWE\_NE)}$	FSMC_NEx low to FSMC_NWE low	$T_{HCLK}-1$	$T_{HCLK}$	ns
$t_{w(NWE)}$	FSMC_NWE low time	$2T_{HCLK}$	$2T_{HCLK}+1$	ns
$t_{h(NE\_NWE)}$	FSMC_NWE high to FSMC_NE high hold time	$T_{HCLK}-1$	-	ns
$t_{v(A\_NE)}$	FSMC_NEx low to FSMC_A valid	-	0	ns
$t_{v(NADV\_NE)}$	FSMC_NEx low to FSMC_NADV low	1	2	ns
$t_{w(NADV)}$	FSMC_NADV low time	$T_{HCLK}-2$	$T_{HCLK}+2$	ns
$t_{h(AD\_NADV)}$	FSMC_AD(address) valid hold time after FSMC_NADV high	$T_{HCLK}$	-	ns
$t_{h(A\_NWE)}$	Address hold time after FSMC_NWE high	$T_{HCLK}-0.5$	-	ns
$t_{h(BL\_NWE)}$	FSMC_BL hold time after FSMC_NWE high	$T_{HCLK}-1$	-	ns
$t_{v(BL\_NE)}$	FSMC_NEx low to FSMC_BL valid	-	0.5	ns
$t_{v(Data\_NADV)}$	FSMC_NADV high to Data valid	-	$T_{HCLK}+2$	ns
$t_{h(Data\_NWE)}$	Data hold time after FSMC_NWE high	$T_{HCLK}-0.5$	-	ns

1.  $C_L = 30$  pF.
2. Based on characterization, not tested in production.

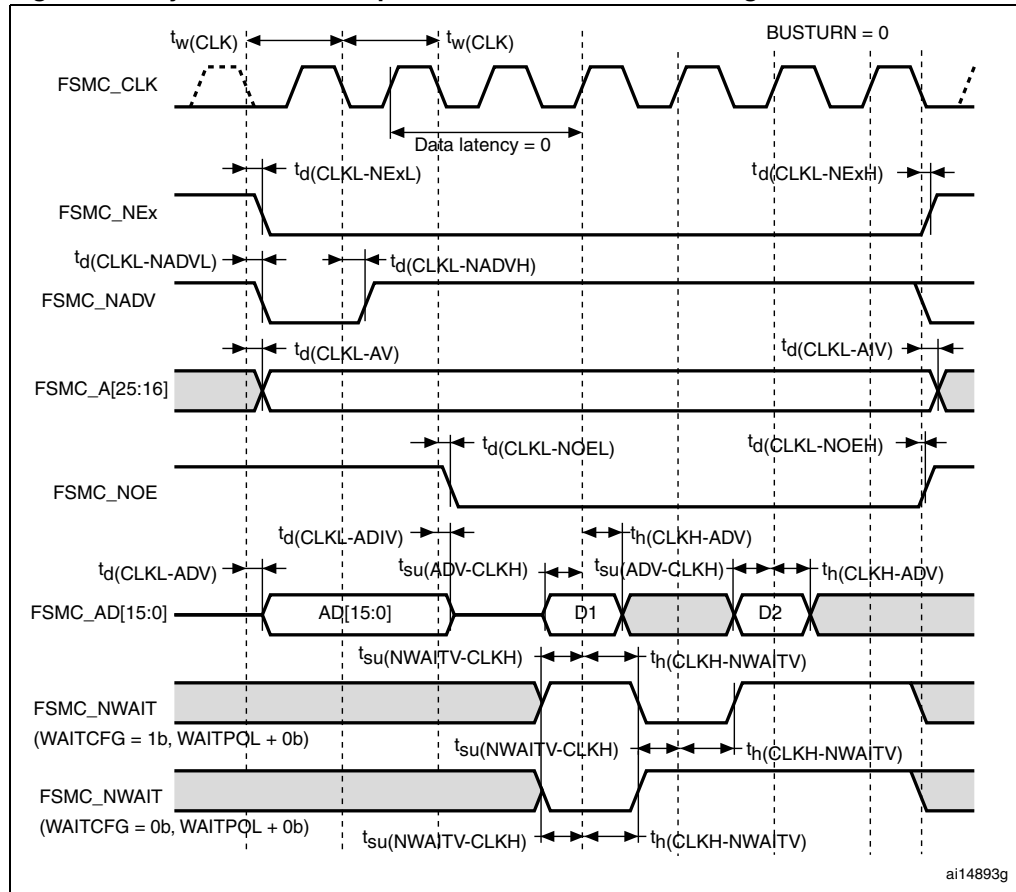
**Synchronous waveforms and timings**

Figure 58 through Figure 61 represent synchronous waveforms and Table 73 through Table 75 provide the corresponding timings. The results shown in these tables are obtained with the following FSMC configuration:

- BurstAccessMode = FSMC\_BurstAccessMode\_Enable;
- MemoryType = FSMC\_MemoryType\_CRAM;
- WriteBurst = FSMC\_WriteBurst\_Enable;
- CLKDivision = 1; (0 is not supported, see the STM32F20xxx/21xxx reference manual)
- DataLatency = 1 for NOR Flash; DataLatency = 0 for PSRAM

In all timing tables, the  $T_{HCLK}$  is the HCLK clock period.

**Figure 58. Synchronous multiplexed NOR/PSRAM read timings**



**Table 72. Synchronous multiplexed NOR/PSRAM read timings<sup>(1)(2)</sup>**

Symbol	Parameter	Min	Max	Unit
$t_{w(\text{CLK})}$	FSMC_CLK period	$2T_{\text{HCLK}}$	-	ns
$t_{d(\text{CLKL-NExL})}$	FSMC_CLK low to FSMC_NEx low (x=0..2)	-	0	ns
$t_{d(\text{CLKL-NExH})}$	FSMC_CLK low to FSMC_NEx high (x= 0...2)	1	-	ns
$t_{d(\text{CLKL-NADV})}$	FSMC_CLK low to FSMC_NADV low	-	1.5	ns
$t_{d(\text{CLKL-NADVH})}$	FSMC_CLK low to FSMC_NADV high	2.5	-	ns
$t_{d(\text{CLKL-AV})}$	FSMC_CLK low to FSMC_Ax valid (x=16...25)	-	0	ns
$t_{d(\text{CLKL-AIV})}$	FSMC_CLK low to FSMC_Ax invalid (x=16...25)	0	-	ns
$t_{d(\text{CLKL-NOEL})}$	FSMC_CLK low to FSMC_NOE low	-	1	ns
$t_{d(\text{CLKL-NOEH})}$	FSMC_CLK low to FSMC_NOE high	1	-	ns
$t_{d(\text{CLKL-ADV})}$	FSMC_CLK low to FSMC_AD[15:0] valid	-	3	ns
$t_{d(\text{CLKL-ADIV})}$	FSMC_CLK low to FSMC_AD[15:0] invalid	0	-	ns
$t_{su(\text{ADV-CLKH})}$	FSMC_A/D[15:0] valid data before FSMC_CLK high	5	-	ns
$t_{h(\text{CLKH-ADV})}$	FSMC_A/D[15:0] valid data after FSMC_CLK high	0	-	ns

1.  $C_L = 30$  pF.
2. Based on characterization, not tested in production.

Figure 59. Synchronous multiplexed PSRAM write timings

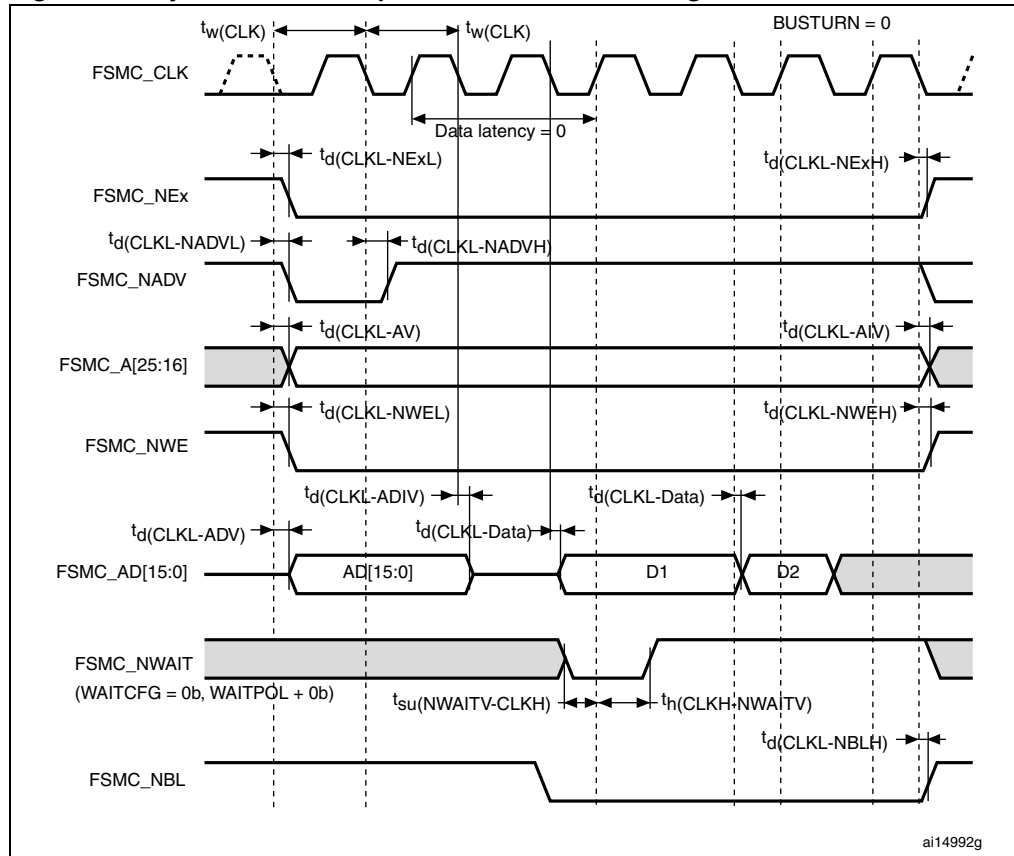


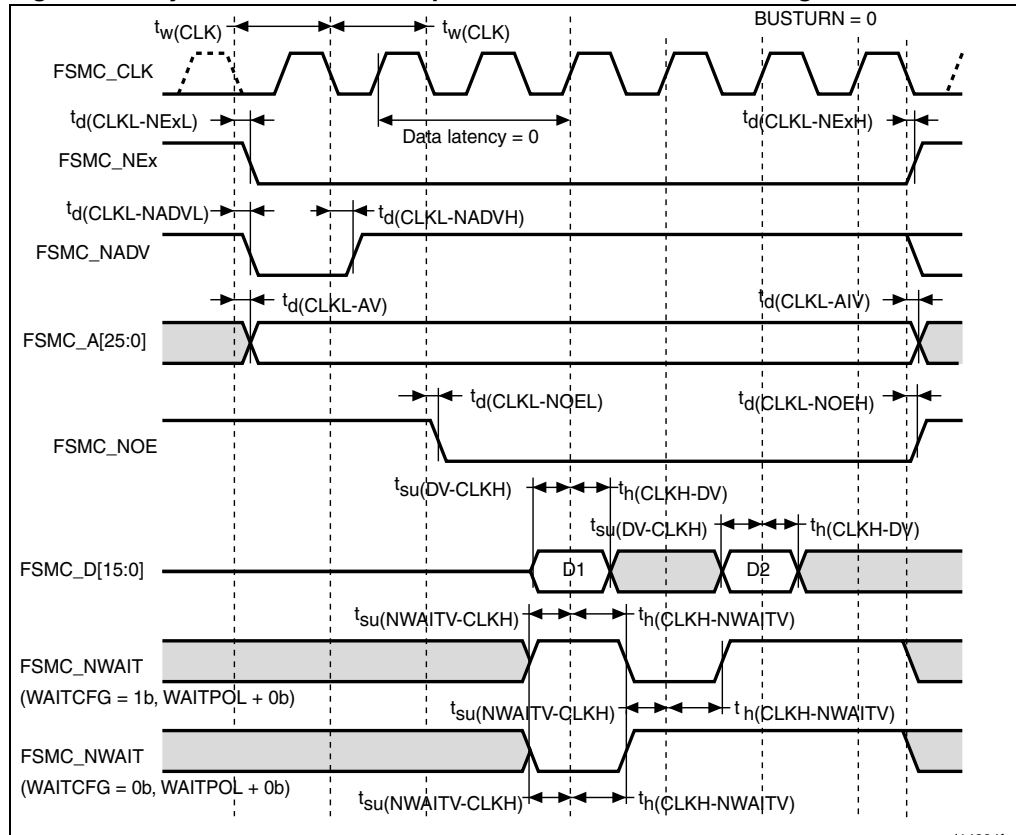
Table 73. Synchronous multiplexed PSRAM write timings<sup>(1)(2)</sup>

Symbol	Parameter	Min	Max	Unit
$t_w(\text{CLK})$	FSMC_CLK period	$2T_{\text{HCLK}} - 1$	-	ns
$t_d(\text{CLKL-NExL})$	FSMC_CLK low to FSMC_NEx low (x=0..2)	-	0	ns
$t_d(\text{CLKL-NExH})$	FSMC_CLK low to FSMC_NEx high (x= 0..2)	2	-	ns
$t_d(\text{CLKL-NADV})$	FSMC_CLK low to FSMC_NADV low	-	2	ns
$t_d(\text{CLKL-NADVH})$	FSMC_CLK low to FSMC_NADV high	3	-	ns
$t_d(\text{CLKL-AV})$	FSMC_CLK low to FSMC_Ax valid (x=16...25)	-	0	ns
$t_d(\text{CLKL-AIV})$	FSMC_CLK low to FSMC_Ax invalid (x=16...25)	7	-	ns
$t_d(\text{CLKL-NWEL})$	FSMC_CLK low to FSMC_NWE low	-	1	ns
$t_d(\text{CLKL-NWEH})$	FSMC_CLK low to FSMC_NWE high	0	-	ns
$t_d(\text{CLKL-ADIV})$	FSMC_CLK low to FSMC_AD[15:0] invalid	0	-	ns
$t_d(\text{CLKL-DATA})$	FSMC_A/D[15:0] valid data after FSMC_CLK low	-	2	ns
$t_d(\text{CLKL-NBLH})$	FSMC_CLK low to FSMC_NBL high	0.5	-	ns

1.  $C_L = 30$  pF.
2. Based on characterization, not tested in production.



**Figure 60. Synchronous non-multiplexed NOR/PSRAM read timings**



**Table 74. Synchronous non-multiplexed NOR/PSRAM read timings<sup>(1)(2)</sup>**

Symbol	Parameter	Min	Max	Unit
$t_w(\text{CLK})$	FSMC_CLK period	$2T_{\text{HCLK}}$	-	ns
$t_d(\text{CLKL-NExL})$	FSMC_CLK low to FSMC_NEx low ( $x=0..2$ )	-	0	ns
$t_d(\text{CLKL-NExH})$	FSMC_CLK low to FSMC_NEx high ( $x=0..2$ )	1	-	ns
$t_d(\text{CLKL-NADVl})$	FSMC_CLK low to FSMC_NADV low	-	2.5	ns
$t_d(\text{CLKL-NADVh})$	FSMC_CLK low to FSMC_NADV high	4	-	ns
$t_d(\text{CLKL-AV})$	FSMC_CLK low to FSMC_Ax valid ( $x=16..25$ )	-	0	ns
$t_d(\text{CLKL-AIV})$	FSMC_CLK low to FSMC_Ax invalid ( $x=16..25$ )	3	-	ns
$t_d(\text{CLKL-NOEL})$	FSMC_CLK low to FSMC_NOE low	-	1	ns
$t_d(\text{CLKL-NOEH})$	FSMC_CLK low to FSMC_NOE high	1.5	-	ns
$t_{su}(\text{DV-CLKH})$	FSMC_D[15:0] valid data before FSMC_CLK high	8	-	ns
$t_h(\text{CLKH-DV})$	FSMC_D[15:0] valid data after FSMC_CLK high	3.5	-	ns

- $C_L = 30 \text{ pF}$ .
- Based on characterization, not tested in production.

Figure 61. Synchronous non-multiplexed PSRAM write timings

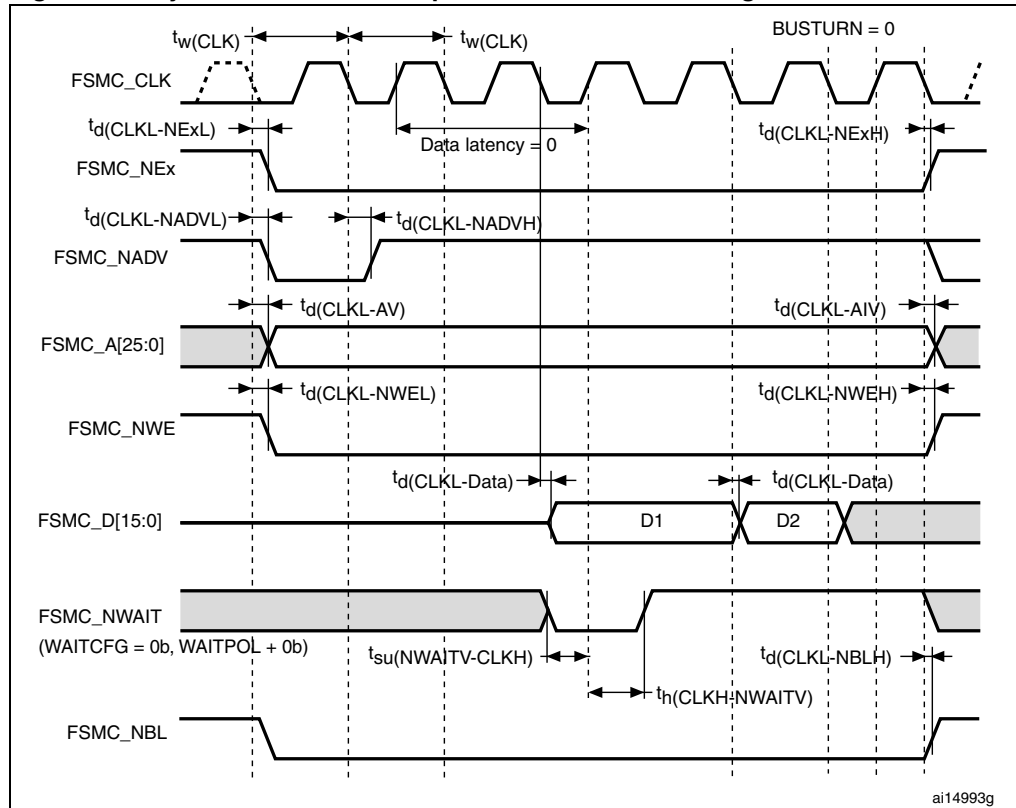


Table 75. Synchronous non-multiplexed PSRAM write timings<sup>(1)(2)</sup>

Symbol	Parameter	Min	Max	Unit
$t_w(\text{CLK})$	FSMC_CLK period	$2T_{\text{HCLK}} - 1$	-	ns
$t_d(\text{CLKL-NExL})$	FSMC_CLK low to FSMC_NEx low (x=0..2)	-	1	ns
$t_d(\text{CLKL-NExH})$	FSMC_CLK low to FSMC_NEx high (x= 0...2)	1	-	ns
$t_d(\text{CLKL-NADVl})$	FSMC_CLK low to FSMC_NADV low	-	5	ns
$t_d(\text{CLKL-NADVH})$	FSMC_CLK low to FSMC_NADV high	6	-	ns
$t_d(\text{CLKL-AV})$	FSMC_CLK low to FSMC_Ax valid (x=16...25)	-	0	ns
$t_d(\text{CLKL-AIV})$	FSMC_CLK low to FSMC_Ax invalid (x=16...25)	8	-	ns
$t_d(\text{CLKL-NWEL})$	FSMC_CLK low to FSMC_NWE low	-	1	ns
$t_d(\text{CLKL-NWEH})$	FSMC_CLK low to FSMC_NWE high	1	-	ns
$t_d(\text{CLKL-Data})$	FSMC_D[15:0] valid data after FSMC_CLK low	-	2	ns
$t_d(\text{CLKL-NBLH})$	FSMC_CLK low to FSMC_NBL high	2	-	ns

1.  $C_L = 30 \text{ pF}$ .
2. Based on characterization, not tested in production.

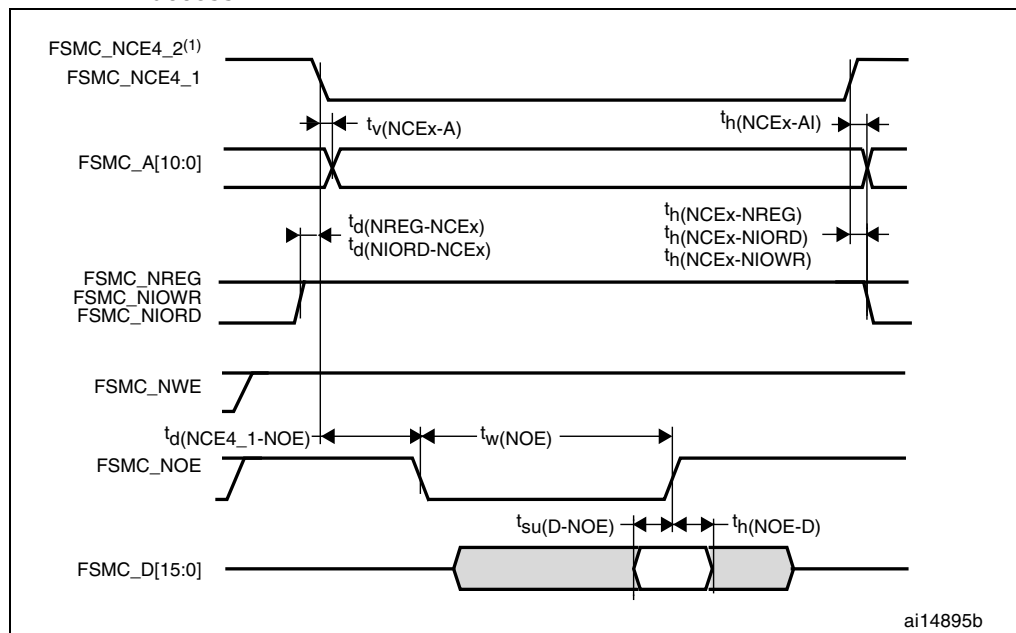
**PC Card/CompactFlash controller waveforms and timings**

Figure 62 through Figure 67 represent synchronous waveforms together with Table 76 and Table 77 provides the corresponding timings. The results shown in this table are obtained with the following FSMC configuration:

- COM.FSMC\_SetupTime = 0x04;
- COM.FSMC\_WaitSetupTime = 0x07;
- COM.FSMC\_HoldSetupTime = 0x04;
- COM.FSMC\_HiZSetupTime = 0x00;
- ATT.FSMC\_SetupTime = 0x04;
- ATT.FSMC\_WaitSetupTime = 0x07;
- ATT.FSMC\_HoldSetupTime = 0x04;
- ATT.FSMC\_HiZSetupTime = 0x00;
- IO.FSMC\_SetupTime = 0x04;
- IO.FSMC\_WaitSetupTime = 0x07;
- IO.FSMC\_HoldSetupTime = 0x04;
- IO.FSMC\_HiZSetupTime = 0x00;
- TCLRSetupTime = 0;
- TARSetupTime = 0;

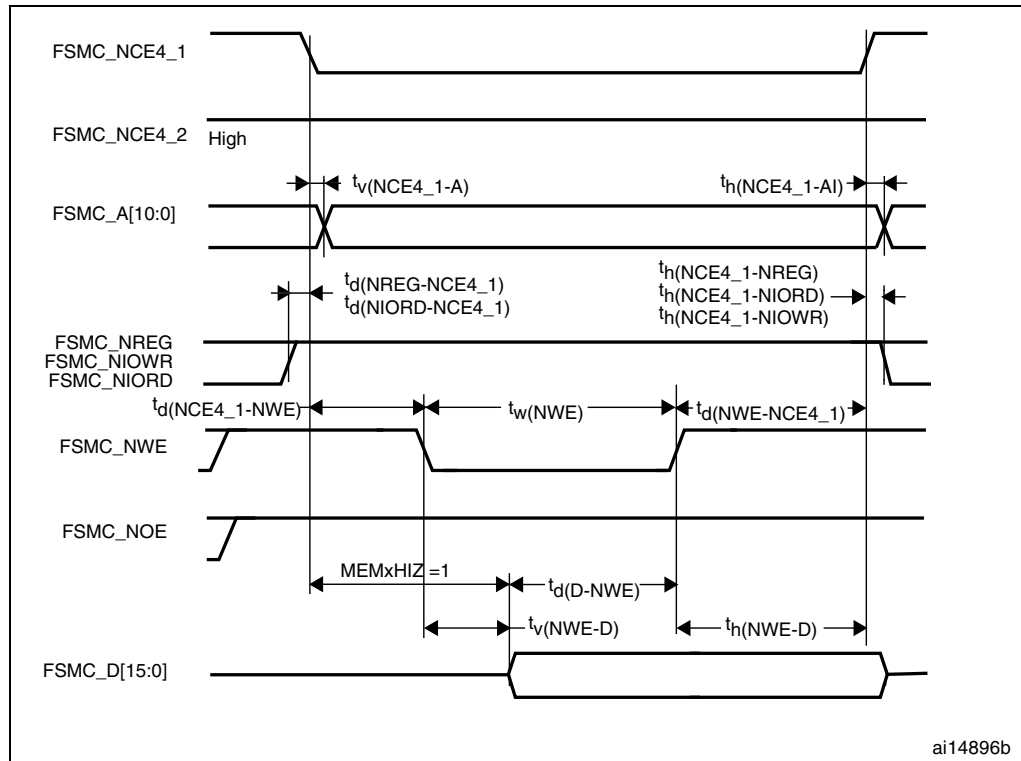
In all timing tables, the  $T_{HCLK}$  is the HCLK clock period.

**Figure 62. PC Card/CompactFlash controller waveforms for common memory read access**

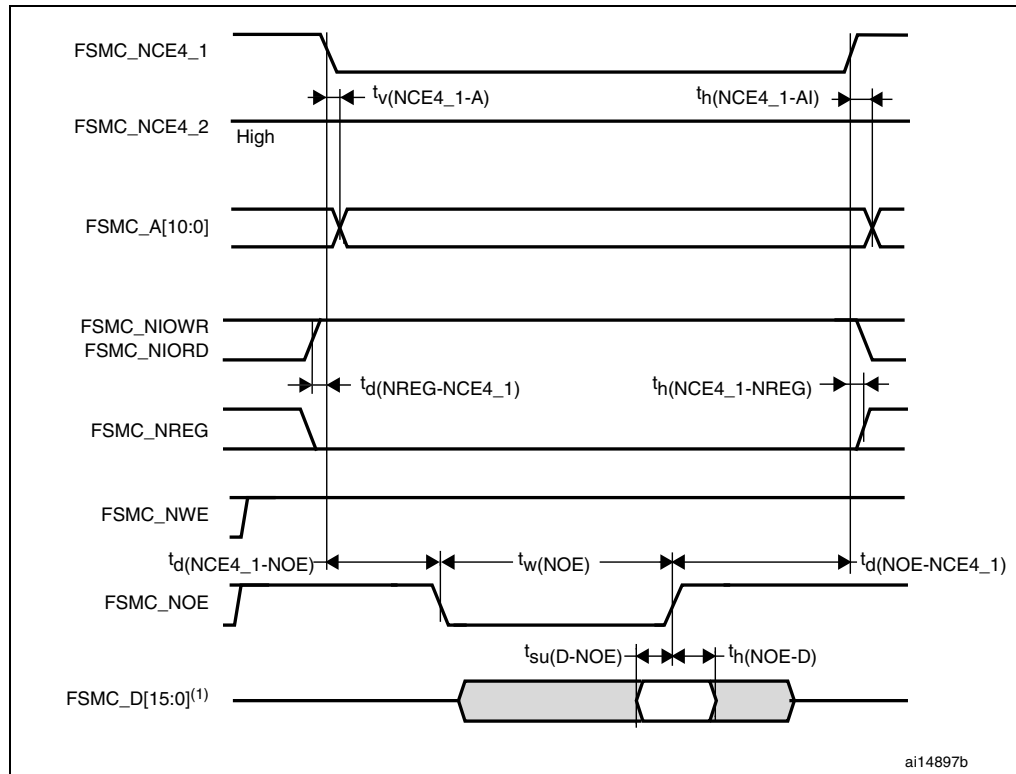


1. FSMC\_NCE4\_2 remains high (inactive during 8-bit access).

**Figure 63. PC Card/CompactFlash controller waveforms for common memory write access**

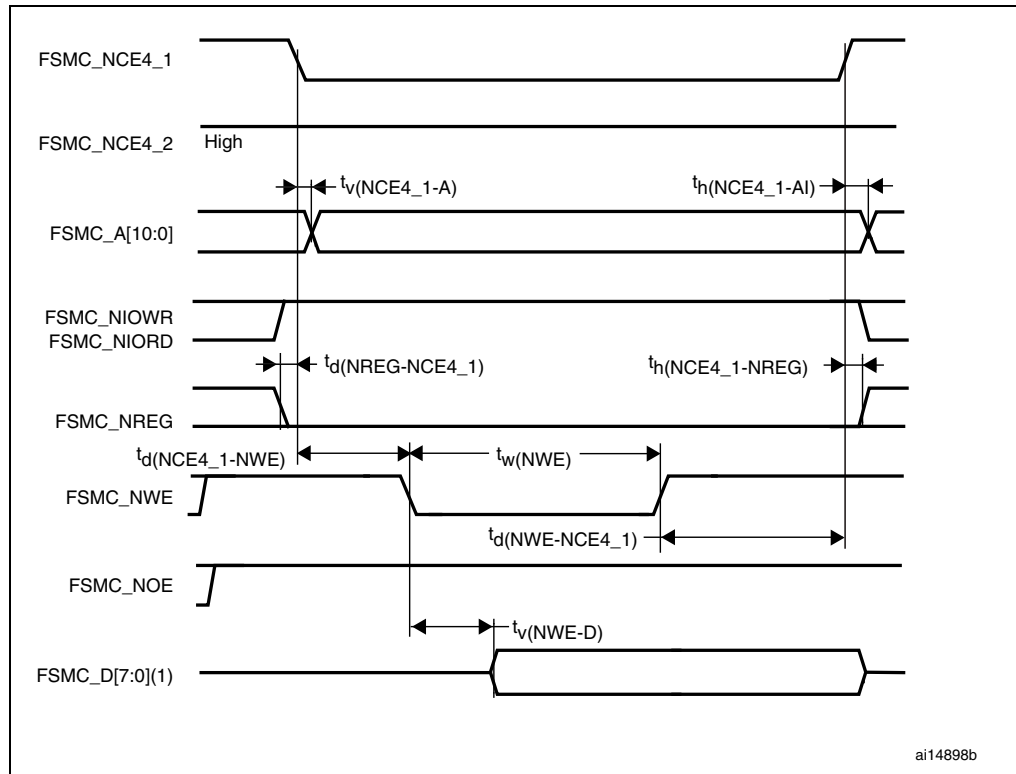


**Figure 64. PC Card/CompactFlash controller waveforms for attribute memory read access**



1. Only data bits 0...7 are read (bits 8...15 are disregarded).

**Figure 65. PC Card/CompactFlash controller waveforms for attribute memory write access**



1. Only data bits 0...7 are driven (bits 8...15 remains Hi-Z).

**Figure 66. PC Card/CompactFlash controller waveforms for I/O space read access**

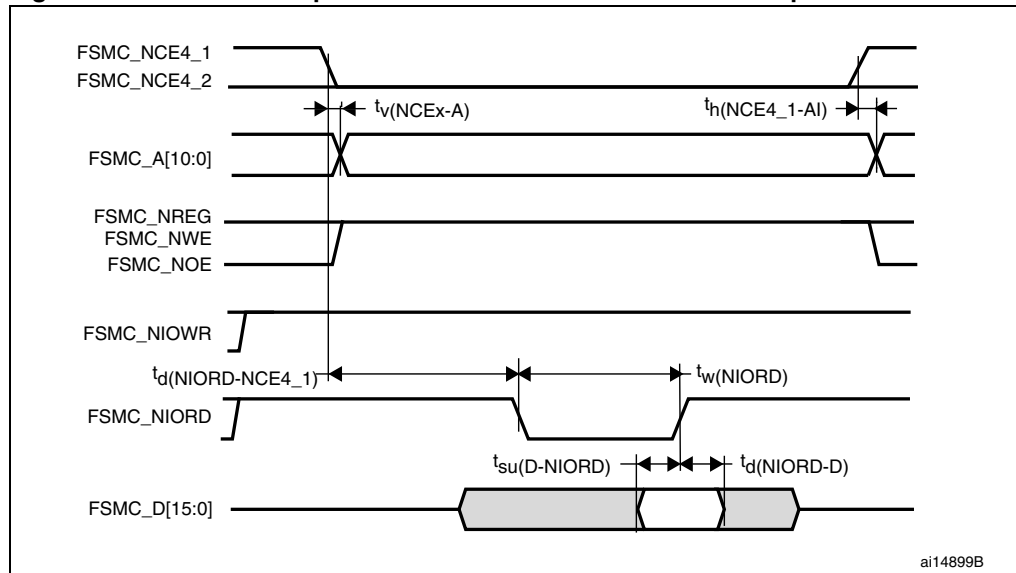


Figure 67. PC Card/CompactFlash controller waveforms for I/O space write access

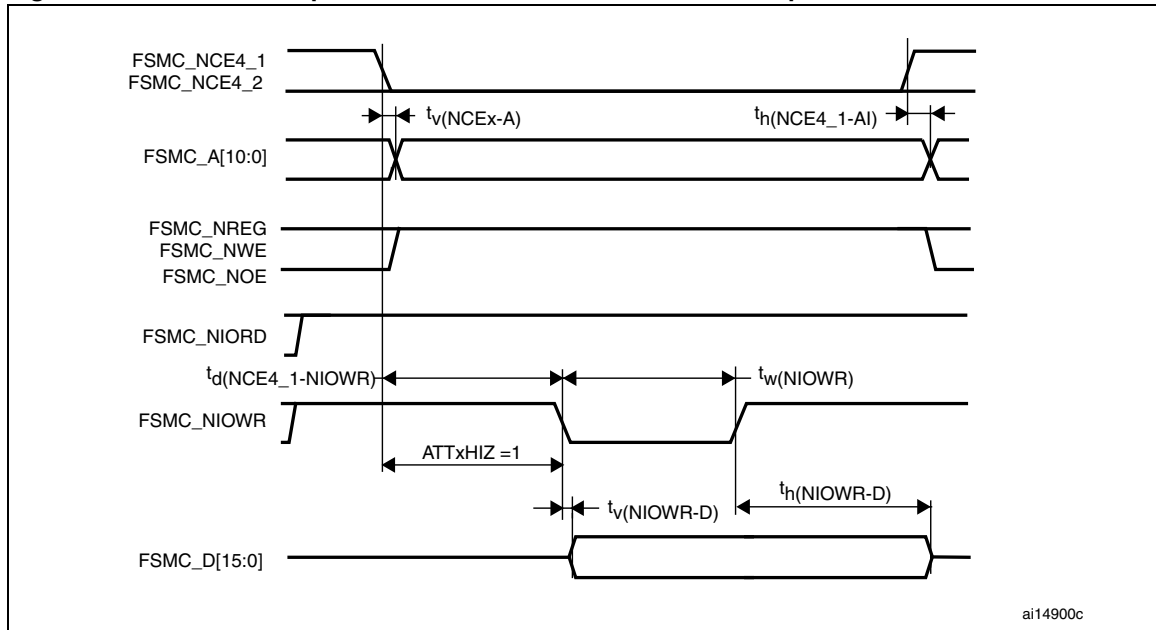


Table 76. Switching characteristics for PC Card/CF read and write cycles in attribute/common space<sup>(1)(2)</sup>

Symbol	Parameter	Min	Max	Unit
$t_v(NCEx-A)$	FSMC_Ncex low to FSMC_Ay valid	-	0	ns
$t_h(NCEx-AI)$	FSMC_NCEx high to FSMC_Ax invalid	4	-	ns
$t_d(NREG-NCEx)$	FSMC_NCEx low to FSMC_NREG valid	-	3.5	ns
$t_h(NCEx-NREG)$	FSMC_NCEx high to FSMC_NREG invalid	$T_{HCLK} + 4$	-	ns
$t_d(NCEx-NWE)$	FSMC_NCEx low to FSMC_NWE low	-	$5T_{HCLK} + 1$	ns
$t_d(NCEx-NOE)$	FSMC_NCEx low to FSMC_NOE low	-	$5T_{HCLK}$	ns
$t_w(NOE)$	FSMC_NOE low width	$8T_{HCLK} - 0.5$	$8T_{HCLK} + 1$	ns
$t_d(NOE-NCEx)$	FSMC_NOE high to FSMC_NCEx high	$5T_{HCLK} + 2.5$	-	ns
$t_{su}(D-NOE)$	FSMC_D[15:0] valid data before FSMC_NOE high	4	-	ns
$t_h(NOE-D)$	FSMC_NOE high to FSMC_D[15:0] invalid	2	-	ns
$t_w(NWE)$	FSMC_NWE low width	$8T_{HCLK} - 1$	$8T_{HCLK} + 4$	ns
$t_d(NWE-NCEx)$	FSMC_NWE high to FSMC_NCEx high	$5T_{HCLK} + 1.5$	-	ns
$t_d(NCEx-NWE)$	FSMC_NCEx low to FSMC_NWE low	-	$5T_{HCLK} + 1$	ns
$t_v(NWE-D)$	FSMC_NWE low to FSMC_D[15:0] valid	-	0	ns
$t_h(NWE-D)$	FSMC_NWE high to FSMC_D[15:0] invalid	$8 T_{HCLK}$	-	ns
$t_d(D-NWE)$	FSMC_D[15:0] valid before FSMC_NWE high	$13T_{HCLK}$	-	ns

1.  $C_L = 30$  pF.

2. Based on characterization, not tested in production.

**Table 77. Switching characteristics for PC Card/CF read and write cycles in I/O space<sup>(1)(2)</sup>**

Symbol	Parameter	Min	Max	Unit
$t_w(\text{NIOWR})$	FSMC_NIOWR low width	$8T_{\text{HCLK}} - 0.5$	-	ns
$t_v(\text{NIOWR-D})$	FSMC_NIOWR low to FSMC_D[15:0] valid	-	$5T_{\text{HCLK}} - 1$	ns
$t_h(\text{NIOWR-D})$	FSMC_NIOWR high to FSMC_D[15:0] invalid	$8T_{\text{HCLK}} - 3$	-	ns
$t_d(\text{NCE4}_1\text{-NIOWR})$	FSMC_NCE4_1 low to FSMC_NIOWR valid	-	$5T_{\text{HCLK}} + 1.5$	ns
$t_h(\text{NCEx-NIOWR})$	FSMC_NCEx high to FSMC_NIOWR invalid	$5T_{\text{HCLK}}$	-	ns
$t_d(\text{NIORD-NCEx})$	FSMC_NCEx low to FSMC_NIORD valid	-	$5T_{\text{HCLK}} + 1$	ns
$t_h(\text{NCEx-NIORD})$	FSMC_NCEx high to FSMC_NIORD) valid	$5T_{\text{HCLK}} - 0.5$	-	ns
$t_w(\text{NIORD})$	FSMC_NIORD low width	$8T_{\text{HCLK}} + 1$	-	ns
$t_{su}(\text{D-NIORD})$	FSMC_D[15:0] valid before FSMC_NIORD high	9.5		ns
$t_d(\text{NIORD-D})$	FSMC_D[15:0] valid after FSMC_NIORD high	0		ns

1.  $C_L = 30$  pF.

2. Based on characterization, not tested in production.

### NAND controller waveforms and timings

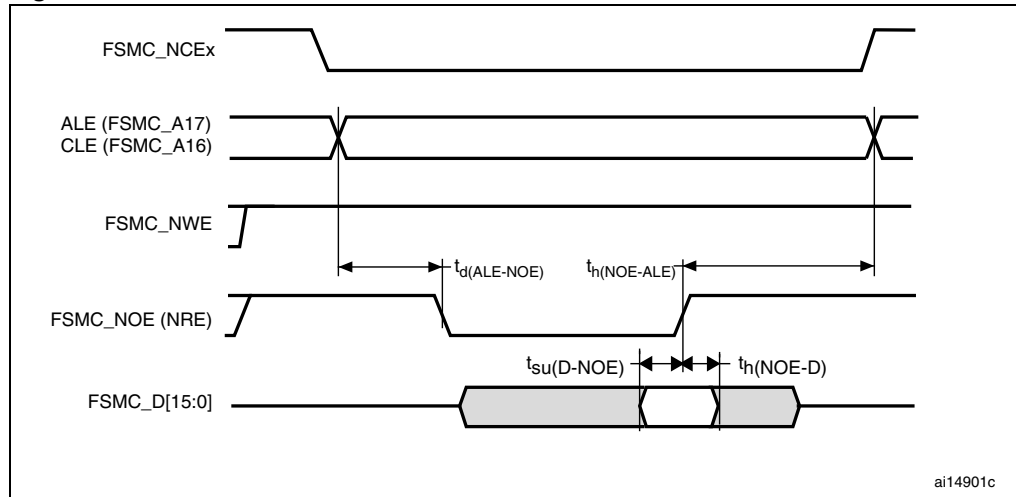
[Figure 68](#) through [Figure 71](#) represent synchronous waveforms, together with [Table 78](#) and [Table 79](#) provides the corresponding timings. The results shown in this table are obtained with the following FSMC configuration:

- COM.FSMC\_SetupTime = 0x01;
- COM.FSMC\_WaitSetupTime = 0x03;
- COM.FSMC\_HoldSetupTime = 0x02;
- COM.FSMC\_HiZSetupTime = 0x01;
- ATT.FSMC\_SetupTime = 0x01;
- ATT.FSMC\_WaitSetupTime = 0x03;
- ATT.FSMC\_HoldSetupTime = 0x02;
- ATT.FSMC\_HiZSetupTime = 0x01;
- Bank = FSMC\_Bank\_NAND;
- MemoryDataWidth = FSMC\_MemoryDataWidth\_16b;
- ECC = FSMC\_ECC\_Enable;
- ECCPageSize = FSMC\_ECCPageSize\_512Bytes;
- TCLRSetupTime = 0;
- TARSetupTime = 0;

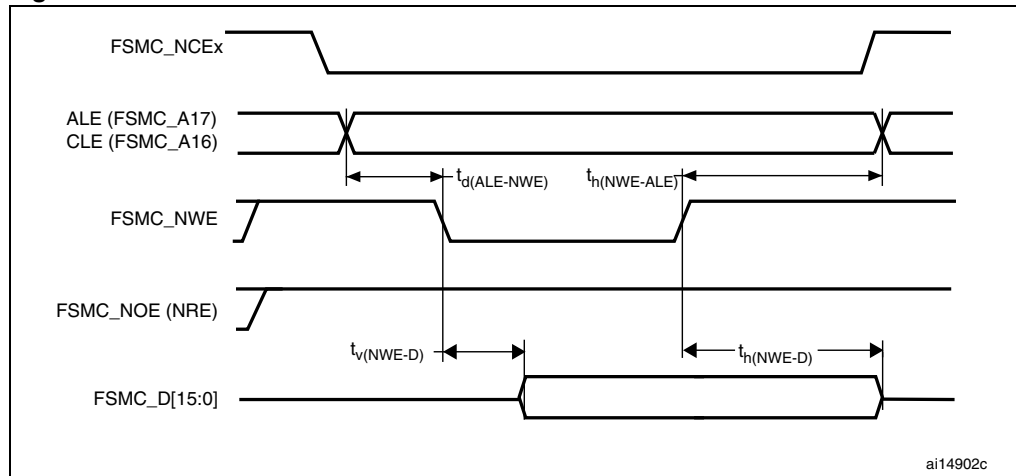
In all timing tables, the  $T_{\text{HCLK}}$  is the HCLK clock period.



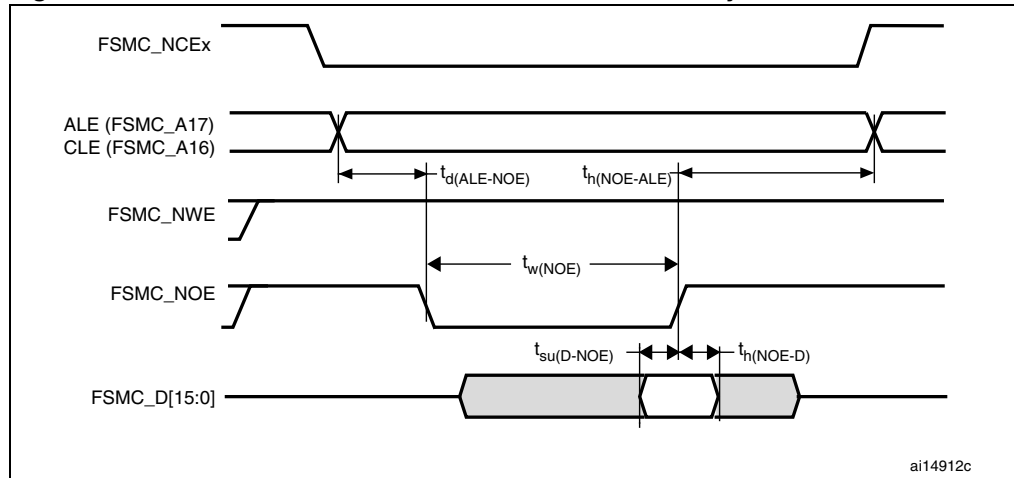
**Figure 68. NAND controller waveforms for read access**



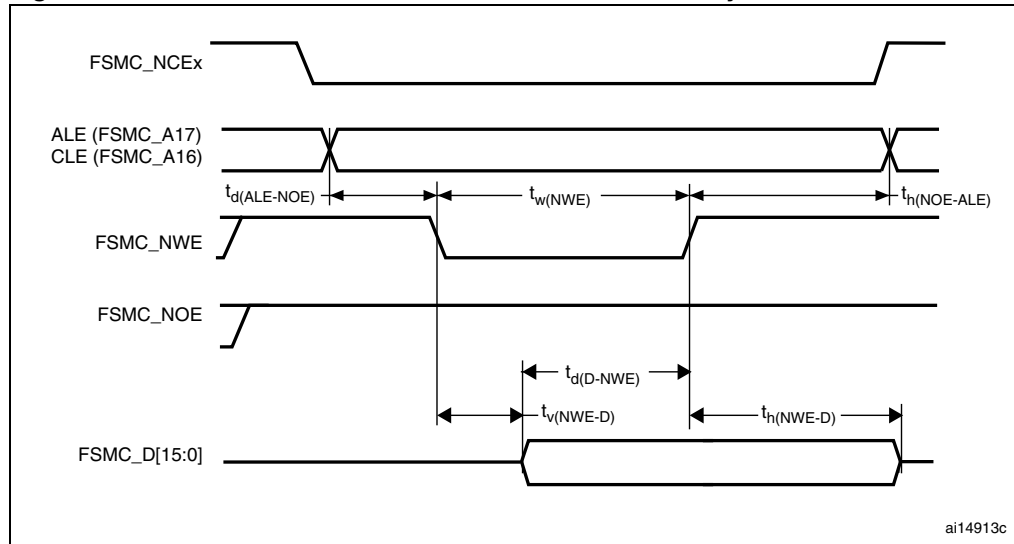
**Figure 69. NAND controller waveforms for write access**



**Figure 70. NAND controller waveforms for common memory read access**



**Figure 71. NAND controller waveforms for common memory write access**



**Table 78. Switching characteristics for NAND Flash read cycles<sup>(1)(2)</sup>**

Symbol	Parameter	Min	Max	Unit
$t_{w(NOE)}$	FSMC_NOE low width	$4T_{HCLK} - 1$	$4T_{HCLK} + 2$	ns
$t_{su(D-NOE)}$	FSMC_D[15:0] valid data before FSMC_NOE high	9	-	ns
$t_{h(NOE-D)}$	FSMC_D[15:0] valid data after FSMC_NOE high	3	-	ns
$t_{d(ALE-NOE)}$	FSMC_ALE valid before FSMC_NOE low	-	$3T_{HCLK}$	ns
$t_{h(NOE-ALE)}$	FSMC_NWE high to FSMC_ALE invalid	$3T_{HCLK} + 2$	-	ns

1.  $C_L = 30$  pF.
2. Based on characterization, not tested in production.

**Table 79. Switching characteristics for NAND Flash write cycles<sup>(1)(2)</sup>**

Symbol	Parameter	Min	Max	Unit
$t_w(\text{NWE})$	FSMC_NWE low width	$4T_{\text{HCLK}} - 1$	$4T_{\text{HCLK}} + 3$	ns
$t_v(\text{NWE-D})$	FSMC_NWE low to FSMC_D[15-0] valid	-	0	ns
$t_h(\text{NWE-D})$	FSMC_NWE high to FSMC_D[15-0] invalid	$3T_{\text{HCLK}}$	-	ns
$t_d(\text{D-NWE})$	FSMC_D[15-0] valid before FSMC_NWE high	$5T_{\text{HCLK}}$	-	ns
$t_d(\text{ALE-NWE})$	FSMC_ALE valid before FSMC_NWE low	-	$3T_{\text{HCLK}} + 2$	ns
$t_h(\text{NWE-ALE})$	FSMC_NWE high to FSMC_ALE invalid	$3T_{\text{HCLK}} - 2$	-	ns

1.  $C_L = 30 \text{ pF}$ .
2. Based on characterization, not tested in production.

### 5.3.26 Camera interface (DCMI) timing specifications

**Table 80. DCMI characteristics**

Symbol	Parameter	Conditions	Min	Max	Unit
	Frequency ratio $\text{DCMI\_PIXCLK}/f_{\text{HCLK}}$	DCMI_PIXCLK= 48 MHz		0.4	

### 5.3.27 SD/SDIO MMC card host interface (SDIO) characteristics

Unless otherwise specified, the parameters given in [Table 81](#) are derived from tests performed under ambient temperature,  $f_{\text{PCLKx}}$  frequency and  $V_{\text{DD}}$  supply voltage conditions summarized in [Table 10](#).

Refer to [Section 5.3.16: I/O port characteristics](#) for more details on the input/output alternate function characteristics (D[7:0], CMD, CK).

**Figure 72. SDIO high-speed mode**

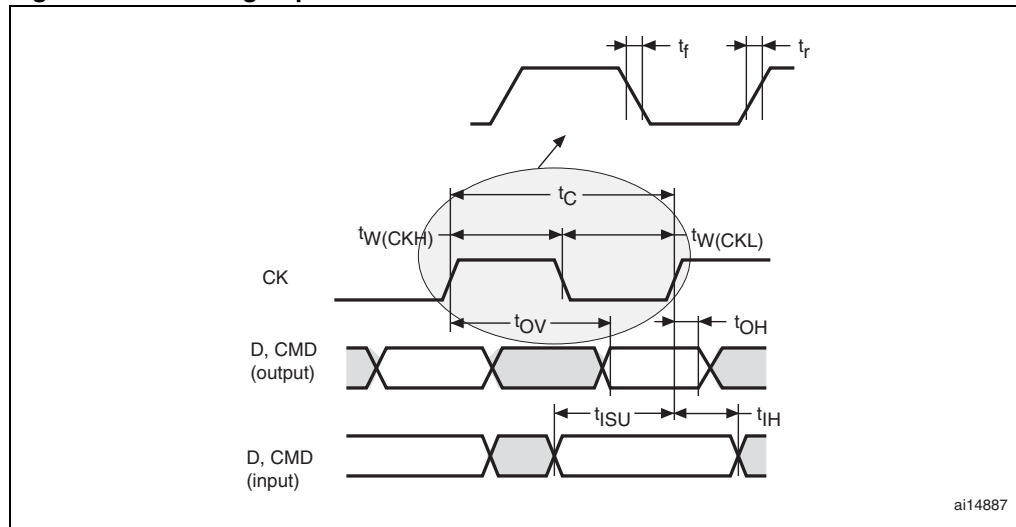


Figure 73. SD default mode

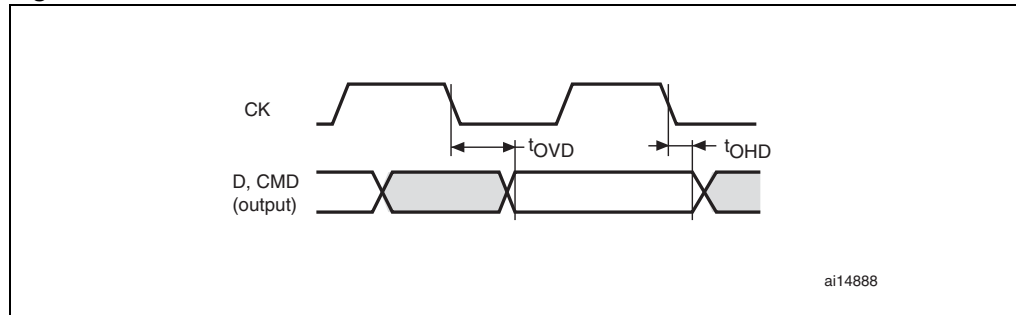


Table 81. SD / MMC characteristics

Symbol	Parameter	Conditions	Min	Max	Unit
$f_{PP}$	Clock frequency in data transfer mode	$C_L \leq 30 \text{ pF}$	0	48	MHz
-	SDIO_CK/ $f_{PCLK2}$ frequency ratio	-	-	8/3	-
$t_{W(CKL)}$	Clock low time, $f_{PP} = 16 \text{ MHz}$	$C_L \leq 30 \text{ pF}$	32		ns
$t_{W(CKH)}$	Clock high time, $f_{PP} = 16 \text{ MHz}$	$C_L \leq 30 \text{ pF}$	31		
$t_r$	Clock rise time	$C_L \leq 30 \text{ pF}$		3.5	
$t_f$	Clock fall time	$C_L \leq 30 \text{ pF}$		5	
<b>CMD, D inputs (referenced to CK)</b>					
$t_{SU}$	Input setup time	$C_L \leq 30 \text{ pF}$	2		ns
$t_{IH}$	Input hold time	$C_L \leq 30 \text{ pF}$	0		
<b>CMD, D outputs (referenced to CK) in MMC and SD HS mode</b>					
$t_{OV}$	Output valid time	$C_L \leq 30 \text{ pF}$		6	ns
$t_{OH}$	Output hold time	$C_L \leq 30 \text{ pF}$	0.3		
<b>CMD, D outputs (referenced to CK) in SD default mode<sup>(1)</sup></b>					
$t_{OVD}$	Output valid default time	$C_L \leq 30 \text{ pF}$		7	ns
$t_{OHD}$	Output hold default time	$C_L \leq 30 \text{ pF}$	0.5		

1. Refer to SDIO\_CLKCR, the SDI clock control register to control the CK output.

### 5.3.28 RTC characteristics

Table 82. RTC characteristics

Symbol	Parameter	Conditions	Min	Max	Unit
-	$f_{PCLK1}$ /RTCCLK frequency ratio	Any read/write operation from/to an RTC register	4	-	-

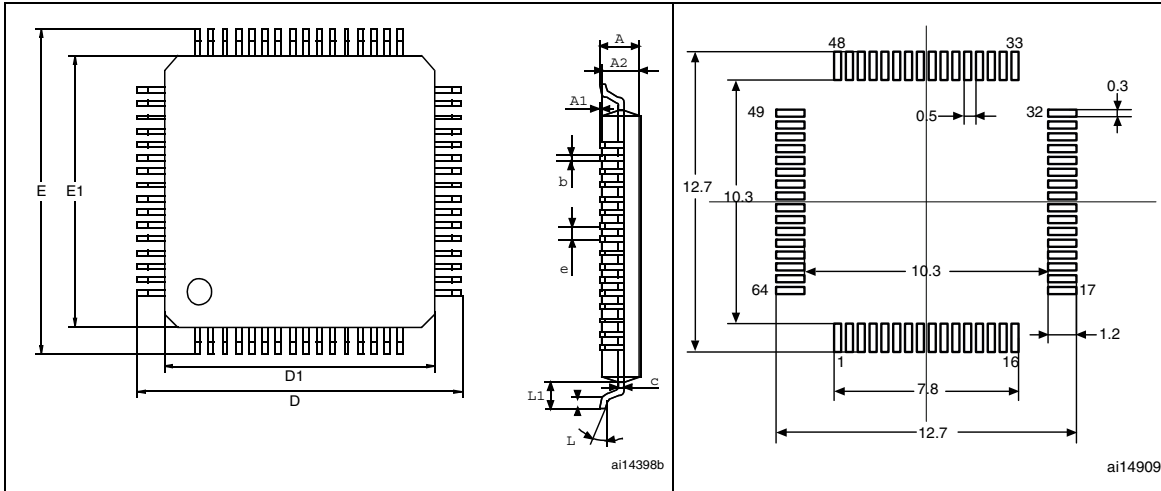
## 6 Package characteristics

### 6.1 Package mechanical data

In order to meet environmental requirements, ST offers these devices in different grades of ECOPACK<sup>®</sup> packages, depending on their level of environmental compliance. ECOPACK<sup>®</sup> specifications, grade definitions and product status are available at: [www.st.com](http://www.st.com). ECOPACK<sup>®</sup> is an ST trademark.

Figure 74. LQFP64 – 10 x 10 mm 64 pin low-profile quad flat package outline<sup>(1)</sup>

Figure 75. Recommended footprint<sup>(1)(2)</sup>



1. Drawing is not to scale.
2. Dimensions are in millimeters.

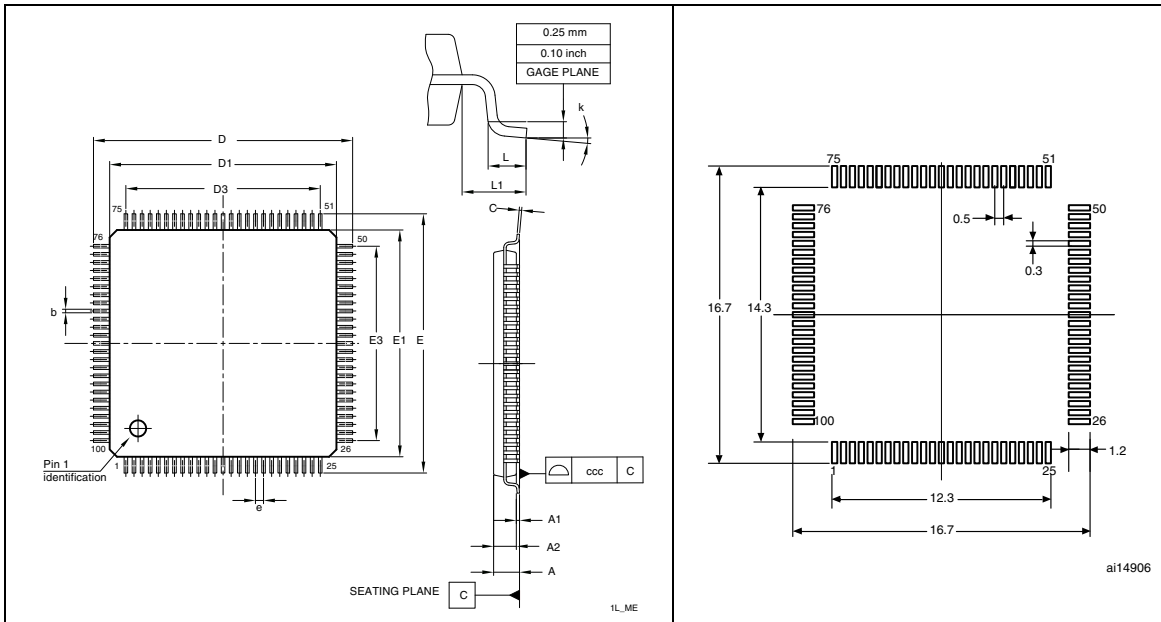
Table 83. LQFP64 – 10 x 10 mm 64 pin low-profile quad flat package mechanical data

Symbol	millimeters			inches <sup>(1)</sup>		
	Min	Typ	Max	Min	Typ	Max
A			1.600			0.0630
A1	0.050		0.150	0.0020		0.0059
A2	1.350	1.400	1.450	0.0531	0.0551	0.0571
b	0.170	0.220	0.270	0.0067	0.0087	0.0106
c	0.090		0.200	0.0035		0.0079
D		12.000			0.4724	
D1		10.000			0.3937	
E		12.000			0.4724	
E1		10.000			0.3937	
e		0.500			0.0197	
θ	0°	3.5°	7°	0°	3.5°	7°
L	0.450	0.600	0.750	0.0177	0.0236	0.0295
L1		1.000			0.0394	
N	Number of pins					
	64					

1. Values in inches are converted from mm and rounded to 4 decimal digits.

Figure 76. LQFP100, 14 x 14 mm 100-pin low-profile quad flat package outline<sup>(1)</sup>

Figure 77. Recommended footprint<sup>(1)(2)</sup>



1. Drawing is not to scale.
2. Dimensions are in millimeters.

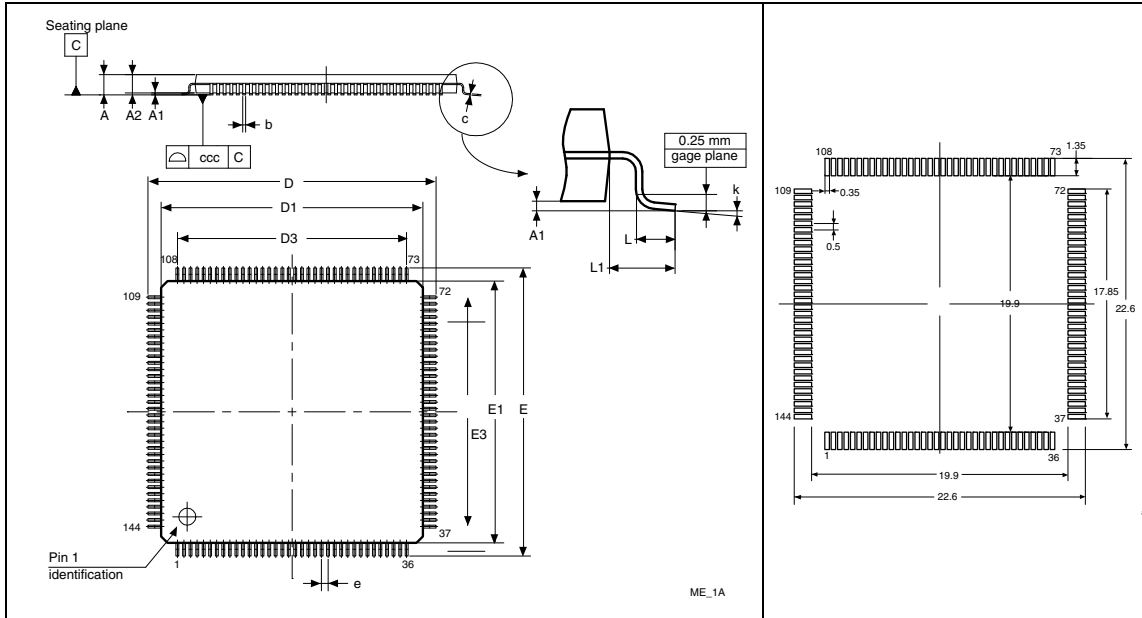
Table 84. LQPF100 – 14 x 14 mm 100-pin low-profile quad flat package mechanical data

Symbol	millimeters			inches <sup>(1)</sup>		
	Min	Typ	Max	Min	Typ	Max
A			1.600			0.0630
A1	0.050		0.150	0.0020		0.0059
A2	1.350	1.400	1.450	0.0531	0.0551	0.0571
b	0.170	0.220	0.270	0.0067	0.0087	0.0106
c	0.090		0.200	0.0035		0.0079
D	15.800	16.000	16.200	0.6220	0.6299	0.6378
D1	13.800	14.000	14.200	0.5433	0.5512	0.5591
D3		12.000			0.4724	
E	15.80v	16.000	16.200	0.6220	0.6299	0.6378
E1	13.800	14.000	14.200	0.5433	0.5512	0.5591
E3		12.000			0.4724	
e		0.500			0.0197	
L	0.450	0.600	0.750	0.0177	0.0236	0.0295
L1		1.000			0.0394	
k	0°	3.5°	7°	0°	3.5°	7°
ccc		0.080			0.0031	

1. Values in inches are converted from mm and rounded to 4 decimal digits.

Figure 78. LQFP144, 20 x 20 mm, 144-pin low-profile quad flat package outline<sup>(1)</sup>

Figure 79. Recommended footprint<sup>(1)(2)</sup>



1. Drawing is not to scale.
2. Dimensions are in millimeters.

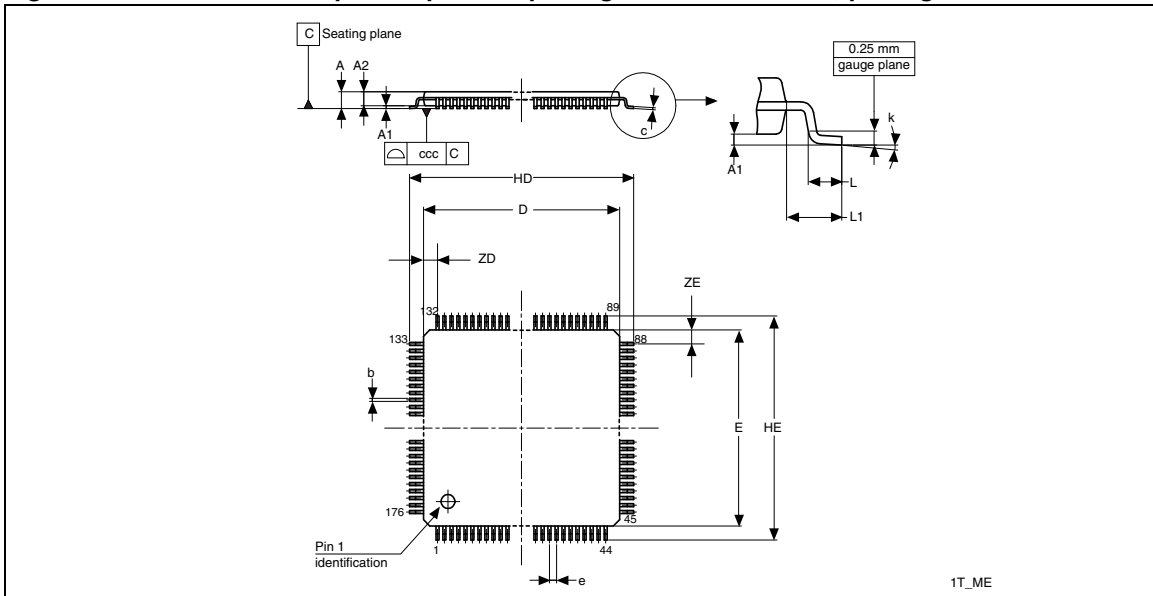
Table 85. LQFP144 20 x 20 mm, 144-pin low-profile quad flat package mechanical data

Symbol	millimeters			inches <sup>(1)</sup>		
	Min	Typ	Max	Min	Typ	Max
A			1.600			0.0630
A1	0.050		0.150	0.0020		0.0059
A2	1.350	1.400	1.450	0.0531	0.0551	0.0571
b	0.170	0.220	0.270	0.0067	0.0087	0.0106
c	0.090		0.200	0.0035		0.0079
D	21.800	22.000	22.200	0.8583	0.8661	0.874
D1	19.800	20.000	20.200	0.7795	0.7874	0.7953
D3		17.500			0.689	
E	21.800	22.000	22.200	0.8583	0.8661	0.8740
E1	19.800	20.000	20.200	0.7795	0.7874	0.7953
E3		17.500			0.6890	
e		0.500			0.0197	
L	0.450	0.600	0.750	0.0177	0.0236	0.0295
L1		1.000			0.0394	
k	0°	3.5°	7°	0°	3.5°	7°
ccc		0.080			0.0031	

1. Values in inches are converted from mm and rounded to 4 decimal digits.



Figure 80. LQFP176 - Low profile quad flat package 24 × 24 × 1.4 mm, package outline



1. Drawing is not to scale.

Table 86. LQFP176 - Low profile quad flat package 24 × 24 × 1.4 mm package mechanical data

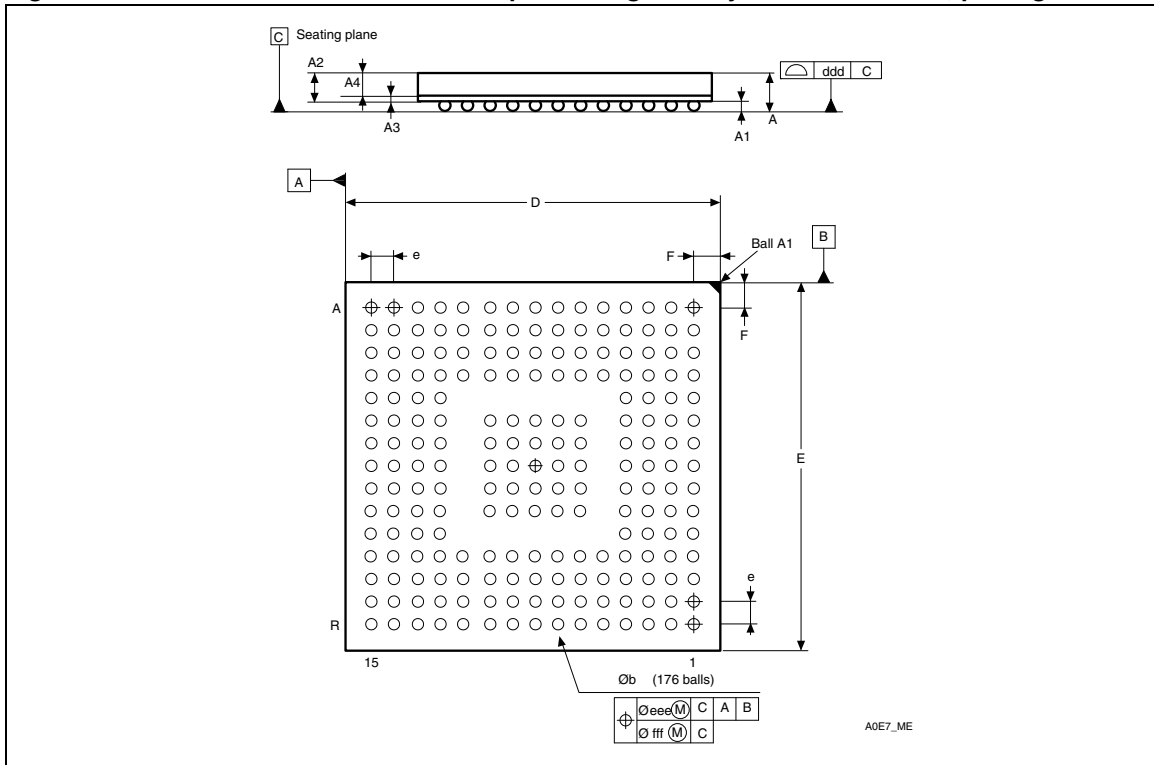
Symbol	millimeters			inches <sup>(1)</sup>		
	Min	Typ	Max	Min	Typ	Max
A			1.600			0.0630
A1	0.050		0.150	0.0020		0.0059
A2	1.350		1.450	0.0531		0.0571
b	0.170		0.270	0.0067		0.0106
c	0.090		0.200	0.0035		0.0079
D	23.900		24.100	0.9409		0.9488
E	23.900		24.100	0.9409		0.9488
e		0.500			0.0197	
HD	25.900		26.100	1.0197		1.0276
HE	25.900		26.100	1.0197		1.0276
L <sup>(2)</sup>	0.450		0.750	0.0177		0.0295
L1		1.000			0.0394	
ZD		1.250			0.0492	
ZE		1.250			0.0492	

**Table 86. LQFP176 - Low profile quad flat package 24 × 24 × 1.4 mm package mechanical data**

k	0°		7°	0°		7°
ccc	0.080			0.0031		

1. Values in inches are converted from mm and rounded to 4 decimal digits.
2. L dimension is measured at gauge plane at 0.25 mm above the seating plane.

Figure 81. UFBGA176+25 - ultra thin fine pitch ball grid array 10 × 10 × 0.6 mm, package outline



1. Drawing is not to scale.

Table 87. UFBGA176+25 - ultra thin fine pitch ball grid array 10 × 10 × 0.6 mm mechanical data

Symbol	millimeters			inches <sup>(1)</sup>		
	Min	Typ	Max	Min	Typ	Max
A	0.460	0.530	0.600	0.0181	0.0209	0.0236
A1	0.050	0.080	0.110	0.002	0.0031	0.0043
A2	0.400	0.450	0.500	0.0157	0.0177	0.0197
A3	0.130			0.0051		
A4	0.270	0.320	0.370	0.0106	0.0126	0.0146
b	0.230	0.280	0.330	0.0091	0.0110	0.0130
D	9.950	10.000	10.050	0.3740	0.3937	0.3957
E	9.950	10.000	10.050	0.3740	0.3937	0.3957
e	0.600	0.650	0.700	0.0236	0.0256	0.0276
F	0.400	0.450	0.500	0.0157	0.0177	0.0197

**Table 87. UFBGA176+25 - ultra thin fine pitch ball grid array 10 × 10 × 0.6 mm mechanical data**

ddd	0.080	0.0031
eee	0.150	0.0059
fff	0.080	0.0031

1. Values in inches are converted from mm and rounded to 4 decimal digits.

## 6.2 Thermal characteristics

The maximum chip-junction temperature,  $T_J \text{ max}$ , in degrees Celsius, may be calculated using the following equation:

$$T_J \text{ max} = T_A \text{ max} + (P_D \text{ max} \times \Theta_{JA})$$

Where:

- $T_A \text{ max}$  is the maximum ambient temperature in °C,
- $\Theta_{JA}$  is the package junction-to-ambient thermal resistance, in °C/W,
- $P_D \text{ max}$  is the sum of  $P_{INT} \text{ max}$  and  $P_{I/O} \text{ max}$  ( $P_D \text{ max} = P_{INT} \text{ max} + P_{I/O} \text{ max}$ ),
- $P_{INT} \text{ max}$  is the product of  $I_{DD}$  and  $V_{DD}$ , expressed in Watts. This is the maximum chip internal power.

$P_{I/O} \text{ max}$  represents the maximum power dissipation on output pins where:

$$P_{I/O} \text{ max} = \Sigma (V_{OL} \times I_{OL}) + \Sigma ((V_{DD} - V_{OH}) \times I_{OH}),$$

taking into account the actual  $V_{OL} / I_{OL}$  and  $V_{OH} / I_{OH}$  of the I/Os at low and high level in the application.

**Table 88. Package thermal characteristics**

Symbol	Parameter	Value	Unit
$\Theta_{JA}$	Thermal resistance junction-ambient LQFP 64 - 10 × 10 mm / 0.5 mm pitch	45	°C/W
	Thermal resistance junction-ambient LQFP100 - 14 × 14 mm / 0.5 mm pitch	46	
	Thermal resistance junction-ambient LQFP144 - 20 × 20 mm / 0.5 mm pitch	40	
	Thermal resistance junction-ambient LQFP176 - 24 × 24 mm / 0.5 mm pitch	38	
	Thermal resistance junction-ambient UFBGA176 - 10 × 10 mm / 0.5 mm pitch	39	

### Reference document

JESD51-2 Integrated Circuits Thermal Test Method Environment Conditions - Natural Convection (Still Air). Available from [www.jedec.org](http://www.jedec.org).

## 7 Part numbering

Table 89. Ordering information scheme

Example:	STM32	F	215	R	E	T	6	V	xxx
<b>Device family</b> STM32 = ARM-based 32-bit microcontroller									
<b>Product type</b> F = general-purpose									
<b>Device subfamily</b> 215 = STM32F21x, connectivity, USB OTG FS/HS, cryptographic acceleration 217 = STM32F21x, connectivity, USB OTG FS/HS, camera interface, cryptographic acceleration, Ethernet									
<b>Pin count</b> R = 64 pins V = 100 pins Z = 144 pins I = 176 pins									
<b>Flash memory size</b> E = 512 Kbytes of Flash memory G = 1024 Kbytes of Flash memory									
<b>Package</b> T = LQFP H = UFBGA									
<b>Temperature range</b> 6 = Industrial temperature range, -40 to 85 °C. 7 = Industrial temperature range, -40 to 105 °C.									
<b>Software option</b> Internal code or Blank									
<b>Options</b> xxx = programmed parts TR = tape and reel									

For a list of available options (speed, package, etc.) or for further information on any aspect of this device, please contact your nearest ST sales office.

## Appendix A Application block diagrams

### A.1 Main applications versus package

Table 90 gives examples of configurations for each package.

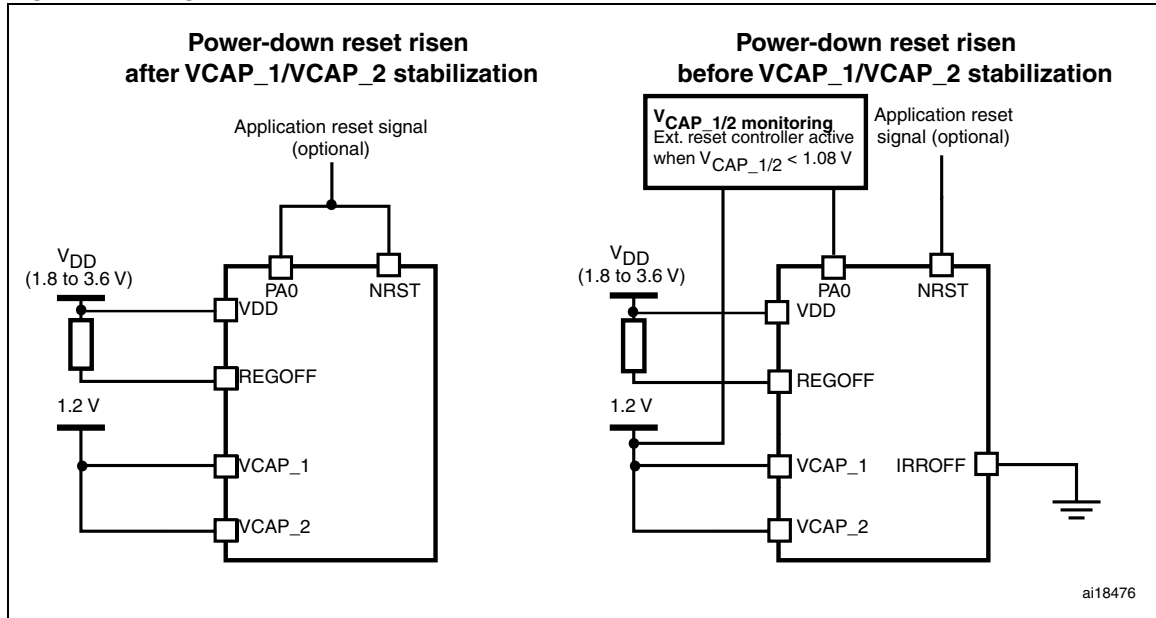
Table 90. Main applications versus package for STM32F2xxx microcontrollers<sup>(1)</sup>

		64 pins <sup>(2)</sup>			100 pins				144 pins				176 pins	
		Config 1	Config 2	Config 3	Config 1	Config 2	Config 3	Config 4	Config 1	Config 2	Config 3	Config 4	Config 1	Config 2
USB OTG FS <sup>(3)</sup>	OTG FS	-	-	-	X	X	X	-	X	-	X	-	X	-
	FS	-	-	-	X	X	X	X	X	X	X	X	X	-
USB OTG HS	HS ULPI	X	-	X	X	-	-	-	X	X	-	-	X	X
	OTG FS	X	X	X	X	-	-	-	X	X	-	-	X	X
	FS	X	X	X	X	X	X	X	X	X	X	X	X	X
Ethernet <sup>(3)</sup>	MII	-	-	-	-	-	X	X	-	-	X	X	X	X
	RMI	-	-	-	-	X	X	X	X	X	X	X	X	X
SPI/I2S2 SPI/I2S3		-	X	-	-	X	X	X	X	X	X	X	X	X
SDIO	SDIO	X	X	-				X		X		X	X	X
DCMI <sup>(3)</sup>	8-bit Data	-	-	-	SDIO or DCMI	SDIO or DCMI	SDIO or DCMI	X	SDIO or DCMI	X	SDIO or DCMI	X	X	X
	10-bit Data	-	-	-				X				X		
	12-bit Data	-	-	-				X				X		
	14-bit Data	-	-	-				-				-		
FSMC	NOR/RAM Muxed	-	-	-	X	X	X	X	X	X	X	X	X	X
	NOR/RAM	-	-	-					X	X	X	X	X	X
	NAND	-	-	-	X	X	X <sup>*22</sup>	X <sup>*19</sup>	X	X <sup>*19</sup>	X <sup>*22</sup>	X <sup>*19</sup>	X <sup>*22</sup>	X <sup>*22</sup>
	CF	-	-	-	-	-	-	-	X	X	X	X	X	X
CAN		-	X	X	-	X	X	X	-	-	X	X	-	X

1. X<sup>\*y</sup>: FSMC address limited to "y".
2. Not available on STM32F2x7xx.
3. Not available on STM32F2x5xx.

## A.2 Application example with regulator OFF

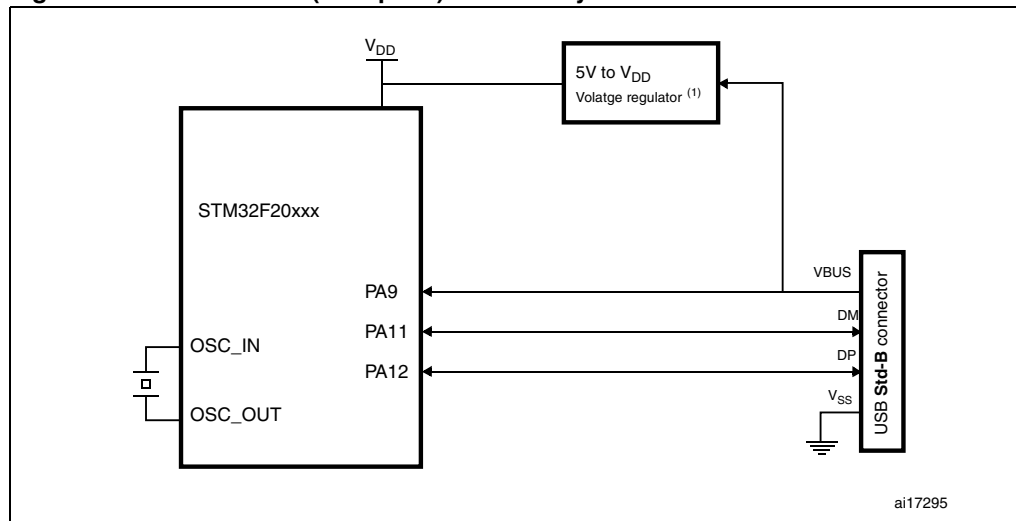
Figure 82. Regulator OFF/internal reset ON



1. This mode is available only on UFBGA176.

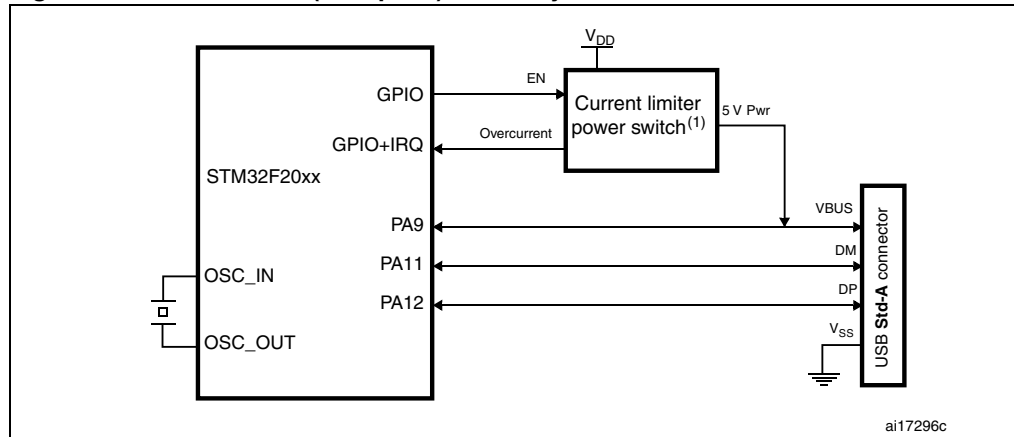
## A.3 USB OTG full speed (FS) interface solutions

Figure 83. USB OTG FS (full speed) device-only connection

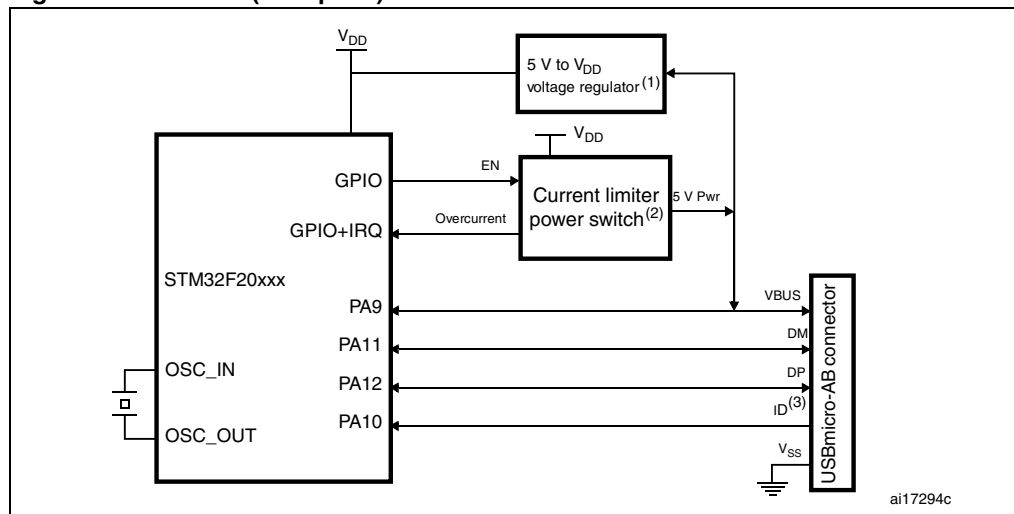


1. The same application can be developed using the OTG HS in FS mode to achieve enhanced performance thanks to the large Rx/Tx FIFO and to a dedicated DMA controller.



**Figure 84. USB OTG FS (full speed) host-only connection**

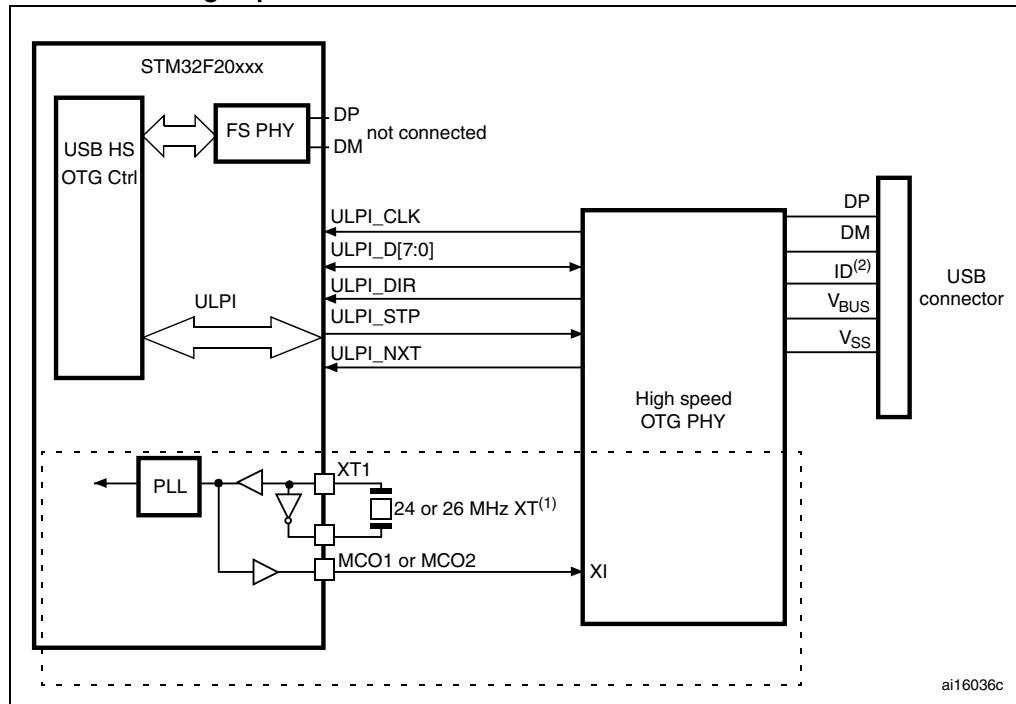
1. The current limiter is required only if the application has to support a  $V_{BUS}$  powered device. A basic power switch can be used if 5 V are available on the application board.
2. The same application can be developed using the OTG HS in FS mode to achieve enhanced performance thanks to the large Rx/Tx FIFO and to a dedicated DMA controller.

**Figure 85. OTG FS (full speed) connection dual-role with internal PHY**

1. External voltage regulator only needed when building a  $V_{BUS}$  powered device.
2. The current limiter is required only if the application has to support a  $V_{BUS}$  powered device. A basic power switch can be used if 5 V are available on the application board.
3. The ID pin is required in dual role only.
4. The same application can be developed using the OTG HS in FS mode to achieve enhanced performance thanks to the large Rx/Tx FIFO and to a dedicated DMA controller.

## A.4 USB OTG high speed (HS) interface solutions

Figure 86. OTG HS (high speed) device connection, host and dual-role in high-speed mode with external PHY



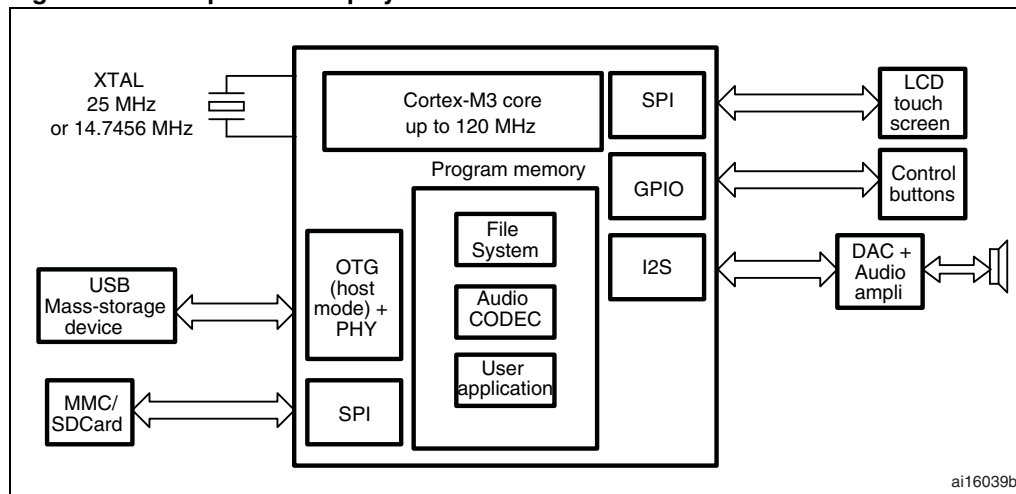
1. It is possible to use MCO1 or MCO2 to save a crystal. It is however not mandatory to clock the STM32F21x with a 24 or 26 MHz crystal when using USB HS. The above figure only shows an example of a possible connection.
2. The ID pin is required in dual role only.

## A.5 Complete audio player solutions

Two solutions are offered, illustrated in [Figure 87](#) and [Figure 88](#).

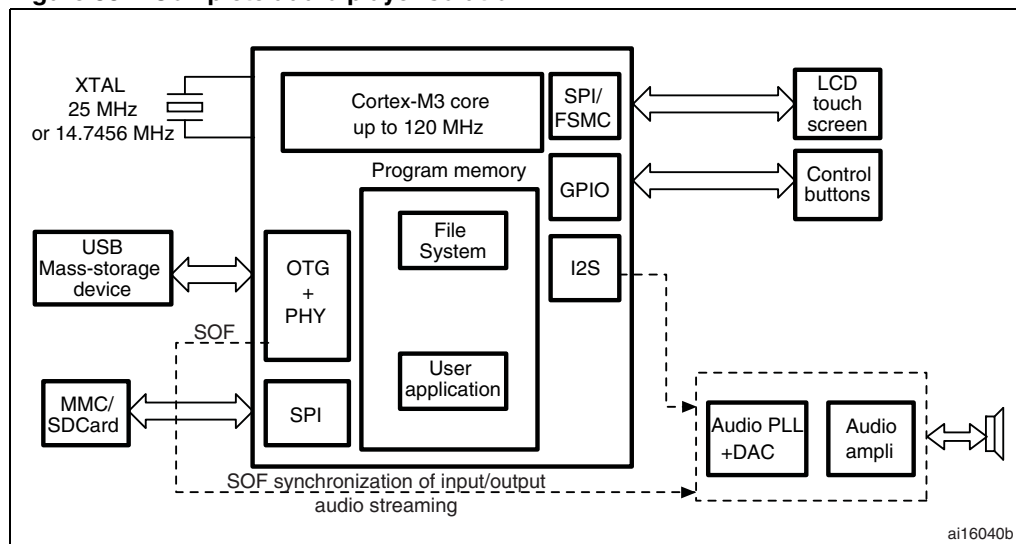
[Figure 87](#) shows storage media to audio DAC/amplifier streaming using a software Codec. This solution implements an audio crystal to provide audio class I<sup>2</sup>S accuracy on the master clock (0.5% error maximum, see the Serial peripheral interface section in the reference manual for details).

**Figure 87. Complete audio player solution 1**



[Figure 88](#) shows storage media to audio Codec/amplifier streaming with SOF synchronization of input/output audio streaming using a hardware Codec.

**Figure 88. Complete audio player solution 2**



1. SOF = start of frame.

Figure 89. Audio player solution using PLL, PLLI2S, USB and 1 crystal

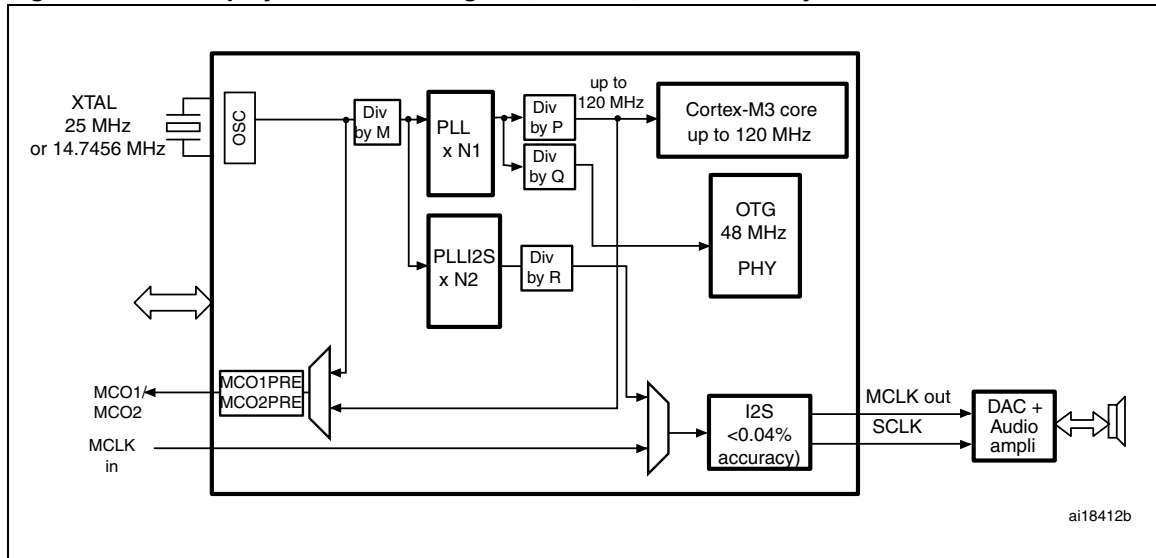
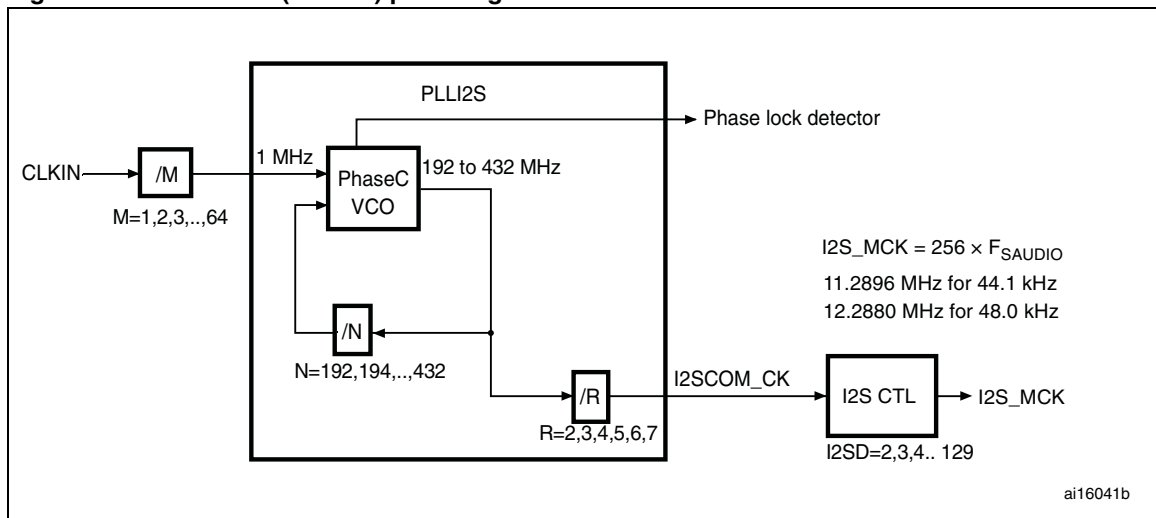
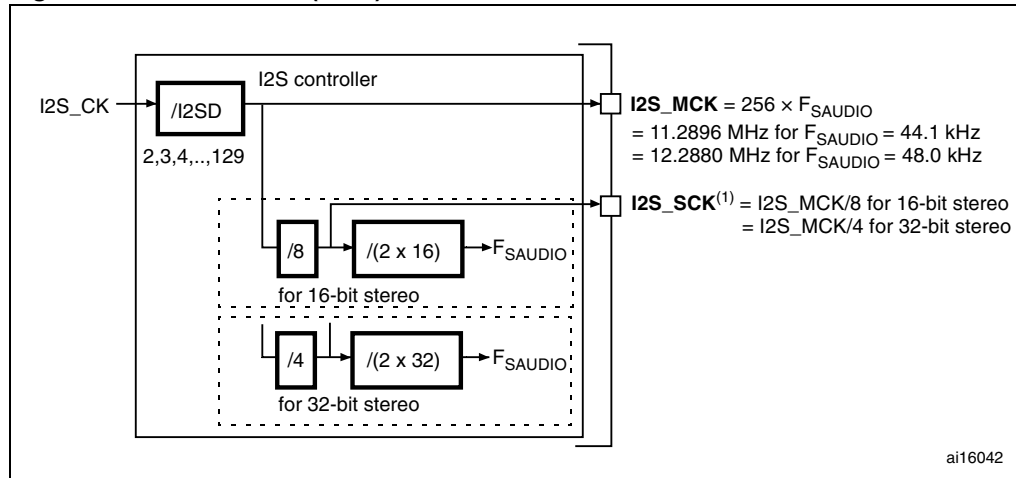


Figure 90. Audio PLL (PLLI2S) providing accurate I2S clock

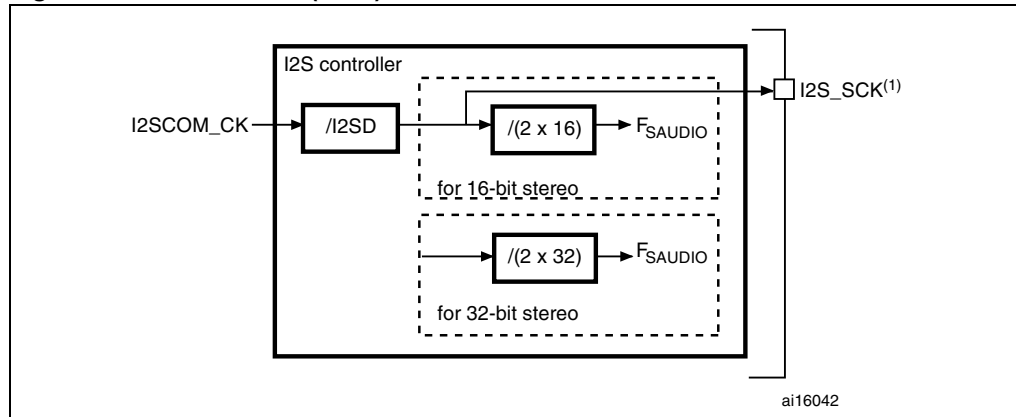


**Figure 91. Master clock (MCK) used to drive the external audio DAC**



1. I2S\_SCK is the I2S serial clock to the external audio DAC (not to be confused with I2S\_CK).

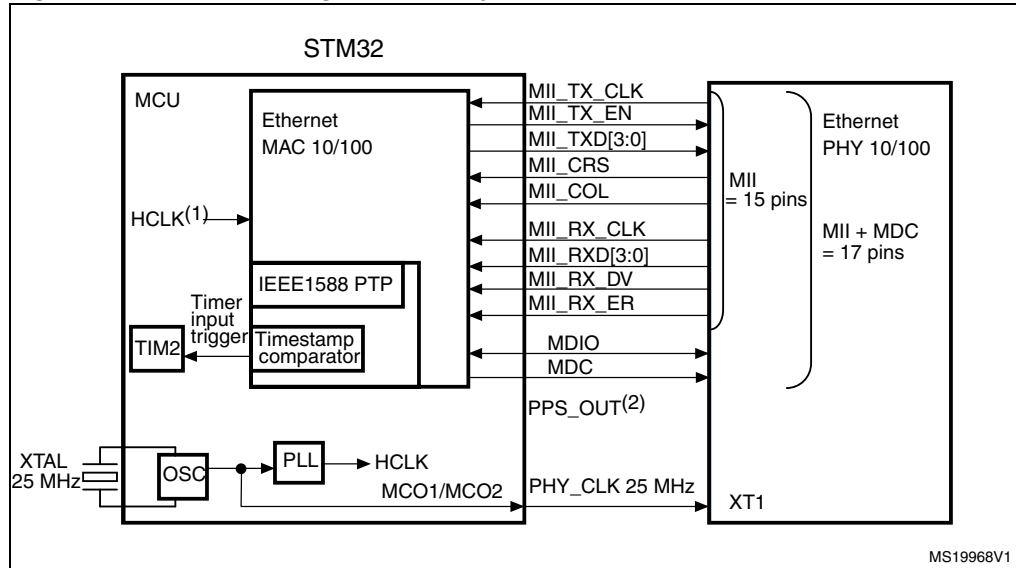
**Figure 92. Master clock (MCK) not used to drive the external audio DAC**



1. I2S\_SCK is the I2S serial clock to the external audio DAC (not to be confused with I2S\_CK).

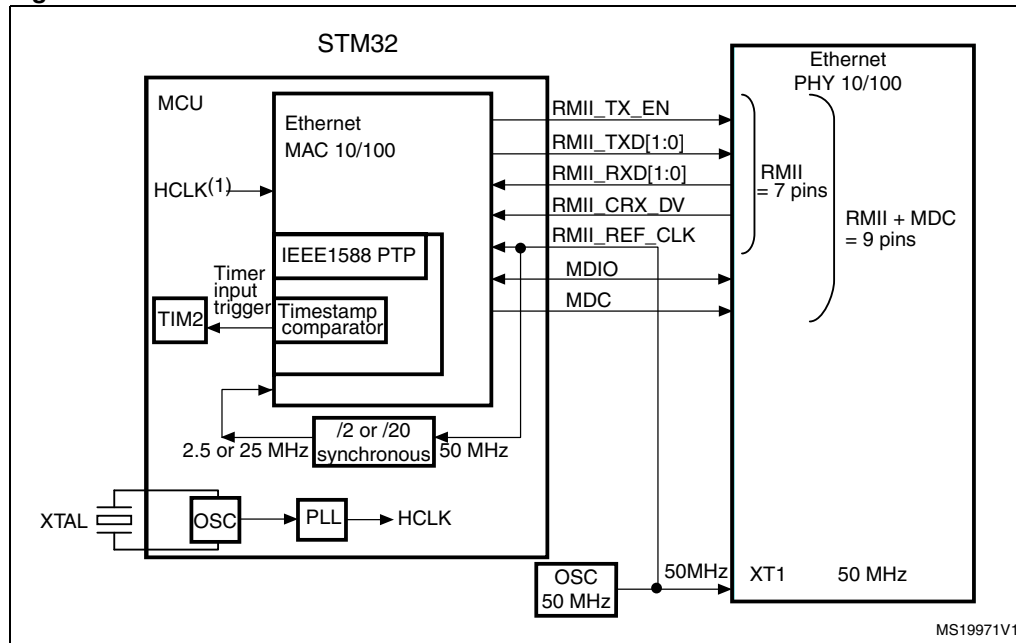
## A.6 Ethernet interface solutions

Figure 93. MII mode using a 25 MHz crystal



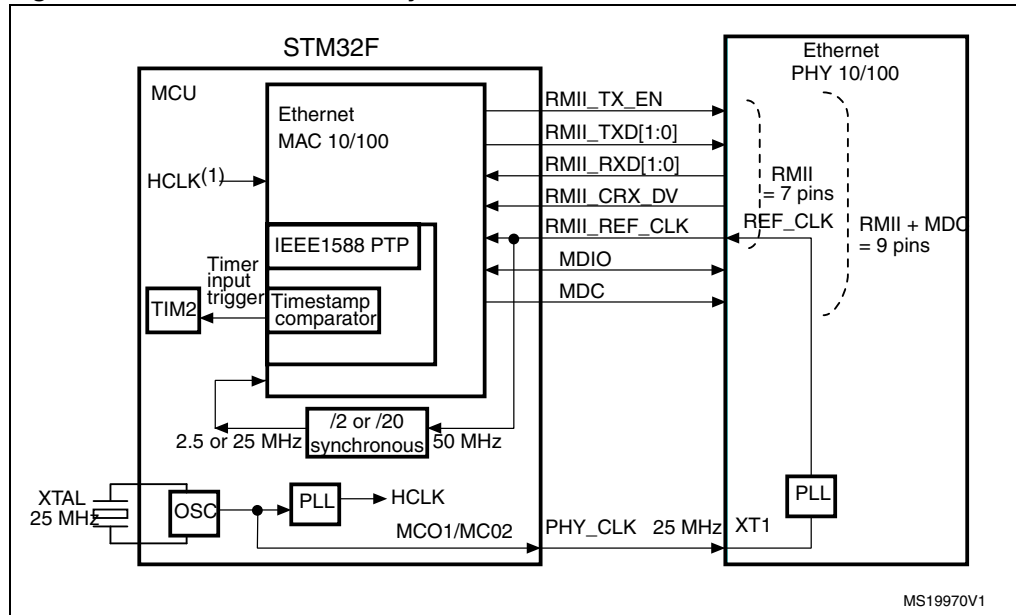
1.  $f_{HCLK}$  must be greater than 25 MHz.
2. Pulse per second when using IEEE1588 PTP optional signal.

Figure 94. RMII with a 50 MHz oscillator



1.  $f_{HCLK}$  must be greater than 25 MHz.

Figure 95. RMIi with a 25 MHz crystal and PHY with PLL



1.  $f_{HCLK}$  must be greater than 25 MHz.
2. The 25 MHz (PHY\_CLK) must be derived directly from the HSE oscillator, before the PLL block.

## 8 Revision history

Table 91. Document revision history

Date	Revision	Changes
02-Feb-2010	1	Initial release.
13-Jul-2010	2	<p>Updated datasheet status to PRELIMINARY DATA. Renamed high-speed SRAM, system SRAM. Added UFBGA176 package, and note 1 related to LQFP176 package in <a href="#">Table 2</a>, <a href="#">Figure 12</a>, and <a href="#">Table 89</a>. Added information on ART accelerator and audio PLL (PLLI2S). Added <a href="#">Table 4: USART feature comparison</a>. Several updates on <a href="#">Table 5: STM32F21x pin and ball definitions</a> and <a href="#">Table 6: Alternate function mapping</a>. ADC, DAC, oscillator, RTC_AF, WKUP and VBUS signals removed from alternate functions and moved to the “other functions” column in <a href="#">Table 5: STM32F21x pin and ball definitions</a>. TRACESWO added in <a href="#">Figure 5: STM32F21x block diagram</a>, <a href="#">Table 5: STM32F21x pin and ball definitions</a>, and <a href="#">Table 6: Alternate function mapping</a>. XTAL oscillator frequency updated on cover page, in <a href="#">Figure 5: STM32F21x block diagram</a> and in <a href="#">Section 2.2.11: External interrupt/event controller (EXTI)</a>. Updated list of peripherals used for boot mode in <a href="#">Section 2.2.13: Boot modes</a>. Added Regulator bypass mode in <a href="#">Section 2.2.16: Voltage regulator</a>, and <a href="#">Section 5.3.4: Operating conditions at power-up / power-down (regulator OFF)</a>. Updated <a href="#">Section 2.2.17: Real-time clock (RTC), backup SRAM and backup registers</a>. Added <a href="#">Note Note</a>: in <a href="#">Section 2.2.18: Low-power modes</a>. Added SPI TI protocol in <a href="#">Section 2.2.23: Serial peripheral interface (SPI)</a>. Updated <a href="#">Section 2.2.28: Universal serial bus on-the-go full-speed (OTG_FS)</a>, and <a href="#">Section 2.2.29: Universal serial bus on-the-go high-speed (OTG_HS)</a>. Added <a href="#">Section 5: Electrical characteristics</a>, and <a href="#">Section 6.2: Thermal characteristics</a>. Updated <a href="#">Table 86: LQFP176 - Low profile quad flat package 24 × 24 × 1.4 mm package mechanical data</a> and <a href="#">Figure 80: LQFP176 - Low profile quad flat package 24 × 24 × 1.4 mm, package outline</a>. Added <a href="#">Table 90: Main applications versus package for STM32F2xxx microcontrollers</a> in <a href="#">A.1: Main applications versus package</a>. Updated figures in <a href="#">Appendix A.3: USB OTG full speed (FS) interface solutions</a> and <a href="#">A.4: USB OTG high speed (HS) interface solutions</a>. Updated <a href="#">Figure 89: Audio player solution using PLL, PLLI2S, USB and 1 crystal</a> and <a href="#">Figure 90: Audio PLL (PLLI2S) providing accurate I2S clock</a>. Added random number generation feature. Added trademark for ART accelerator and updated <a href="#">Section 2.2.2: Adaptive real-time memory accelerator (ART Accelerator™)</a>.</p>



Table 91. Document revision history (continued)

Date	Revision	Changes
25-Nov-2010	3	<p>Added WLCSP66 (64+2) package. Added note 1 related to LQFP176 on cover page.</p> <p>Update I/Os in <a href="#">Section : Features</a>.</p> <p>Updated <a href="#">Table 6: Multi-AHB matrix</a>.</p> <p>Added case of BOR inactivation using IRROFF on WLCSP devices in <a href="#">Section 2.2.15: Power supply supervisor</a>.</p> <p>Reworked <a href="#">Section 2.2.16: Voltage regulator</a> to clarify regulator off modes. Added <a href="#">Section 2.2.19: VBAT operation</a>.</p> <p>Modified V<sub>DD_3</sub> pin in <a href="#">Table 5: STM32F21x pin and ball definitions</a>, and added note related to the FSMC_NL pin.</p> <p>Renamed BYPASS-REG REGOFF, and add IRROFF pin.</p> <p>Changed V<sub>SS_SA</sub> to V<sub>SS</sub>, and V<sub>DD_SA</sub> pin reserved for future use.</p> <p>Updated maximum HSE crystal frequency to 26 MHz.</p> <p>USART4/5 renamed UART4/5. USART4 pins renamed UART4 in <a href="#">Table 5: STM32F21x pin and ball definitions</a>. Updated LIN and IrDA features for UART4/5 in <a href="#">Table 4: USART feature comparison</a>.</p> <p><a href="#">Section 5.2: Absolute maximum ratings</a>: Updated V<sub>IN</sub> minimum and maximum values and note for non-five-volt tolerant pins in <a href="#">Table 7: Voltage characteristics</a>. Updated I<sub>INJ(PIN)</sub> maximum values and related notes in <a href="#">Table 8: Current characteristics</a>.</p> <p>Updated V<sub>DDA</sub> minimum value in <a href="#">Table 10: General operating conditions</a>.</p> <p>Added <a href="#">Note 2</a> and updated Maximum CPU frequency in <a href="#">Table 11: Limitations depending on the operating power supply range</a>; and added <a href="#">Figure 19: Number of wait states versus fCPU and VDD range</a>.</p> <p>Renamed Brownout Low, medium and High reset thresholds, Renamed V<sub>BORL</sub>/V<sub>BORM</sub>/V<sub>BORH</sub>, V<sub>BOR1</sub>/V<sub>BOR2</sub>/V<sub>BOR3</sub> in <a href="#">Table 15: Embedded reset and power control block characteristics</a>.</p> <p>Changed f<sub>LSI</sub> typical value in <a href="#">Table 29: LSI oscillator characteristics</a>. Added <a href="#">Figure 33: ACCLSI versus temperature</a>.</p> <p>Changed f<sub>OSC_IN</sub> maximum value in <a href="#">Table 26: HSE 4-26 MHz oscillator characteristics</a>.</p> <p>Changed f<sub>PLL_IN</sub> maximum value in <a href="#">Table 30: Main PLL characteristics</a>, and updated jitter parameters in <a href="#">Table 31: PLLI2S (audio PLL) characteristics</a>.</p> <p><a href="#">Section 5.3.16: I/O port characteristics</a>: updated V<sub>IH</sub> and V<sub>IL</sub> in <a href="#">Table 42: I/O static characteristics</a>.</p> <p>Added <a href="#">Note 1</a> below <a href="#">Table 43: Output voltage characteristics</a>.</p> <p>Updated R<sub>PD</sub> and R<sub>PU</sub> parameter description in <a href="#">Table 53: USB OTG FS DC electrical characteristics</a>.</p> <p>Updated V<sub>REF+</sub> minimum value in <a href="#">Table 62: ADC characteristics</a>.</p> <p>Updated <a href="#">Table 67: Embedded internal reference voltage</a>.</p> <p>Removed Ethernet and USB2 for 64-pin devices in <a href="#">Table 90: Main applications versus package for STM32F2xxx microcontrollers</a>.</p> <p>Added <a href="#">A.2: Application example with regulator OFF</a>, removed "OTG FS connection with external PHY" figure, updated <a href="#">Figure 84</a>, <a href="#">Figure 85</a>, and <a href="#">Figure 87</a> to add STULPI01B.</p>

Table 91. Document revision history (continued)

Date	Revision	Changes
22-Apr-2011	4	<p>Changed datasheet status to "Full Datasheet".</p> <p>APB1 frequency changed from 36 MHz to 30 MHz.</p> <p>Introduced concept of SRAM1 and SRAM2.</p> <p>LQFP176 now in production.</p> <p>Removed WLCSP64+2 package.</p> <p>Updated <a href="#">Figure 3: Compatible board design between STM32F10xx and STM32F2xx for LQFP144 package</a> and <a href="#">Figure 2: Compatible board design between STM32F10xx and STM32F2xx for LQFP100 package</a>.</p> <p>Added camera interface for STM32F217Vx devices in <a href="#">Table 2: STM32F215xx and STM32F217xx: features and peripheral counts</a>.</p> <p>Removed 16 MHz internal RC oscillator accuracy in <a href="#">Section 2.2.12: Clocks and startup</a>.</p> <p>Updated <a href="#">Section 2.2.16: Voltage regulator</a>.</p> <p>Modified I<sup>2</sup>S sampling frequency range in <a href="#">Section 2.2.12: Clocks and startup</a>, <a href="#">Section 2.2.24: Inter-integrated sound (I2S)</a>, and <a href="#">Section 2.2.30: Audio PLL (PLL12S)</a>.</p> <p>Updated <a href="#">Section 2.2.17: Real-time clock (RTC), backup SRAM and backup registers</a> and description of TIM2 and TIM5 in <a href="#">Section : General-purpose timers (TIMx)</a>.</p> <p>Modified maximum baud rate (oversampling by 16) for USART1 in <a href="#">Table 4: USART feature comparison</a>.</p> <p>Updated note related to RFU pin below <a href="#">Figure 10: STM32F21x LQFP100 pinout</a>, <a href="#">Figure 11: STM32F21x LQFP144 pinout</a>, <a href="#">Figure 12: STM32F21x LQFP176 pinout</a>, <a href="#">Figure 13: STM32F21x UFBGA176 ballout</a>, and <a href="#">Table 5: STM32F21x pin and ball definitions</a>.</p> <p>Added RTC_50Hz as PB15 alternate function, and TT (3.6 V tolerant I/O) in <a href="#">Table 5: STM32F21x pin and ball definitions</a> and <a href="#">Table 6: Alternate function mapping</a>.</p> <p>PA15 added in <a href="#">Table 5: STM32F21x pin and ball definitions</a>.</p> <p>In <a href="#">Table 5: STM32F21x pin and ball definitions</a>, changed I2S2_CK and I2S3_CK to I2S2_SCK and I2S3_SCK, respectively.</p> <p>Removed ETH_RMII_TX_CLK for PC3/AF11 in <a href="#">Table 6: Alternate function mapping</a>.</p> <p>Updated <a href="#">Table 7: Voltage characteristics</a> and <a href="#">Table 8: Current characteristics</a>.</p> <p>T<sub>STG</sub> updated to -65 to +150 in <a href="#">Table 9: Thermal characteristics</a>.</p> <p>Added CEXT and ESR in <a href="#">Table 10: General operating conditions</a> as well as <a href="#">Section 5.3.2: VCAP1/VCAP2 external capacitor</a>.</p> <p>Modified <a href="#">Note 3</a> in <a href="#">Table 11: Limitations depending on the operating power supply range</a>.</p> <p>Updated <a href="#">Table 13: Operating conditions at power-up / power-down (regulator ON)</a>, and <a href="#">Table 14: Operating conditions at power-up / power-down (regulator OFF)</a>.</p> <p>Added OSC_OUT pin in <a href="#">Figure 15: Pin loading conditions</a>. and <a href="#">Figure 16: Pin input voltage</a>.</p> <p>Updated notes below <a href="#">Figure 15: Pin loading conditions</a>.</p> <p>Updated V<sub>PVD</sub>, V<sub>BOR1</sub>, V<sub>BOR2</sub>, V<sub>BOR3</sub>, T<sub>RSTTEMPO</sub> typical value, and I<sub>RUSH</sub>, added E<sub>RUSH</sub> and <a href="#">Note 3</a> in <a href="#">Table 15: Embedded reset and power control block characteristics</a>.</p>

Table 91. Document revision history (continued)

Date	Revision	Changes
22-Apr-2011	4 (continued)	<p>Updated <i>Typical and maximum current consumption</i> conditions, as well as <i>Table 16: Typical and maximum current consumption in Run mode, code with data processing running from Flash memory (ART accelerator disabled)</i> and <i>Table 17: Typical and maximum current consumption in Run mode, code with data processing running from Flash memory (ART accelerator enabled) or RAM</i>. Added <i>Figure 21, Figure 22, Figure 23, and Figure 24</i>.</p> <p>Updated <i>Table 18: Typical and maximum current consumption in Sleep mode</i>, and added <i>Figure 25 and Figure 26</i>.</p> <p>Updated <i>Table 20: Typical and maximum current consumptions in Standby mode</i> and <i>Table 21: Typical and maximum current consumptions in VBAT mode</i>.</p> <p>Updated <i>Table 19: Typical and maximum current consumptions in Stop mode</i>. Added <i>Figure 27: Typical current consumption vs temperature in Stop mode</i>.</p> <p>Updated <i>Table 20: Typical and maximum current consumptions in Standby mode</i> and <i>Table 21: Typical and maximum current consumptions in VBAT mode</i>.</p> <p>Updated <i>On-chip peripheral current consumption</i> conditions and <i>Table 22: Peripheral current consumption</i>.</p> <p>Updated <math>t_{WUSTDBY}</math> and <math>t_{WUSTOP}</math> and added <i>Note 3</i> in <i>Table 23: Low-power mode wakeup timings</i>.</p> <p>Maximum <math>f_{HSE\_ext}</math> and minimum <math>t_{w(HSE)}</math> values updated in <i>Table 24: High-speed external user clock characteristics</i>.</p> <p>Updated <math>C</math> and <math>g_m</math> in <i>Table 26: HSE 4-26 MHz oscillator characteristics</i>. Updated <math>R_F</math>, <math>I_2</math>, <math>g_m</math>, and <math>t_{su(LSE)}</math> in <i>Table 27: LSE oscillator characteristics (fLSE = 32.768 kHz)</i>.</p> <p>Added <i>Note 3</i> and updated <math>ACC_{HSI}</math>, <math>IDD_{(HSI)}</math> and <math>t_{su(HSI)}</math> in <i>Table 28: HSI oscillator characteristics</i>. Added <i>Figure 32: ACCHSI versus temperature</i></p> <p>Updated <math>f_{LSI}</math>, <math>t_{su(LSI)}</math> and <math>IDD_{(LSI)}</math> in <i>Table 29: LSI oscillator characteristics</i>.</p> <p><i>Table 30: Main PLL characteristics</i>: removed note 1, updated <math>t_{LOCK}</math>, jitter, <math>IDD_{(PLL)}</math> and <math>IDD_{A(PLL)}</math>, added <i>Note 2</i> for <math>f_{PLL\_IN}</math> minimum and maximum values.</p> <p><i>Table 31: PLLI2S (audio PLL) characteristics</i>: removed note 1, updated <math>t_{LOCK}</math>, jitter, <math>IDD_{(PLLI2S)}</math> and <math>IDD_{A(PLLI2S)}</math>, added <i>Note 3</i> for <math>f_{PLLI2S\_IN}</math> minimum and maximum values.</p> <p>Added <i>Note 1</i> in <i>Table 32: SSCG parameters constraint</i>.</p> <p>Updated <i>Table 33: Flash memory characteristics</i>. Modified <i>Table 34: Flash memory programming</i> and added <i>Note 2</i> for <math>t_{prog}</math>. Updated <math>t_{prog}</math> and added <i>Note 2</i> in <i>Table 35: Flash memory programming with VPP</i>.</p> <p>Modified <i>Figure 37: Recommended NRST pin protection</i>.</p> <p>Updated <i>Table 38: EMI characteristics</i> and EMI monitoring conditions in <i>Section : Electromagnetic Interference (EMI)</i>.</p> <p>Added <i>Note 2</i> related to <math>V_{ESD(HBM)}</math> in <i>Table 39: ESD absolute maximum ratings</i>.</p> <p>Added <i>Section 5.3.15: I/O current injection characteristics</i>.</p> <p>Updated <i>Table 42: I/O static characteristics</i>. Modified maximum frequency values and conditions in <i>Table 44: I/O AC characteristics</i>.</p>

Table 91. Document revision history (continued)

Date	Revision	Changes
22-Apr-2011	4 (continued)	<p>Updated <math>t_{res(TIM)}</math> in <a href="#">Table 46: Characteristics of TIMx connected to the APB1 domain</a>. Modified <math>t_{res(TIM)}</math> and <math>f_{EXT}</math> <a href="#">Table 47: Characteristics of TIMx connected to the APB2 domain</a>.</p> <p>Changed <math>t_{w(SCKH)}</math> to <math>t_{w(SCLH)}</math>, <math>t_{w(SCKL)}</math> to <math>t_{w(SCLL)}</math>, <math>t_r(SCK)</math> to <math>t_r(SCL)</math>, and <math>t_f(SCK)</math> to <math>t_f(SCL)</math> in <a href="#">Table 48: I2C characteristics</a> and <a href="#">Figure 38: I2C bus AC waveforms and measurement circuit</a>.</p> <p>Added <a href="#">Table 53: USB OTG FS DC electrical characteristics</a> and updated <a href="#">Table 54: USB OTG FS electrical characteristics</a>.</p> <p>Updated <math>V_{DD}</math> minimum value in <a href="#">Table 58: Ethernet DC electrical characteristics</a>.</p> <p>Updated <a href="#">Table 62: ADC characteristics</a> and <math>R_{AIN}</math> equation.</p> <p>Updated <math>R_{AIN}</math> equation. Updated <a href="#">Table 64: DAC characteristics</a>.</p> <p>Updated <math>t_{START}</math> in <a href="#">Table 65: TS characteristics</a>.</p> <p>Updated <a href="#">Table 67: Embedded internal reference voltage</a>.</p> <p>Modified FSMC_NOE waveform in <a href="#">Figure 54: Asynchronous non-multiplexed SRAM/PSRAM/NOR read waveforms</a>. Shifted end of FSMC_NEx/NADV/addresses/NWE/NOE/NWAIT of a half FSMC_CLK period, changed <math>t_{d(CLKH-NExH)}</math> to <math>t_{d(CLKL-NExH)}</math>, <math>t_{d(CLKH-AIV)}</math> to <math>t_{d(CLKL-AIV)}</math>, <math>t_{d(CLKH-NOEH)}</math> to <math>t_{d(CLKL-NOEH)}</math>, and <math>t_{d(CLKH-NWEH)}</math> to <math>t_{d(CLKL-NWEH)}</math>, and updated data latency from 1 to 0 in <a href="#">Figure 58: Synchronous multiplexed NOR/PSRAM read timings</a>, <a href="#">Figure 59: Synchronous multiplexed PSRAM write timings</a>, <a href="#">Figure 60: Synchronous non-multiplexed NOR/PSRAM read timings</a>, and <a href="#">Figure 61: Synchronous non-multiplexed PSRAM write timings</a>,</p> <p>Changed <math>t_{d(CLKH-NExH)}</math> to <math>t_{d(CLKL-NExH)}</math>, <math>t_{d(CLKH-AIV)}</math> to <math>t_{d(CLKL-AIV)}</math>, <math>t_{d(CLKH-NOEH)}</math> to <math>t_{d(CLKL-NOEH)}</math>, <math>t_{d(CLKH-NWEH)}</math> to <math>t_{d(CLKL-NWEH)}</math>, and modified <math>t_w(CLK)</math> minimum value in <a href="#">Table 72</a>, <a href="#">Table 73</a>, <a href="#">Table 74</a>, and <a href="#">Table 75</a>.</p> <p>Updated R typical value in <a href="#">Table 66: VBAT monitoring characteristics</a>. Updated note 2 in <a href="#">Table 68</a>, <a href="#">Table 69</a>, <a href="#">Table 70</a>, <a href="#">Table 71</a>, <a href="#">Table 72</a>, <a href="#">Table 73</a>, <a href="#">Table 74</a>, and <a href="#">Table 75</a>.</p> <p>Modified <math>t_{h(NIOWR-D)}</math> in <a href="#">Figure 67: PC Card/CompactFlash controller waveforms for I/O space write access</a>.</p> <p>Modified FSMC_NCEX signal in <a href="#">Figure 68: NAND controller waveforms for read access</a>, <a href="#">Figure 69: NAND controller waveforms for write access</a>, <a href="#">Figure 70: NAND controller waveforms for common memory read access</a>, and <a href="#">Figure 71: NAND controller waveforms for common memory write access</a>.</p> <p>Specified Full speed (FS) mode for <a href="#">Figure 86: USB OTG HS peripheral-only connection in FS mode</a> and <a href="#">Figure 87: USB OTG HS host-only connection in FS mode</a>.</p>

Table 91. Document revision history (continued)

Date	Revision	Changes
14-Jun-2011	5	<p>Added SDIO in <a href="#">Table 2: STM32F215xx and STM32F217xx: features and peripheral counts</a>.</p> <p>Updated <math>V_{IN}</math> for 5V tolerant pins in <a href="#">Table 7: Voltage characteristics</a>.</p> <p>Updated jitter parameters description in <a href="#">Table 30: Main PLL characteristics</a>.</p> <p>Remove jitter values for system clock in <a href="#">Table 31: PLLI2S (audio PLL) characteristics</a>.</p> <p>Updated <a href="#">Table 38: EMI characteristics</a>.</p> <p>Update <a href="#">Note 2</a> in <a href="#">Table 48: I2C characteristics</a>.</p> <p>Updated Avg_Slope typical value and <math>T_{S\_temp}</math> minimum value in <a href="#">Table 65: TS characteristics</a>.</p> <p>Updated <math>T_{S\_vbat}</math> minimum value in <a href="#">Table 66: VBAT monitoring characteristics</a>.</p> <p>Updated <math>T_{S\_vrefint}</math> minimum value in <a href="#">Table 67: Embedded internal reference voltage</a>.</p> <p>Added Software option in <a href="#">Section 7: Part numbering</a>.</p> <p>In <a href="#">Table 90: Main applications versus package for STM32F2xxx microcontrollers</a>, renamed USB1 and USB2, USB OTG FS and USB OTG HS, respectively; and removed USB OTG FS and camera interface for 64-pin package; added USB OTG HS on 64-pin package; and added <a href="#">Note 2</a> and <a href="#">Note 3</a>.</p> <p>Updated disclaimer on cover page.</p>

Table 91. Document revision history (continued)

Date	Revision	Changes
20-Dec-2011	6	<p>Updated SDIO register addresses in <a href="#">Figure 14: Memory map</a>.</p> <p>Updated <a href="#">Figure 3: Compatible board design between STM32F10xx and STM32F2xx for LQFP144 package</a>, <a href="#">Figure 2: Compatible board design between STM32F10xx and STM32F2xx for LQFP100 package</a>, <a href="#">Figure 1: Compatible board design between STM32F10xx and STM32F2xx for LQFP64 package</a>, and added <a href="#">Figure 4: Compatible board design between STM32F10xx and STM32F2xx for LQFP176 package</a>.</p> <p>Updated <a href="#">Section 2.2.3: Memory protection unit</a>.</p> <p>Updated <a href="#">Section 2.2.6: Embedded SRAM</a>.</p> <p>Updated <a href="#">Section 2.2.28: Universal serial bus on-the-go full-speed (OTG_FS)</a> to remove external FS OTG PHY support.</p> <p>In <a href="#">Table 5: STM32F21x pin and ball definitions</a>: changed SPI2_MCK and SPI3_MCK to I2S2_MCK and I2S3_MCK, respectively. Added ETH_RMII_TX_EN alternate function to PG11. Added EVENTOUT in the list of alternate functions for I/O pin/balls. Removed OTG_FS_SDA, OTG_FS_SCL and OTG_FS_INTN alternate functions.</p> <p>In <a href="#">Table 6: Alternate function mapping</a>: changed I2S3_SCK to I2S3_MCK for PC7/AF6, added FSMC_NCE3 for PG9, FSMC_NE3 for PG10, and FSMC_NCE2 for PD7. Removed OTG_FS_SDA, OTG_FS_SCL and OTG_FS_INTN alternate functions. Updated peripherals corresponding to AF12.</p> <p>Removed CEXT and ESR from <a href="#">Table 10: General operating conditions</a>.</p> <p>Added maximum power consumption at <math>T_A=25\text{ }^\circ\text{C}</math> in <a href="#">Table 19: Typical and maximum current consumptions in Stop mode</a>.</p> <p>Added CRYPTO, RNG, and HASH consumption in <a href="#">Table 22: Peripheral current consumption</a>.</p> <p>Updated md minimum value in <a href="#">Table 32: SSCG parameters constraint</a>.</p> <p>Added examples in <a href="#">Section 5.3.11: PLL spread spectrum clock generation (SSCG) characteristics</a>.</p> <p>Updated <a href="#">Table 50: SPI characteristics</a> and <a href="#">Table 51: I2S characteristics</a>.</p> <p>Updated <a href="#">Figure 45: ULPI timing diagram</a> and <a href="#">Table 57: ULPI timing</a>.</p> <p>Updated <a href="#">Table 59: Dynamics characteristics: Ethernet MAC signals for SMI</a>, <a href="#">Table 60: Dynamics characteristics: Ethernet MAC signals for RMII</a>, and <a href="#">Table 61: Dynamics characteristics: Ethernet MAC signals for MII</a>.</p> <p>Updated maximum <math>f_S</math> values in <a href="#">Table 62: ADC characteristics</a>.</p> <p><a href="#">Section 5.3.25: FSMC characteristics</a>: updated <a href="#">Table 68</a> to <a href="#">Table 79</a>, changed <math>C_L</math> value to 30 pF, and modified FSMC configuration for asynchronous timings and waveforms. Updated <a href="#">Figure 59: Synchronous multiplexed PSRAM write timings</a>.</p> <p>Updated <a href="#">Table 80: DCMI characteristics</a>.</p> <p>Updated <a href="#">Table 87: UFBGA176+25 - ultra thin fine pitch ball grid array 10 × 10 × 0.6 mm mechanical data</a>.</p>

Table 91. Document revision history (continued)

Date	Revision	Changes
20-Dec-2011	6 (continued)	<p>Appendix A.3: <i>USB OTG full speed (FS) interface solutions</i>: updated <a href="#">Figure 84: USB OTG FS (full speed) host-only connection</a> and added <a href="#">Note 2</a>, updated <a href="#">Figure 85: OTG FS (full speed) connection dual-role with internal PHY</a> and added <a href="#">Note 3</a> and <a href="#">Note 4</a>, modified <a href="#">Figure 86: OTG HS (high speed) device connection, host and dual-role in high-speed mode with external PHY</a> and added <a href="#">Note 2</a>.</p> <p>Appendix A.4: <i>USB OTG high speed (HS) interface solutions</i>: removed figures <i>USB OTG HS device-only connection in FS mode</i> and <i>USB OTG HS host-only connection in FS mode</i>, updated <a href="#">Figure 86: OTG HS (high speed) device connection, host and dual-role in high-speed mode with external PHY</a>.</p> <p>Added Appendix A.6: <i>Ethernet interface solutions</i>.</p> <p>Updated disclaimer on last page.</p>

**Please Read Carefully:**

Information in this document is provided solely in connection with ST products. STMicroelectronics NV and its subsidiaries ("ST") reserve the right to make changes, corrections, modifications or improvements, to this document, and the products and services described herein at any time, without notice.

All ST products are sold pursuant to ST's terms and conditions of sale.

Purchasers are solely responsible for the choice, selection and use of the ST products and services described herein, and ST assumes no liability whatsoever relating to the choice, selection or use of the ST products and services described herein.

No license, express or implied, by estoppel or otherwise, to any intellectual property rights is granted under this document. If any part of this document refers to any third party products or services it shall not be deemed a license grant by ST for the use of such third party products or services, or any intellectual property contained therein or considered as a warranty covering the use in any manner whatsoever of such third party products or services or any intellectual property contained therein.

**UNLESS OTHERWISE SET FORTH IN ST'S TERMS AND CONDITIONS OF SALE ST DISCLAIMS ANY EXPRESS OR IMPLIED WARRANTY WITH RESPECT TO THE USE AND/OR SALE OF ST PRODUCTS INCLUDING WITHOUT LIMITATION IMPLIED WARRANTIES OF MERCHANTABILITY, FITNESS FOR A PARTICULAR PURPOSE (AND THEIR EQUIVALENTS UNDER THE LAWS OF ANY JURISDICTION), OR INFRINGEMENT OF ANY PATENT, COPYRIGHT OR OTHER INTELLECTUAL PROPERTY RIGHT.**

**UNLESS EXPRESSLY APPROVED IN WRITING BY TWO AUTHORIZED ST REPRESENTATIVES, ST PRODUCTS ARE NOT RECOMMENDED, AUTHORIZED OR WARRANTED FOR USE IN MILITARY, AIR CRAFT, SPACE, LIFE SAVING, OR LIFE SUSTAINING APPLICATIONS, NOR IN PRODUCTS OR SYSTEMS WHERE FAILURE OR MALFUNCTION MAY RESULT IN PERSONAL INJURY, DEATH, OR SEVERE PROPERTY OR ENVIRONMENTAL DAMAGE. ST PRODUCTS WHICH ARE NOT SPECIFIED AS "AUTOMOTIVE GRADE" MAY ONLY BE USED IN AUTOMOTIVE APPLICATIONS AT USER'S OWN RISK.**

Resale of ST products with provisions different from the statements and/or technical features set forth in this document shall immediately void any warranty granted by ST for the ST product or service described herein and shall not create or extend in any manner whatsoever, any liability of ST.

ST and the ST logo are trademarks or registered trademarks of ST in various countries.

Information in this document supersedes and replaces all information previously supplied.

The ST logo is a registered trademark of STMicroelectronics. All other names are the property of their respective owners.

© 2011 STMicroelectronics - All rights reserved

STMicroelectronics group of companies

Australia - Belgium - Brazil - Canada - China - Czech Republic - Finland - France - Germany - Hong Kong - India - Israel - Italy - Japan - Malaysia - Malta - Morocco - Philippines - Singapore - Spain - Sweden - Switzerland - United Kingdom - United States of America

[www.st.com](http://www.st.com)