

4

3

2

1

THIS DRAWING IS UNPUBLISHED. RELEASED FOR PUBLICATION
 © COPYRIGHT - BY - ALL RIGHTS RESERVED.

LOC	DIST	REVISIONS			
P	LTR	DESCRIPTION	DATE	DWN	APVD
		SEE SHEET 1.			

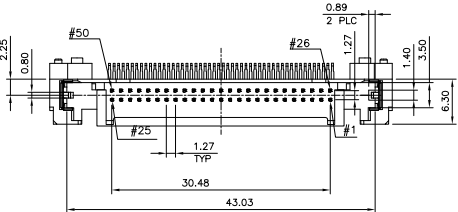

POWER	5.00mm
GENERAL	4.25mm
DETECT	3.50mm
PIN TYPE	INTERFACE DIM. L

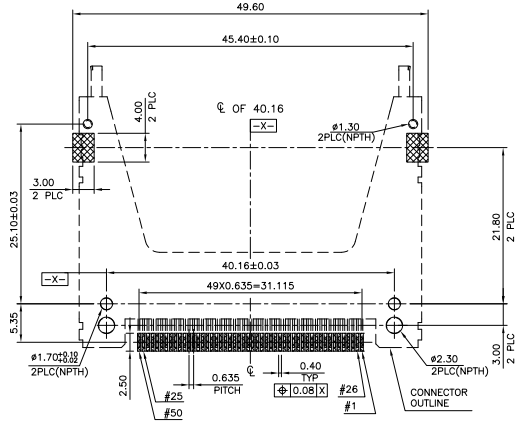
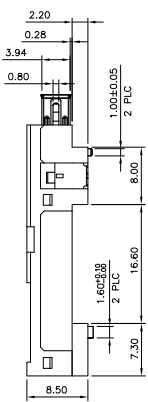
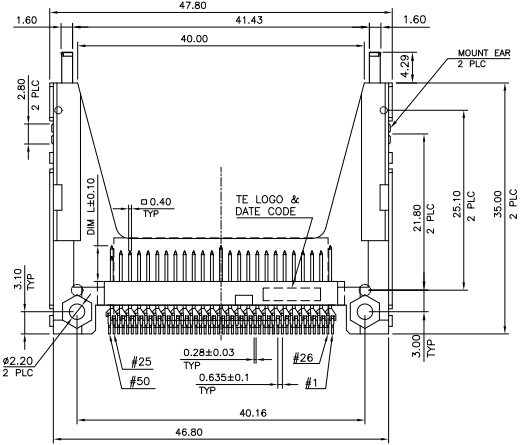

RECOMMENDED P.C.B. LAYOUT
 SOLDERING AREA (TOLERANCE: ±0.05)

- NOTE:
- MATERIAL:
 HOUSING: LCP WITH 30% GF, UL 94V-0, WHITE COLOR.
 CONTACTS: BRASS.
 MOUNT EAR: BRASS.
 GROUNDING: PHOSPHOR BRONZE.
 PICKCAP: STEEL.
 - FINISH:
 CONTACTS: 0.381µm [15µ] GOLD PLATED ON CONTACT AREA,
 2.54µm [100µ] MIN. MATTE-TIN ON SOLDER TAIL, WITH
 ENTIRE CONTACT UNDERPLATED 1.27µm [50µ] MIN. NICKEL.
 MOUNT EAR: 2.54µm [100µ] MIN. TIN PLATED ON SOLDER AREA
 1.27µm [50µ] MIN. NICKEL UNDERPLATED ALL OVER.
 GROUNDING: 2.03µm [80µ] MIN. NICKEL UNDERPLATED ALL OVER.
 3. REFLOW SOLDER CAPABLE TO 260°C PER TE CONNECTIVITY TEST SPEC.
 109-201, CONDITION B.

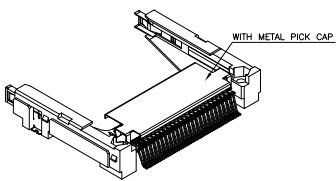
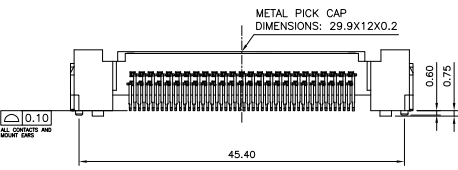

REEL	W/	1-1734450-2
PACKAGE	METAL CAP	PART NUMBER

THIS DRAWING IS A CONTROLLED DOCUMENT.		DWN	TE Connectivity	
DIMENSIONS: MM		CHK		
TOLERANCES UNLESS OTHERWISE SPECIFIED:		APVD	NAME	
0 PLC ± 0.5		PRODUCT SPEC	PIN HEADER TYPE 2, 50 POS, SMT, TOP BOARD, COMPACT FLASH CARD, STAND OFF 2.2	
1 PLC ± 0.3		QUALIFICATION TEST REPORT	RESTRICTED TO	
2 PLC ± 0.2			SIZE	CAGE CODE
3 PLC ±			A3	00779
4 PLC ±			DRAWING NO	C=1734450
ANGLES ± 2°			WEIGHT	4.64 GRAMS
MATERIAL SEE NOTE	FINISH SEE NOTE	CUSTOMER DRAWING	SCALE	SHEET 2 of 4
				REV A3

4

3

2

1

THIS DRAWING IS UNPUBLISHED. RELEASED FOR PUBLICATION
 © COPYRIGHT - BY - ALL RIGHTS RESERVED.

LOC		DIST		REVISIONS			
P	LTR	DESCRIPTION		DATE	DWN	APVD	
		SEE SHEET 1.					

TRAY
20PCS/ TRAY

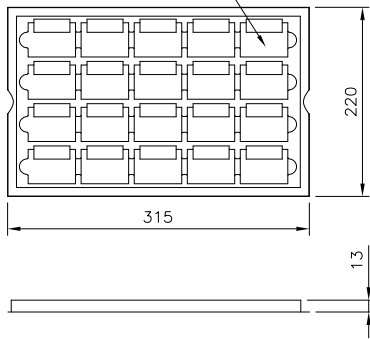

CARTON SIZE
450(L)X330(W)X254(H)

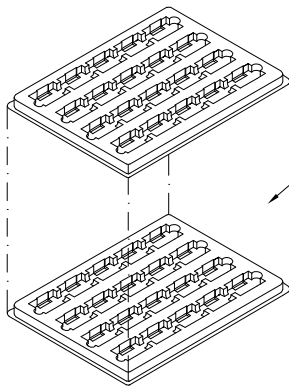
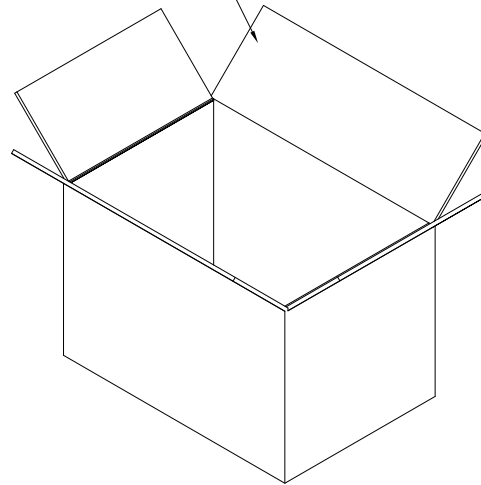

TOTAL: 41 TRAYS
TOP LAYER IS EMPTY.

7.3 Kg	6.5 Kg	800
G.W	N.W	QUANTITY

THIS DRAWING IS A CONTROLLED DOCUMENT.		DWN	STE TE Connectivity	
DIMENSIONS: MM		CHK	NAME	
TOLERANCES UNLESS OTHERWISE SPECIFIED:		APVD	PIN HEADER TYPE 2, 50 POS, SMT, TOP BOARD, COMPACT FLASH CARD, STAND OFF 2.2	
0 PLC ± -		PRODUCT SPEC	SIZE	CAGE CODE
1 PLC ± -		APPLICATION SPEC	A3	00779
2 PLC ± -		WEIGHT	DRAWING NO	
3 PLC ± -		MATERIAL	C=1734450	
4 PLC ± -		FINISH	RESTRICTED TO	
ANGLES ± -		CUSTOMER DRAWING	SCALE	SHEET
				3 of 4
				REV A3

4

3

2

1

THIS DRAWING IS UNPUBLISHED. RELEASED FOR PUBLICATION
 © COPYRIGHT - BY - ALL RIGHTS RESERVED.

LOC		DIST		REVISIONS				
P	LTR	DESCRIPTION			DATE	DWN	APVD	
DW		SEE SHEET 1.						

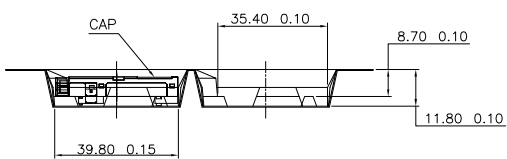
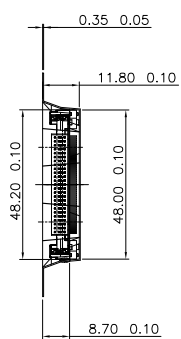
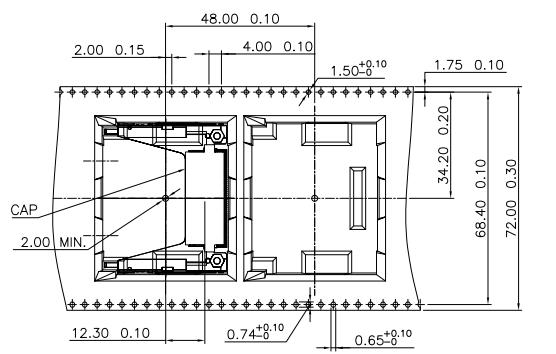
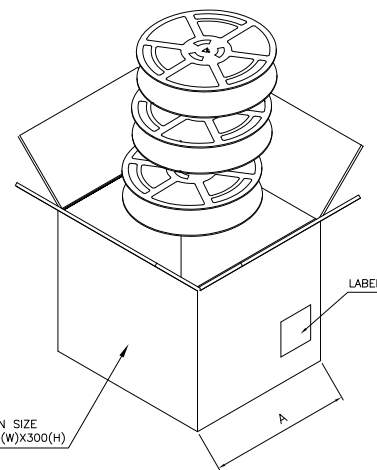
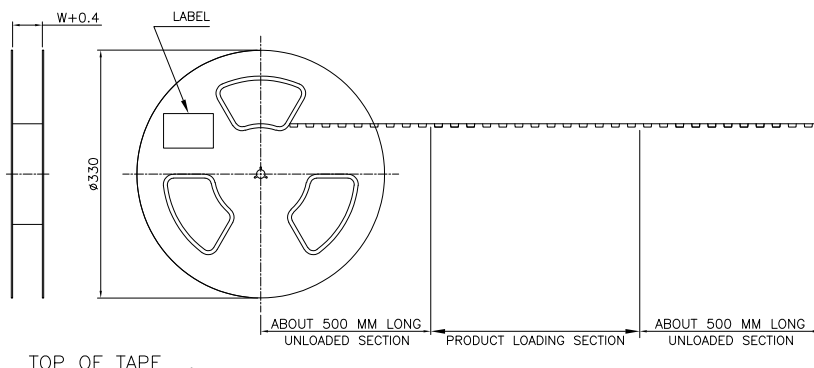

24	120	5	600	9	3.2
DIM W	PCS/REEL	REELS/CARTON	QUANTITY (PCS)	G/W (kg)	N/W (kg)

THIS DRAWING IS A CONTROLLED DOCUMENT.

DIMENSIONS: MM	TOLERANCES UNLESS OTHERWISE SPECIFIED:	DWN	CHK	 TE Connectivity PIN HEADER TYPE 2, 50 POS, SMT, TOP BOARD, COMPACT FLASH CARD, STAND OFF 2.2
0 PLC	± -	APVD	NAME	
1 PLC	± -	PRODUCT SPEC	SIZE	
2 PLC	± -	APPLICATION SPEC	CAGE CODE	
3 PLC	± -	WEIGHT	DRAWING NO	RESTRICTED TO
4 PLC	± -	CUSTOMER DRAWING	A3 00779 C=1734450	SCALE
ANGLES	± -	SCALE	SHEET	REV
MATERIAL	FINISH	4 of 4		A3