

340MHz single-supply triple video buffer

Features

- Bandwidth: 340MHz
- 5V single-supply operation
- Low output rail guaranteed at 60mV max
- Internal gain of 6dB for a matching between 3 channels
- Very low harmonic distortion
- Slew rate: 740V/ms
- Specified for 150Ω and 100Ω loads
- Tested on 5V power supply
- Min. and max. data tested during production

Applications

- High-end video systems
- High definition TV (HDTV)
- Broadcast and graphic video
- Multimedia products

Description

The TSH344 is a triple single-supply video buffer featuring an internal gain of 6dB and a large bandwidth of 340MHz.

The main advantage of this buffer is its very low output rail very close to GND when supplied in single supply 0/5V. This output rail is guaranteed by test at 60mV from GND on 150Ω. This datasheet gives technical information on using the TSH344 as an RGB driver for video DAC output on a video line. See the TSH343 datasheet for Y-Pb-Pr signals.

The TSH344 is available in the compact SO8 plastic package for optimum space-saving.

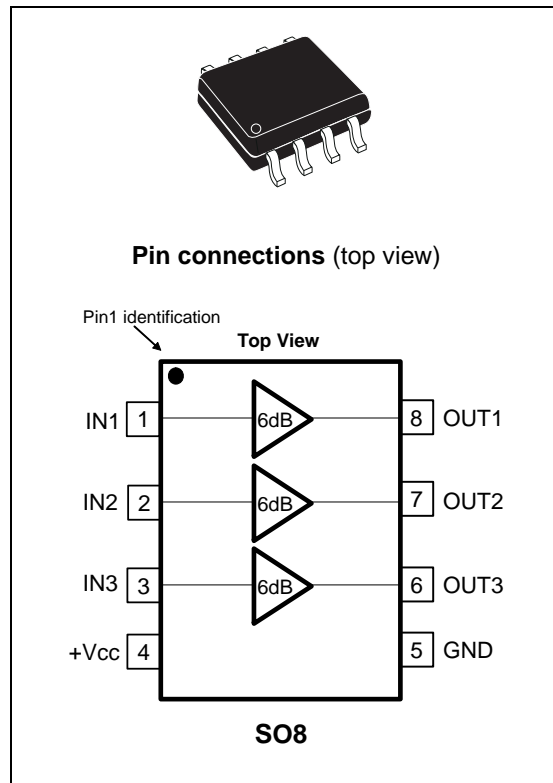

Contents

1	Absolute maximum ratings and operating conditions	3
2	Electrical characteristics	4
3	Application information	10
3.1	Using the TSH344 to drive R-G-B video components	10
3.2	Power supply considerations	12
3.3	Delay between channels	13
4	Package information	14
5	Ordering information	16
6	Revision history	16

1 Absolute maximum ratings and operating conditions

Table 1. Absolute maximum ratings (AMR)

Symbol	Parameter	Value	Unit
V_{CC}	Supply voltage ⁽¹⁾	6	V
V_{in}	Input voltage range ⁽²⁾	0 to +2	V
T_{oper}	Operating free air temperature range	-40 to +85	°C
T_{stg}	Storage temperature	-65 to +150	°C
T_j	Maximum junction temperature	150	°C
R_{thjc}	SO8 thermal resistance junction to case	28	°C/W
R_{thja}	SO8 thermal resistance junction to ambient area	157	°C/W
P_{max}	Maximum power dissipation (@ $T_{amb}=25^{\circ}C$) for $T_j=150^{\circ}C$	800	mW
ESD	CDM: charged device model	2	kV
	HBM: human body model	1.5	kV
	MM: machine model	200	V

1. All voltage values, except differential voltage, are with respect to network terminal.
2. The magnitude of input and output voltage must never exceed $V_{CC} + 0.3V$.

Table 2. Operating conditions

Symbol	Parameter	Value	Unit
V_{CC}	Power supply voltage ⁽¹⁾	3 to 5.5	V

1. Tested in full production at 0V/5V single power supply.

2 Electrical characteristics

Table 3. $V_{CC} = +5V$ single supply, $T_{amb} = 25^{\circ}C$ (unless otherwise specified)

Symbol	Parameter	Test conditions	Min.	Typ.	Max.	Unit
DC performance						
V_{OS}	Output offset voltage ⁽¹⁾	No load, T_{amb}	-35	-8	+35	mV
		$-40^{\circ}C < T_{amb} < +85^{\circ}C$		-8.6		
I_{ib}	Input bias current	T_{amb} , input to GND		5.5	16	μA
		$-40^{\circ}C < T_{amb} < +85^{\circ}C$		6		
R_{in}	Input resistance	T_{amb}		4		$G\Omega$
C_{in}	Input capacitance	T_{amb}		1		pF
PSRR	Power supply rejection ratio $20 \log (\Delta V_{CC} / \Delta V_{out})^{(2)}$	Input to GND, $F=1MHz$, $\Delta V_{CC}=200mV$		-90		dB
ICC	Supply current per buffer	No load, input to GND		10.1	13	mA
		$-40^{\circ}C < T_{amb} < +85^{\circ}C$		10.3		
G	DC voltage gain	$R_L = 150\Omega$, $V_{in}=1V$	1.92	2	2.05	V/V
MG1	Gain matching between 3 channels	Input = 1V		0.5	2	%
MG0.3	Gain matching between 3 channels	Input = 0.3V		0.5	2	%
Dynamic performance and output characteristics						
Bw	-3dB bandwidth	Small signal $V_{out}=20mVp$ $V_{icm}=0.6V$, $R_L = 150\Omega$	190	340		MHz
	Gain flatness @ 0.1dB	Small signal $V_{out}=20mVp$ $V_{icm}=0.6V$, $R_L = 150\Omega$		65		
FPBW	Full power bandwidth	$V_{icm}=0.6V$, $V_{out} = 2Vp-p$, $R_L = 150\Omega$	130	200		MHz
D	Delay between each channel	0 to 30MHz		0.5		ns
SR	Slew rate ⁽³⁾	$V_{icm}=0.6V$, $V_{out} = 2Vp-p$, $R_L = 150\Omega$	500	740		V/ μs
V_{OH}	High level output voltage	$R_L = 150\Omega$	3.7	3.9		V
V_{OL}	Low level output voltage	$R_L = 150\Omega$		40	60	mV
I_{OUT}	Output current	$V_{out}= 2Vp$, T_{amb}	45	93		mA
		$-40^{\circ}C < T_{amb} < +85^{\circ}C$		83		
	Output short circuit current (I_{source})			100		mA

Table 3. $V_{CC} = +5V$ single supply, $T_{amb} = 25^{\circ}C$ (unless otherwise specified)

Symbol	Parameter	Test conditions	Min.	Typ.	Max.	Unit
Noise and distortion						
eN	Total input voltage noise	$F = 100kHz, R_{in} = 50\Omega$		8		nV/ \sqrt{Hz}
		$R_{in} = 50\Omega$ $Bw=30MHz$ $Bw=100MHz$		55 100		μV_{rms}
HD2	2nd harmonic distortion	$V_{out} = 2V_{p-p}, R_L = 150\Omega$ $F = 10MHz$ $F = 30MHz$		-57 -42		dBc
HD3	3rd harmonic distortion	$V_{out} = 2V_{p-p}, R_L = 150\Omega$ $F = 10MHz$ $F = 30MHz$		-72 -51		dBc

1. Output offset voltage is determined by the following expression: $V_{OUT} = G \cdot V_{IN} + V_{OS}$.
2. See [Figure 28](#) and [Figure 29](#).
3. Non-tested value, guaranteed by design and evaluation. See [Figure 12](#).

Figure 1. Frequency response

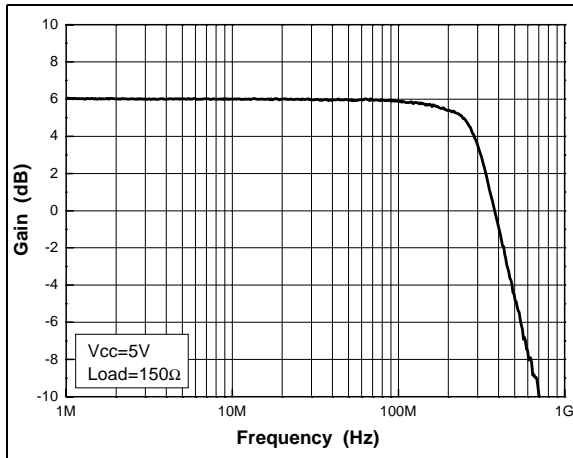

Figure 2. Gain flatness

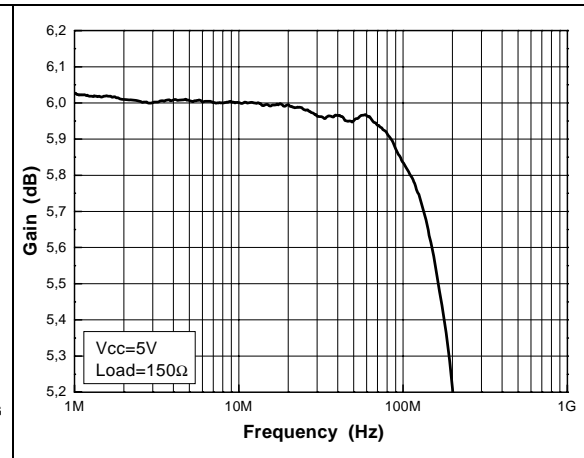

Figure 3. Cross-talk vs. frequency (amp1)

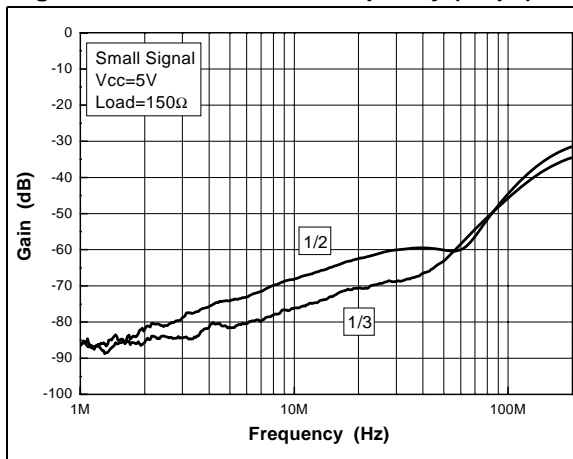

Figure 4. Cross-talk vs. frequency (amp2)

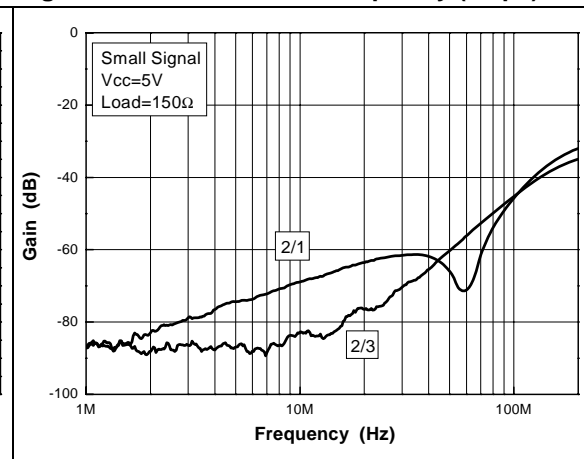

Figure 5. Cross-talk vs. frequency (amp3)

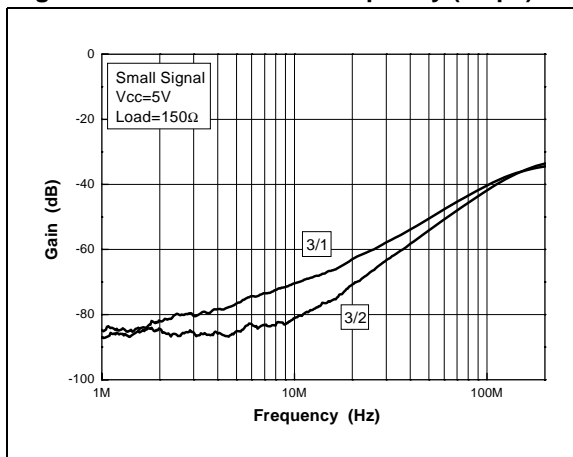

Figure 6. Input noise vs. frequency

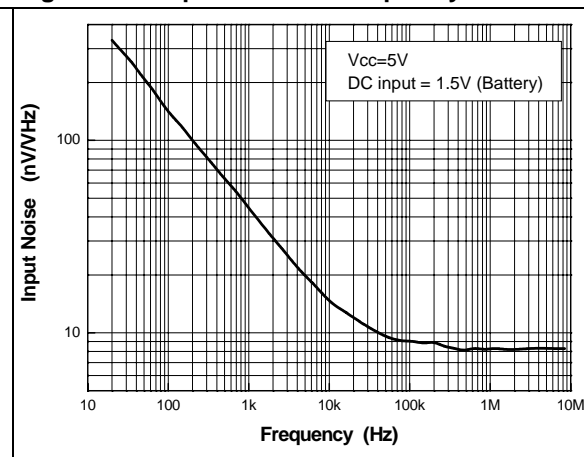

Figure 7. Distortion on 150Ω load - 10MHz

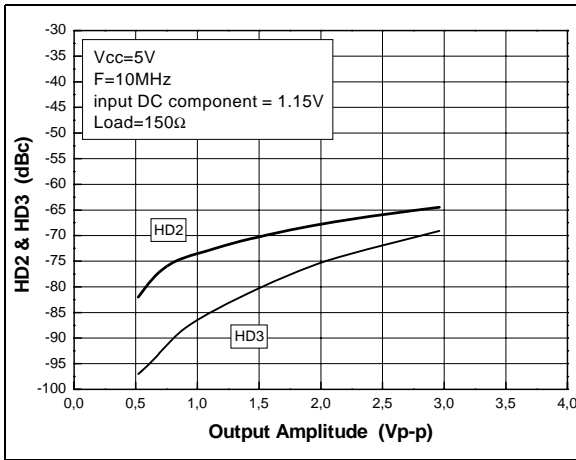

Figure 8. Distortion on 100Ω load - 10MHz

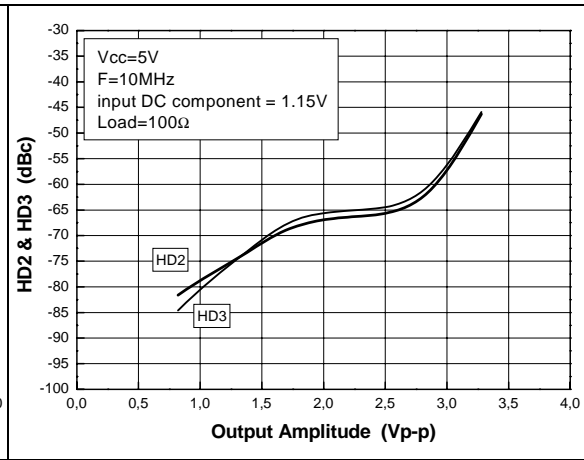

Figure 9. Distortion on 150Ω load - 30MHz

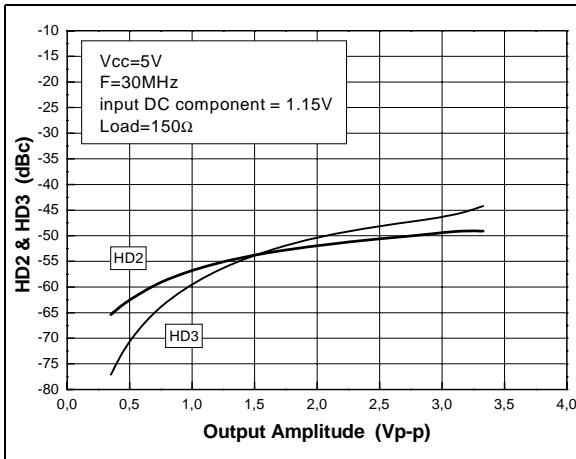

Figure 10. Distortion on 100Ω load - 30MHz

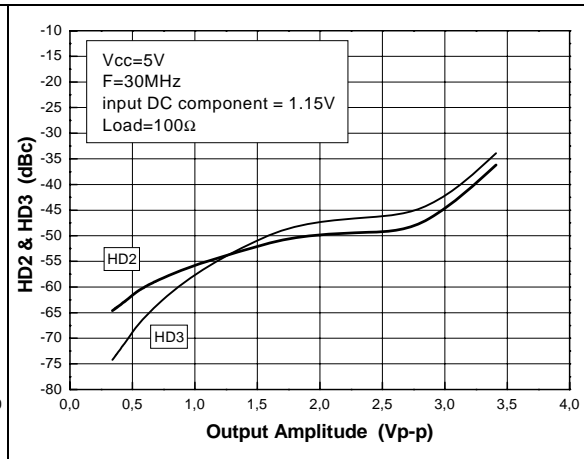

Figure 11. Output current

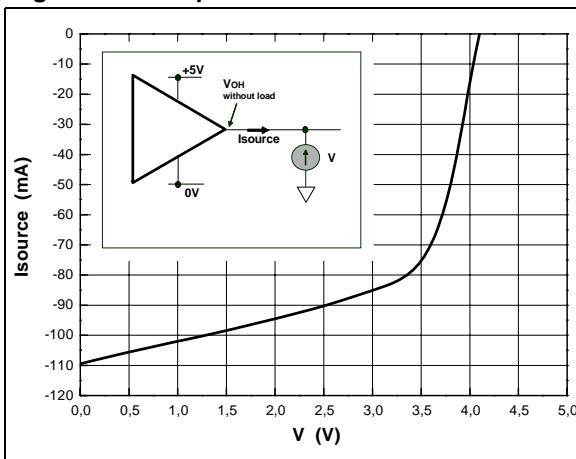

Figure 12. Slew rate

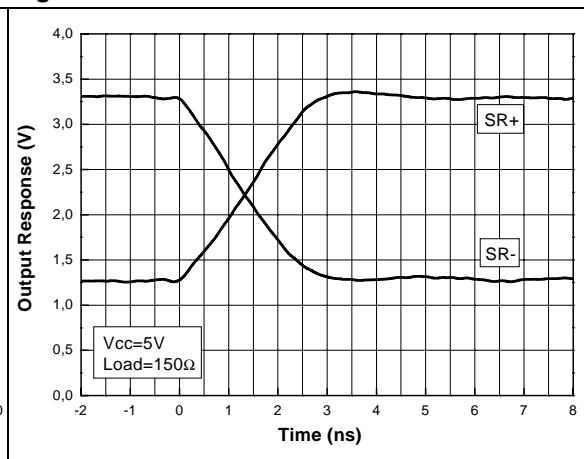

Figure 13. Reverse isolation vs. frequency

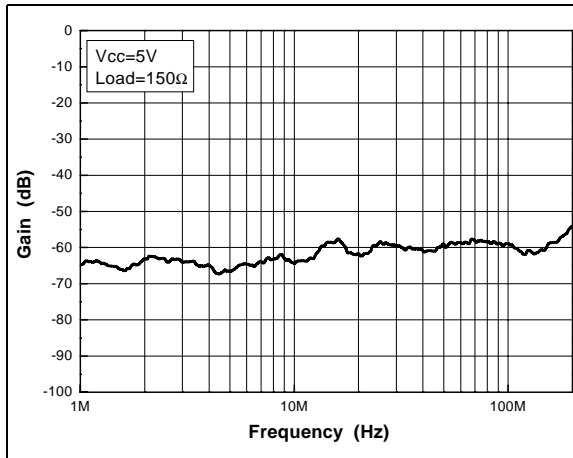

Figure 14. Output swing vs. frequency

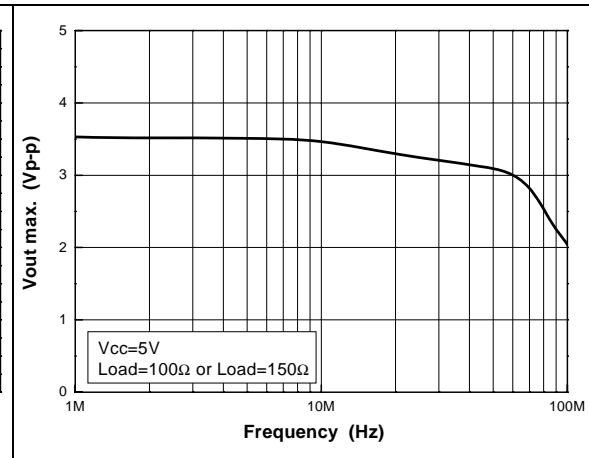

Figure 15. Quiescent current vs. supply

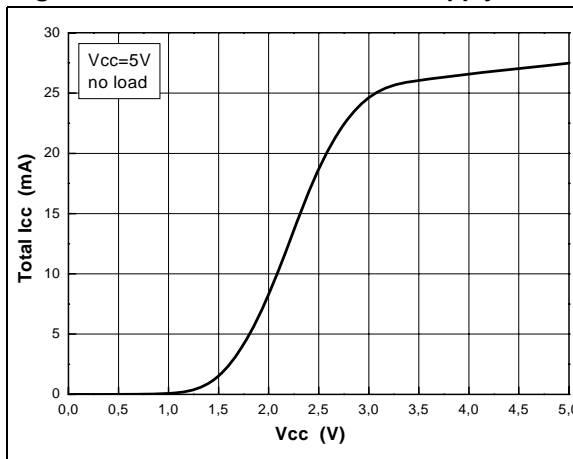

Figure 16. Output swing vs. supply

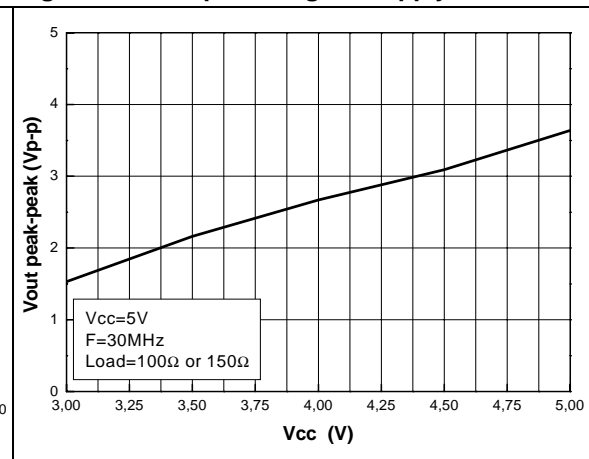

Figure 17. Bandwidth vs. temperature

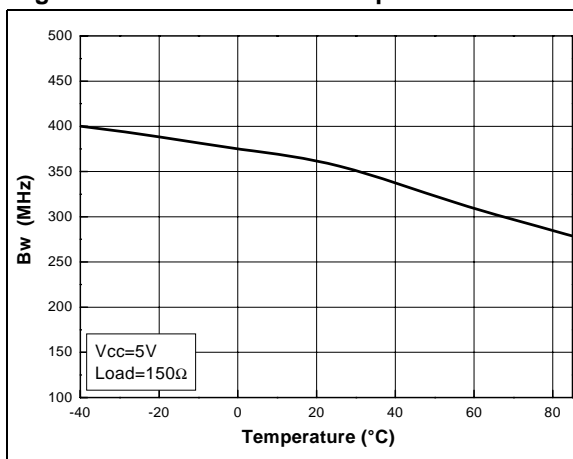

Figure 18. Voltage gain vs. temperature

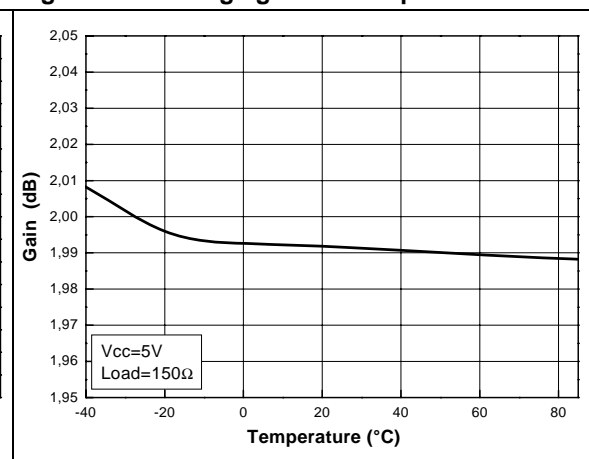

Figure 19. I_{bias} vs. temperature

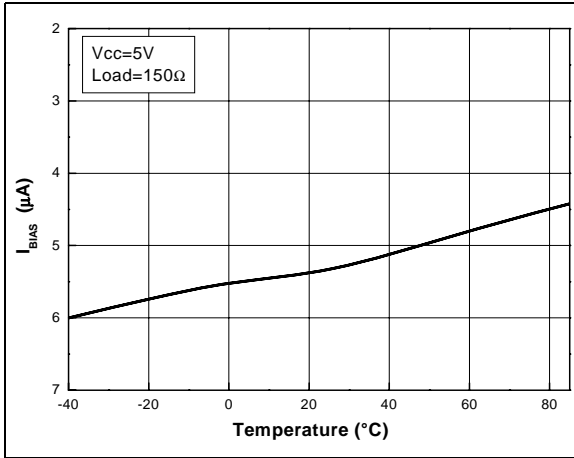

Figure 20. Gain matching vs. temperature

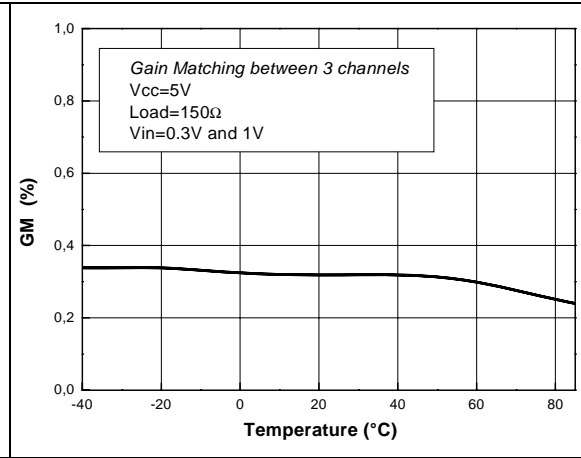

Figure 21. Supply current vs. temperature

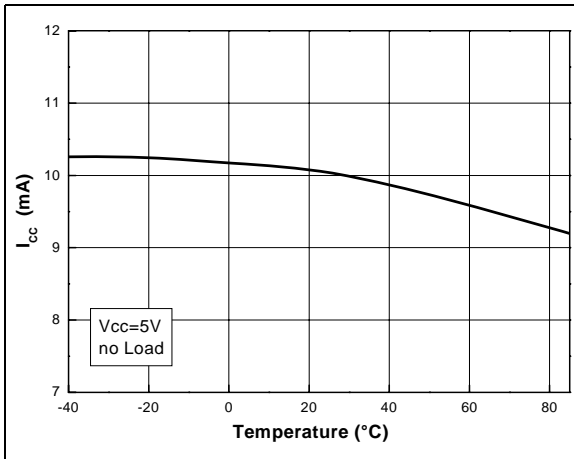

Figure 22. Output current vs. temperature

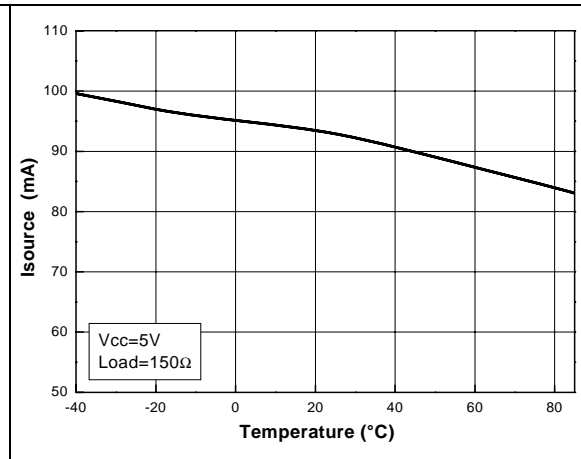

Figure 23. Output higher rail vs. temperature

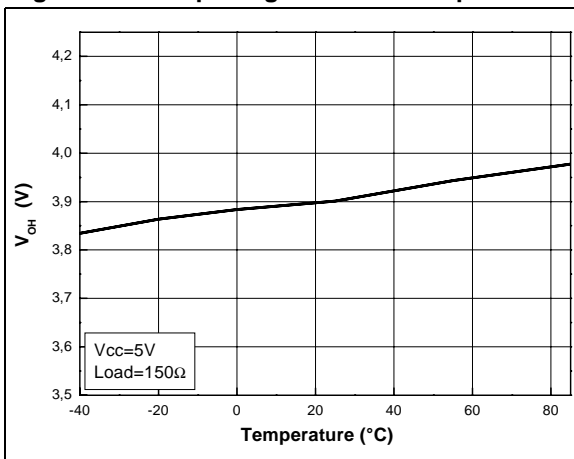
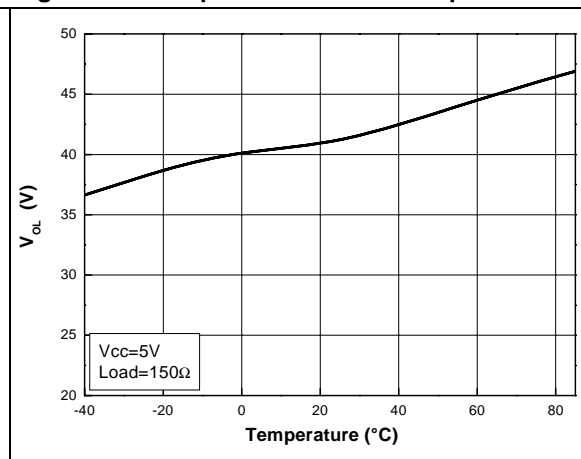

Figure 24. Output lower rail vs. temperature



3 Application information

3.1 Using the TSH344 to drive R-G-B video components

Figure 25. Shapes of video signals coming from DACs

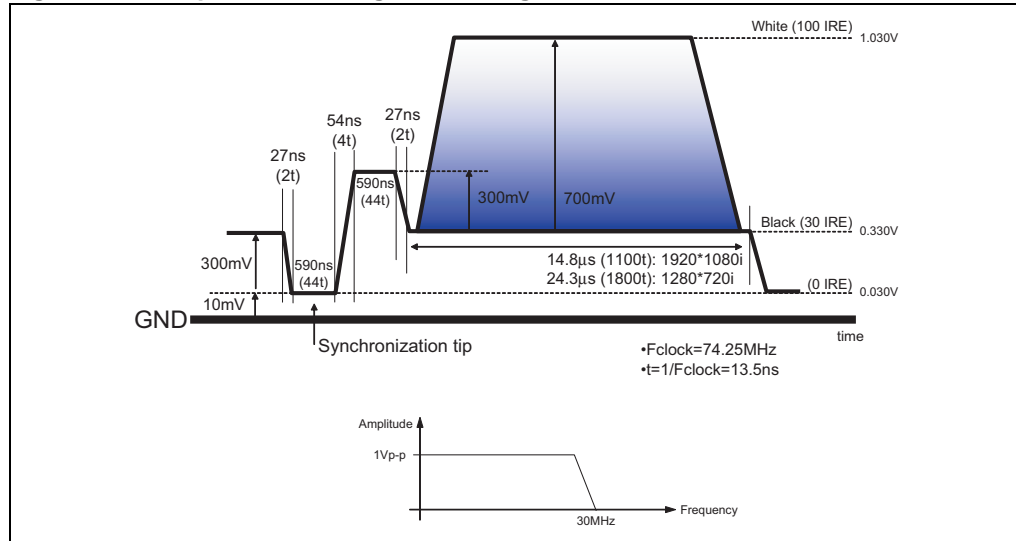
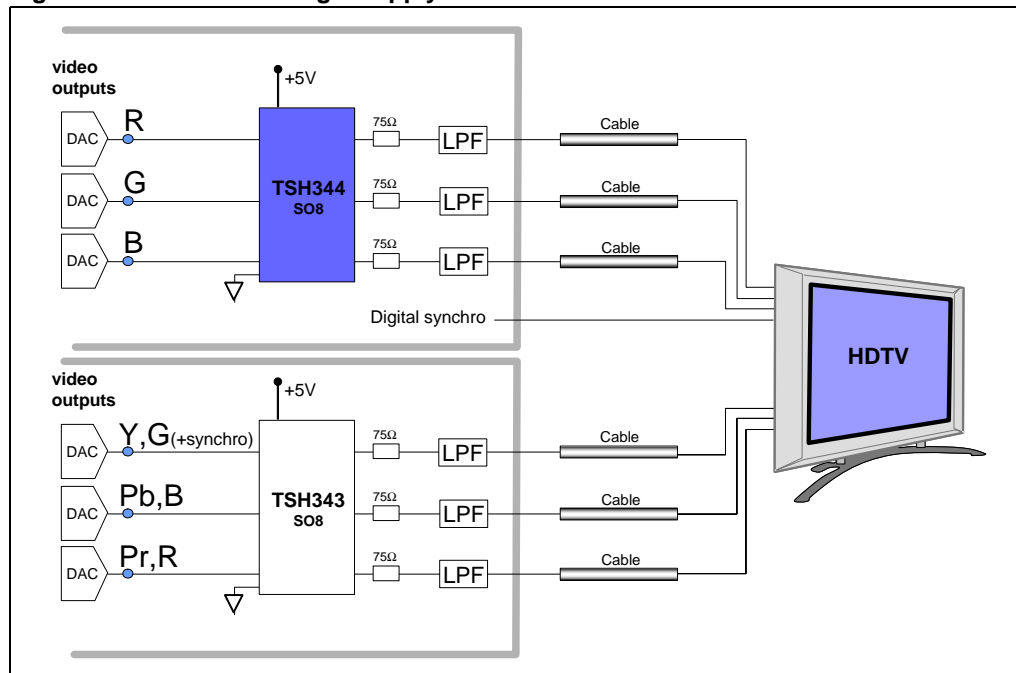
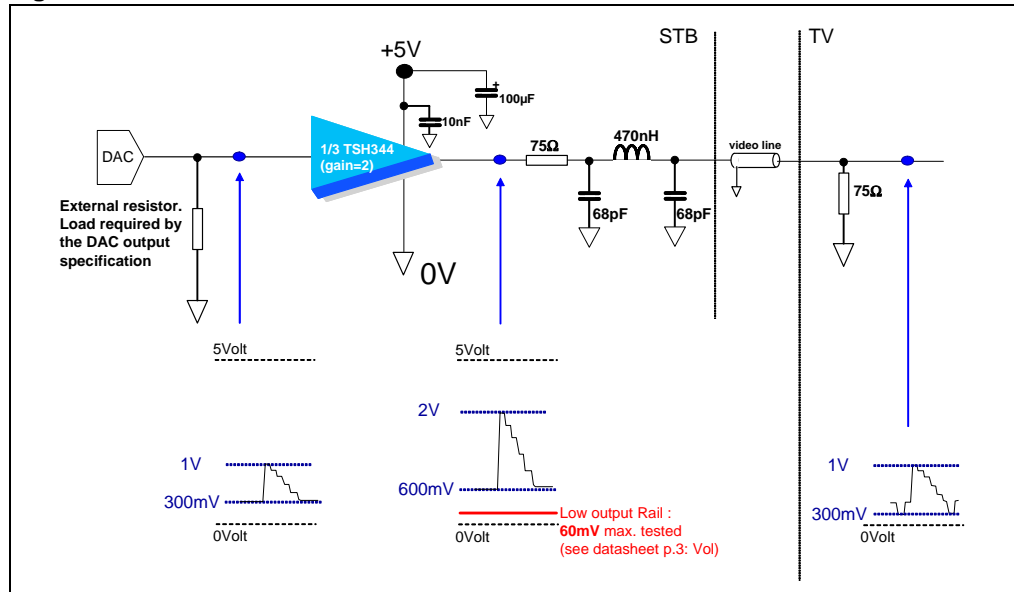

Figure 26. TSH344 in single supply for HD



Note: See the TSH343 datasheet on st.com for more information (the TSH343 is used to drive a video signal including a synchronization tip).

Figure 27. Details on one channel of the TSH344



Because of the shape of the signal described in [Figure 25](#), we use a very low output rail triple high-speed buffer. The TSH344 supplied in 5V single power supply features a low output rail of 60mV (guaranteed by test) on 150Ω load. It is dedicated for driving RGB signals without synchronisation (in the case where the synchronization is provided digitally on the digital bus).

The gain of the TSH344 (gain=2) is internal which makes it possible to remove two resistors on the BOM. To avoid any perturbation on matching from the DACs output impedance along a large band of 30MHz in HD, a discrete reconstruction filtering is implemented after the driver. This filter is matched on 75Ω. Note that the TSH344 uses a single supply architecture and it is not AC output coupled (it cannot sink an output current, therefore it is not possible to implement an output series capacitor).

3.2 Power supply considerations

Correct power supply bypassing is very important for optimizing performance in low and high-frequency ranges. Bypass capacitors should be placed as close as possible to the IC pin (pin 4) to improve high-frequency bypassing. A capacitor (C_{LF}) greater than $100\mu\text{F}$ is necessary to improve the PSRR in low frequencies. For better quality bypassing, a capacitor of 470nF (C_{HF}) is also added as close as possible to the IC pin to improve the PSRR in the higher frequencies.

Figure 28. Circuit for power supply bypassing

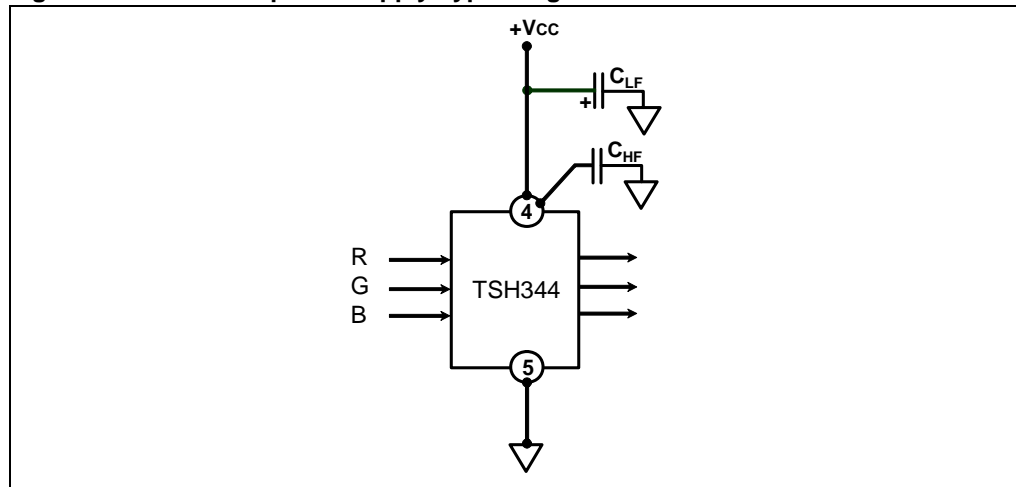
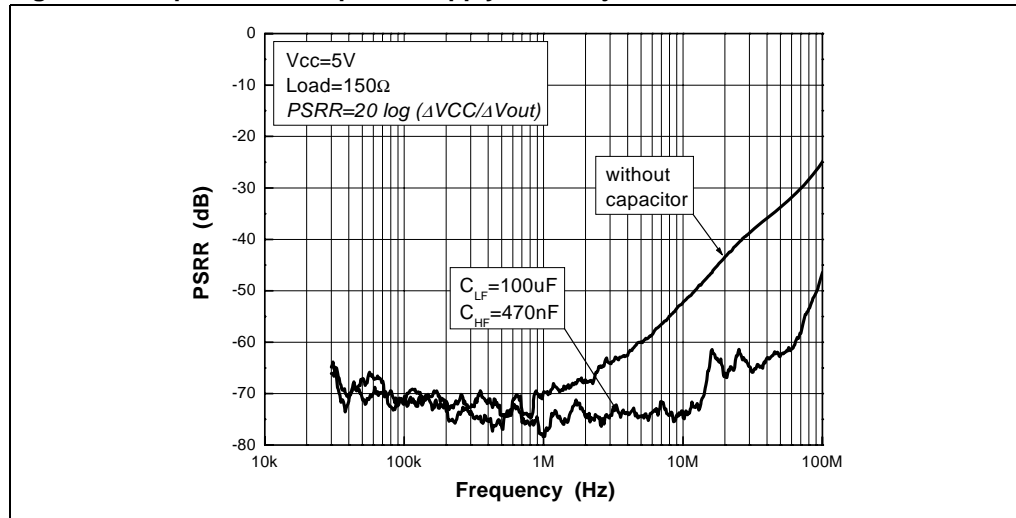

Figure 29 shows how the power supply noise rejection evolves versus frequency depending on how carefully the power supply decoupling is achieved.

Figure 29. Improvement of power supply noise rejection



3.3 Delay between channels

Figure 30. Measurement of the delay between each channel

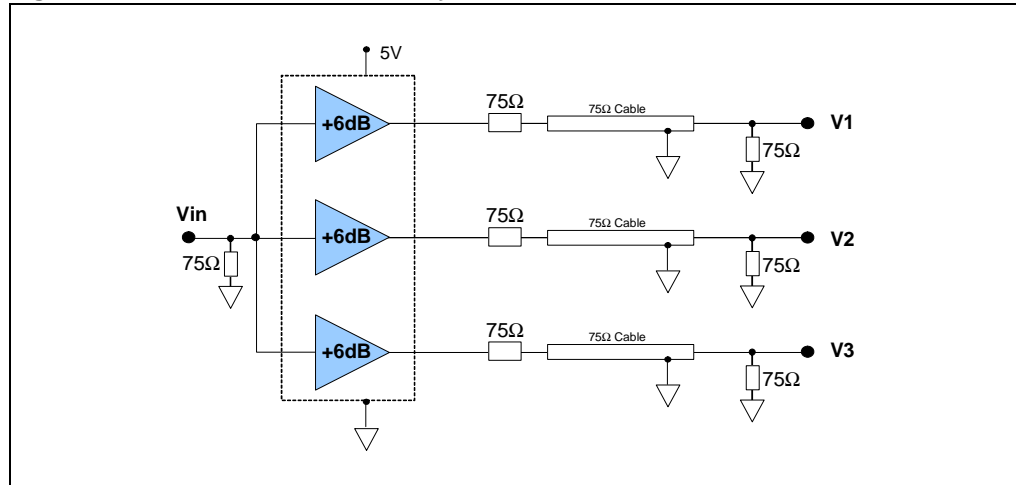

The delay between each video component is an important aspect in high definition video systems. To properly drive the three video components without any relative delay, the layout of the TSH344 dice has a very symmetrical geometry. This has a direct effect on the synchronization of each channel, as shown in [Figure 31](#). There is no delay detected between channels when the same V_{in} signal is applied on the three inputs. Note that the delay between the inputs and the outputs is equal to 4ns .

Figure 31. Relative delay between each channel

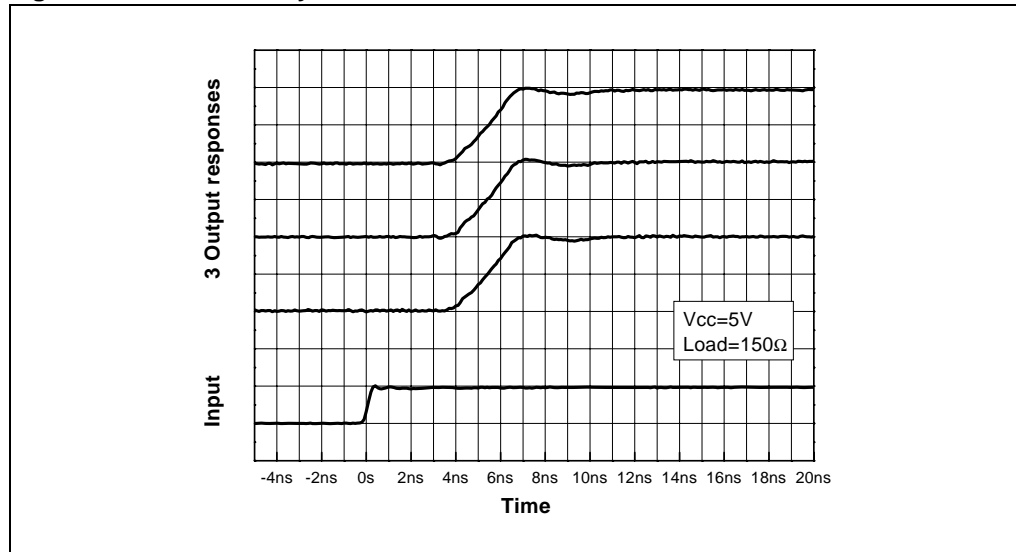

4 Package information

In order to meet environmental requirements, STMicroelectronics offers these devices in ECOPACK[®] packages. These packages have a lead-free second level interconnect. The category of second level interconnect is marked on the package and on the inner box label, in compliance with JEDEC Standard JESD97. The maximum ratings related to soldering conditions are also marked on the inner box label. ECOPACK is an STMicroelectronics trademark. ECOPACK specifications are available at: www.st.com.

Figure 32. SO-8 package mechanical data

Ref.	Dimensions					
	Millimeters			Inches		
	Min.	Typ.	Max.	Min.	Typ.	Max.
A			1.75			0.069
A1	0.10		0.25	0.004		0.010
A2	1.25			0.049		
b	0.28		0.48	0.011		0.019
c	0.17		0.23	0.007		0.010
D	4.80	4.90	5.00	0.189	0.193	0.197
E	5.80	6.00	6.20	0.228	0.236	0.244
E1	3.80	3.90	4.00	0.150	0.154	0.157
e		1.27			0.050	
h	0.25		0.50	0.010		0.020
L	0.40		1.27	0.016		0.050
k	1°		8°	1°		8°
ccc			0.10			0.004

5 Ordering information

Table 4. Order codes

Part number	Temperature range	Package	Packing	Marking
TSH344ID	-40°C to +85°C	SO-8	Tube	TSH344I
TSH344IDT			Tape & reel	TSH344I

6 Revision history

Date	Revision	Changes
Dec-2005	1	First release of datasheet.
Jan-2006	2	Capa-load option paragraph deleted on page 11.
Jul-2006	3	Application information.
14-Mar-2007	4	Updated Section 3.2: Power supply considerations on page 12.

Please Read Carefully:

Information in this document is provided solely in connection with ST products. STMicroelectronics NV and its subsidiaries ("ST") reserve the right to make changes, corrections, modifications or improvements, to this document, and the products and services described herein at any time, without notice.

All ST products are sold pursuant to ST's terms and conditions of sale.

Purchasers are solely responsible for the choice, selection and use of the ST products and services described herein, and ST assumes no liability whatsoever relating to the choice, selection or use of the ST products and services described herein.

No license, express or implied, by estoppel or otherwise, to any intellectual property rights is granted under this document. If any part of this document refers to any third party products or services it shall not be deemed a license grant by ST for the use of such third party products or services, or any intellectual property contained therein or considered as a warranty covering the use in any manner whatsoever of such third party products or services or any intellectual property contained therein.

UNLESS OTHERWISE SET FORTH IN ST'S TERMS AND CONDITIONS OF SALE ST DISCLAIMS ANY EXPRESS OR IMPLIED WARRANTY WITH RESPECT TO THE USE AND/OR SALE OF ST PRODUCTS INCLUDING WITHOUT LIMITATION IMPLIED WARRANTIES OF MERCHANTABILITY, FITNESS FOR A PARTICULAR PURPOSE (AND THEIR EQUIVALENTS UNDER THE LAWS OF ANY JURISDICTION), OR INFRINGEMENT OF ANY PATENT, COPYRIGHT OR OTHER INTELLECTUAL PROPERTY RIGHT.

UNLESS EXPRESSLY APPROVED IN WRITING BY AN AUTHORIZED ST REPRESENTATIVE, ST PRODUCTS ARE NOT RECOMMENDED, AUTHORIZED OR WARRANTED FOR USE IN MILITARY, AIR CRAFT, SPACE, LIFE SAVING, OR LIFE SUSTAINING APPLICATIONS, NOR IN PRODUCTS OR SYSTEMS WHERE FAILURE OR MALFUNCTION MAY RESULT IN PERSONAL INJURY, DEATH, OR SEVERE PROPERTY OR ENVIRONMENTAL DAMAGE. ST PRODUCTS WHICH ARE NOT SPECIFIED AS "AUTOMOTIVE GRADE" MAY ONLY BE USED IN AUTOMOTIVE APPLICATIONS AT USER'S OWN RISK.

Resale of ST products with provisions different from the statements and/or technical features set forth in this document shall immediately void any warranty granted by ST for the ST product or service described herein and shall not create or extend in any manner whatsoever, any liability of ST.

ST and the ST logo are trademarks or registered trademarks of ST in various countries.

Information in this document supersedes and replaces all information previously supplied.

The ST logo is a registered trademark of STMicroelectronics. All other names are the property of their respective owners.

© 2007 STMicroelectronics - All rights reserved

STMicroelectronics group of companies

Australia - Belgium - Brazil - Canada - China - Czech Republic - Finland - France - Germany - Hong Kong - India - Israel - Italy - Japan - Malaysia - Malta - Morocco - Singapore - Spain - Sweden - Switzerland - United Kingdom - United States of America

www.st.com

