

## Triple video buffer with filter for SD video

### Features

- 4.5V to 5.5V single supply operation
- R-G-B, Y-Pb-Pr, Y-C-CvBS driving
- 3 channels with 6dB gain buffer
- 3 video reconstruction filters for SD
- 3 internal input DC level shifter
- No input capacitor is required
- Very low harmonic distortion
- Each output can drive AC- or DC-coupled 150Ω loads
- Tested on 5V power supply
- Data min. and max. are tested during production

### Applications

- Set top boxes
- DVD players/recorders
- High-end video systems
- Standard definition TV (SD)
- Multimedia products

### Description

The TSH173 is a single supply triple video buffer featuring an internal gain of 6dB and an internal low pass filter of 8.2MHz cut-off frequency for each channel to fit with Standard Definition requirements for video line interfaces.

Another advantage of the TSH173 is its input DC level shifter to drive the video signal on a 75Ω video line without any damage to the synchronization tip, while using a single 5V power supply with no input capacitor. The DC level shifter is internally fixed and optimized to keep the output video signal between low and high output rails in the best position to improve linearity.

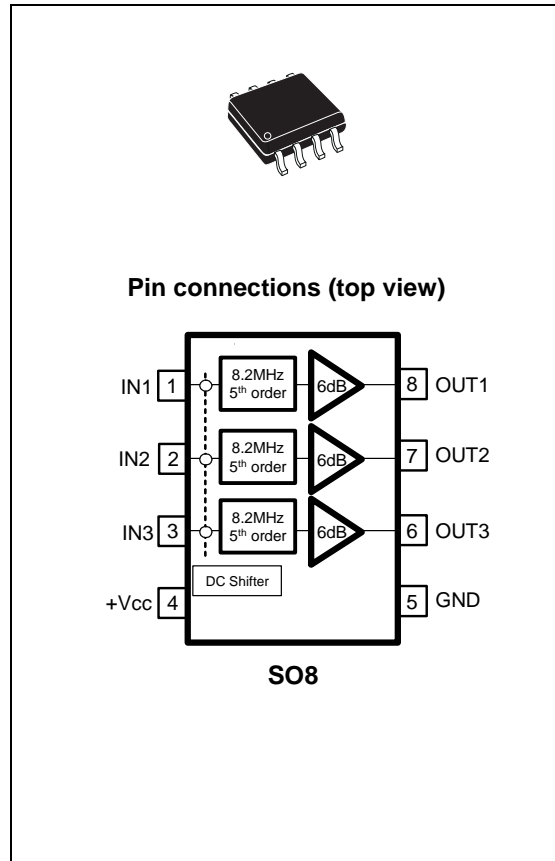

This datasheet gives technical information on using the TSH173 as a R-G-B, Y-Pb-Pr, or Y-C-CvBS driver for video DAC outputs on a video line.

The TSH173 is available in SO8 plastic package.

---

# Contents

<b>1</b>	<b>Absolute maximum ratings</b> .....	<b>3</b>
<b>2</b>	<b>Operating conditions</b> .....	<b>3</b>
<b>3</b>	<b>Electrical characteristics</b> .....	<b>4</b>
	3.1 Synchronization tip .....	8
	3.2 Power supply considerations .....	9
<b>4</b>	<b>Using the TSH173 to drive video components</b> .....	<b>10</b>
<b>5</b>	<b>Package mechanical data</b> .....	<b>11</b>
<b>6</b>	<b>Ordering information</b> .....	<b>12</b>
<b>7</b>	<b>Revision history</b> .....	<b>12</b>

# 1 Absolute maximum ratings

**Table 1. Absolute maximum ratings**

Symbol	Parameter	Value	Unit
$V_{CC}$	Supply voltage <sup>(1)</sup>	6	V
$T_{oper}$	Operating free air temperature range	-40 to +85	°C
$T_{stg}$	Storage temperature	-65 to +150	°C
$T_j$	Maximum junction temperature	150	°C
$R_{thjc}$	SO8 thermal resistance junction to case	28	°C/W
$R_{thja}$	SO8 thermal resistance junction to ambient area	157	°C/W
$P_{max.}$	Maximum power dissipation (@ $T_{amb}=25^{\circ}C$ ) for $T_j=150^{\circ}C$	800	mW
ESD	CDM: charged device model	1.5	kV
	HBM: human body model	2	kV
	MM: machine model	200	V
	Output short-circuit	(2)	

1. All voltage values, except differential voltage, are with respect to network terminal.
2. An output current limitation protects the circuit from transient currents. Short-circuits can cause excessive heating. Destructive dissipation can result from short-circuits on amplifiers.

# 2 Operating conditions

**Table 2. Operating conditions**

Symbol	Parameter	Value	Unit
$V_{CC}$	Power supply voltage	4.5 to 5.5 <sup>(1)</sup>	V

1. Tested in full production at 0V/5V single power supply.

### 3 Electrical characteristics

Table 3.  $V_{CC} = +5V$  single supply, load:  $R_L = 150\Omega$ ,  $T_{amb} = 25^\circ C$  (unless otherwise specified)

Symbol	Parameter	Test conditions	Min.	Typ.	Max.	Unit
<b>DC performance</b>						
$V_{DC}$	Output DC shift		0.6	0.9	1.2	V
		$-40^\circ C < T_{amb} < +85^\circ C$		0.95		
$I_{ib}$	Input bias current	$V_{CC}=+5V, V_{icm}=100mV$		3	6	$\mu A$
		$-40^\circ C < T_{amb} < +85^\circ C$		5		
PSRR	Power supply rejection ratio $20 \log (\Delta V_{cc} / \Delta V_{out})$	$V_{CC}=+5V,$ $\Delta V_{CC}=200mVp-p, F=1MHz$ (without any improvement of the power supply noise rejection)		37		dB
$I_{CC}$	Supply current per channel	$V_{icm}=100mV, \text{ no load}$		7.4	9	mA
		$-40^\circ C < T_{amb} < +85^\circ C$		8		
G	DC voltage gain		1.95	2	2.05	V/V
		$-40^\circ C < T_{amb} < +85^\circ C$		1.95		
GM	Gain matching			0.5	2	%
$V_{OH}$	High level output voltage		3.3	3.8		V
$V_{OL}$	Low level output voltage			210		mV
$I_{OUT}$	$I_{sink}$	$V_{in}=0.5V \text{ DC}$ $V_{out}$ is fixed by a generator at 2.5V	25	34		mA
	$I_{source}$	$V_{in}=0.5V \text{ DC}$ $V_{out}$ is fixed by a generator at 1V	-28	-38		
<b>Dynamic performance (5th order filter)</b>						
$F_{C-SD}$	-3dB bandwidth	Small signal		8.2		MHz
	-1dB bandwidth	Small signal Large signal ( $V_{out}=2Vp-p$ )	5.5 5	6.5 6.3		
$F_{att}$	Filter attenuation	Small signal, $F=27MHz$	40	50		dB
Flatness	Gain flatness along a 4.5MHz band	10kHz to 4.5MHz $V_{out}=2Vp-p$		+/-0.1		dB
gd	Group delay	0 to 6MHz		17		ns
D	Delay between each channel	0 to 6MHz		0.5		ns
dG	Differential gain			0.6		%
dPh	Differential phase			0.15		°
<b>Noise</b>						
SNR	Signal-to-noise ratio	Bw = 10kHz to 6MHz		62		dB

Figure 1. Frequency response

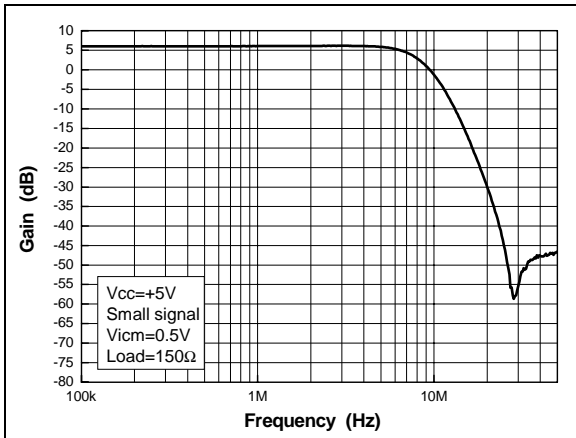

Figure 2. Gain flatness

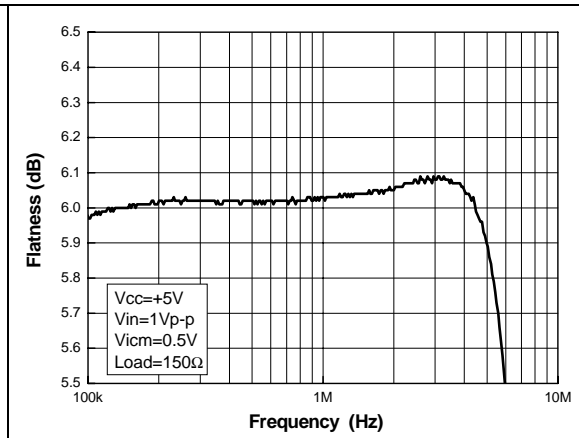

Figure 3. Total input noise vs. frequency

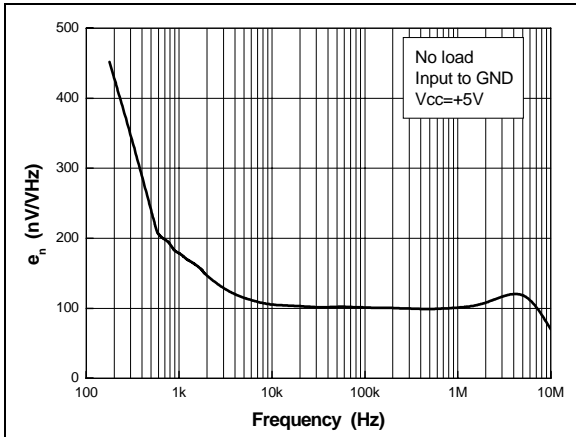

Figure 4. Distortion on 150Ω load

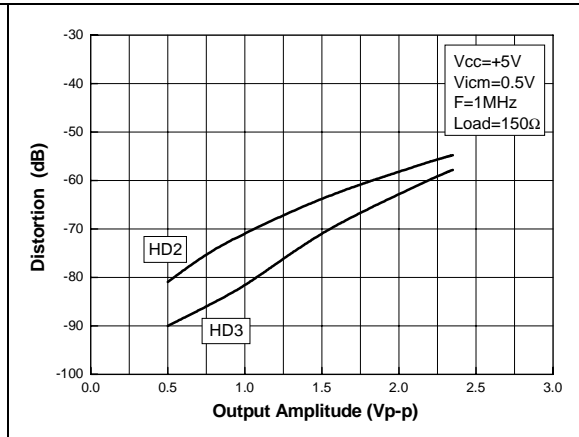

Figure 5. Cross-talk vs. frequency

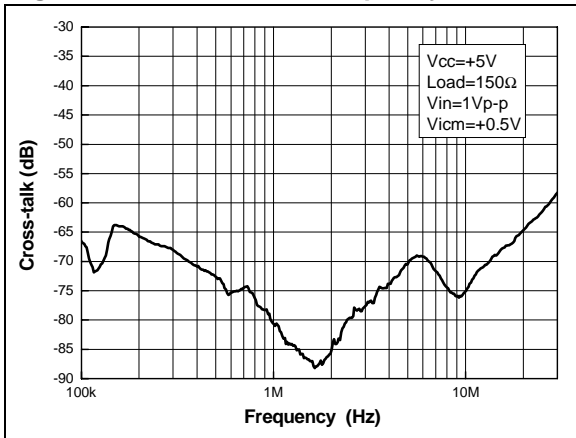

Figure 6. Output voltage swing vs. supply

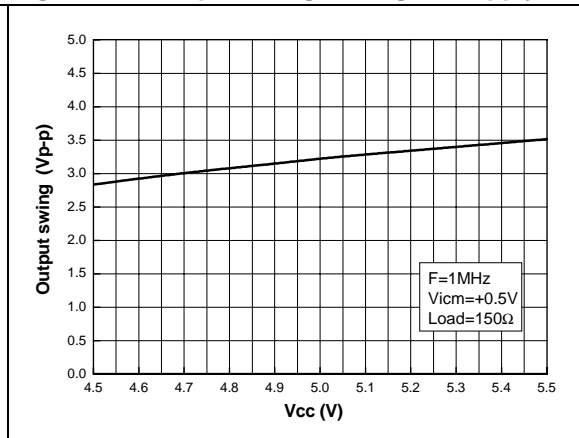

Figure 7. Quiescent current vs. supply

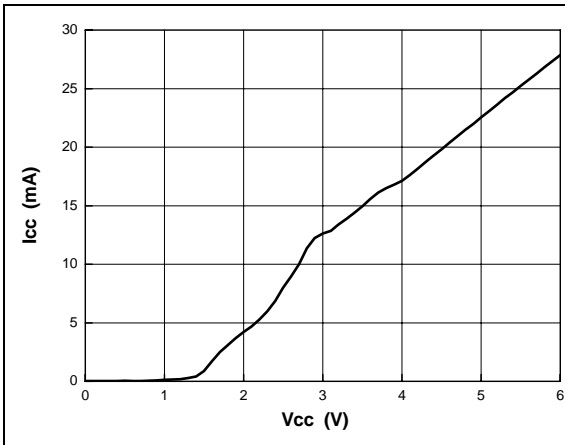

Figure 8.  $I_{sink}$  and  $I_{source}$

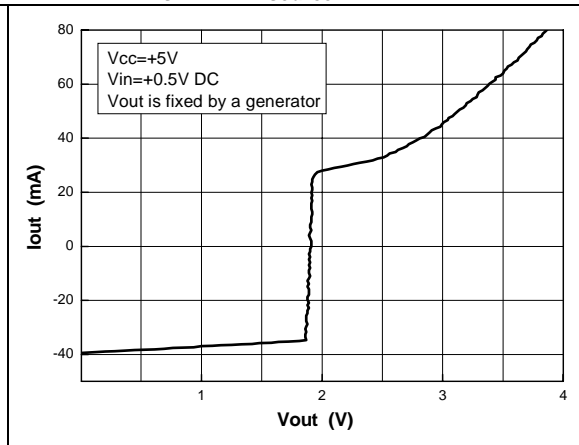

Figure 9. Supply current vs.  $T_{amb}$

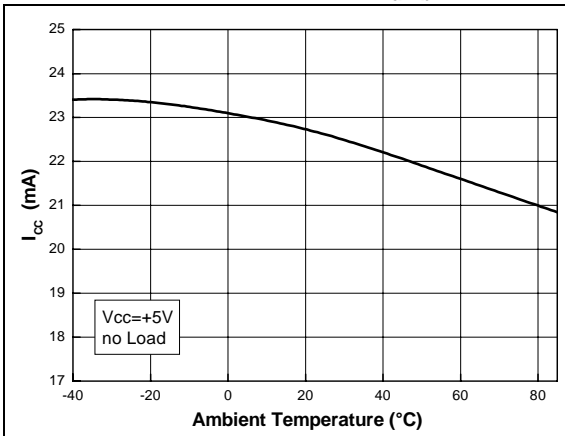

Figure 10. Output DC shift vs.  $T_{amb}$

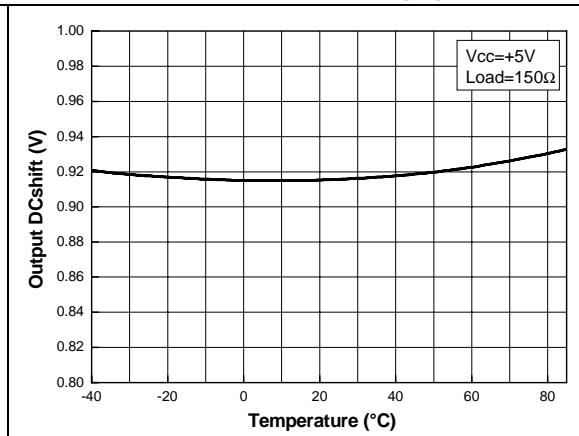

Figure 11. Voltage gain vs.  $T_{amb}$

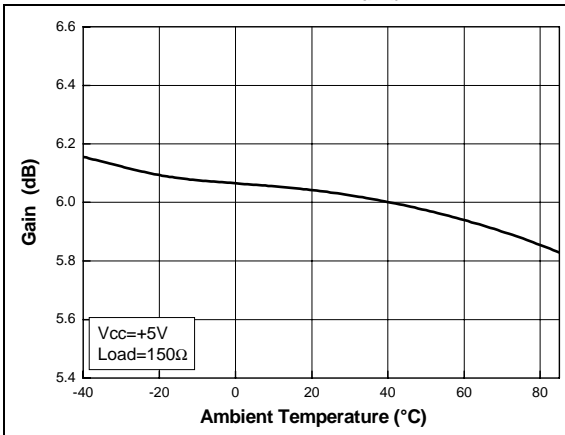

Figure 12. -1dB bandwidth vs.  $T_{amb}$

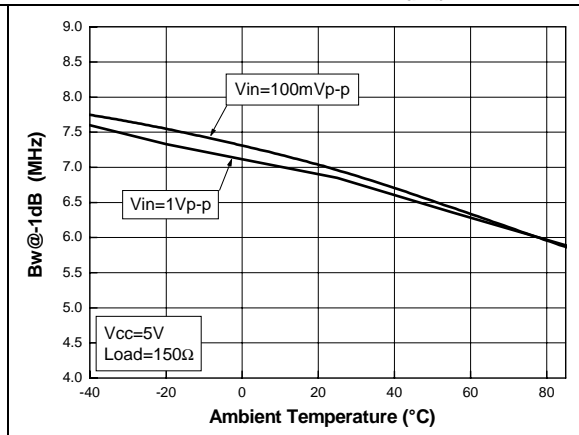

Figure 13. Higher output rail vs.  $T_{amb}$

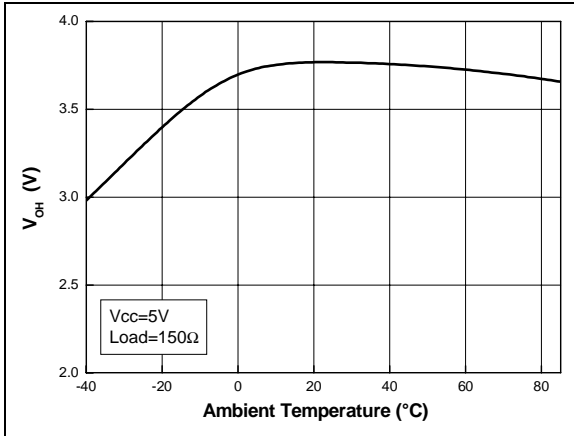

Figure 14. Gain matching vs.  $T_{amb}$

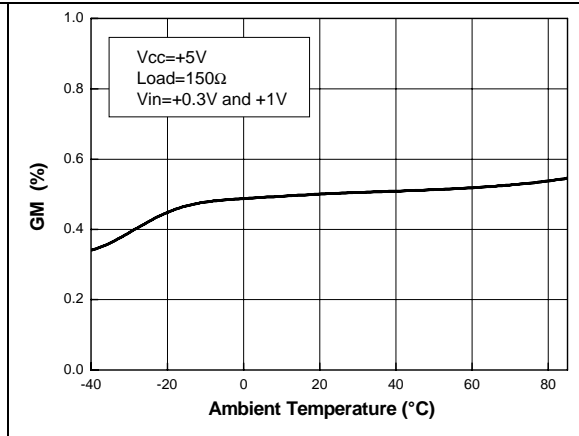

Figure 15.  $I_{sink}$  vs.  $T_{amb}$

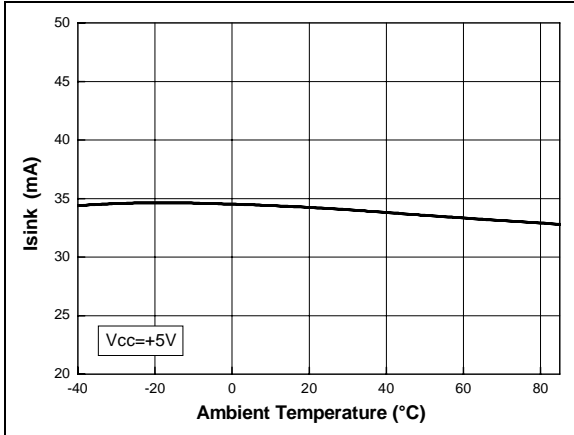

Figure 16.  $I_{source}$  vs.  $T_{amb}$

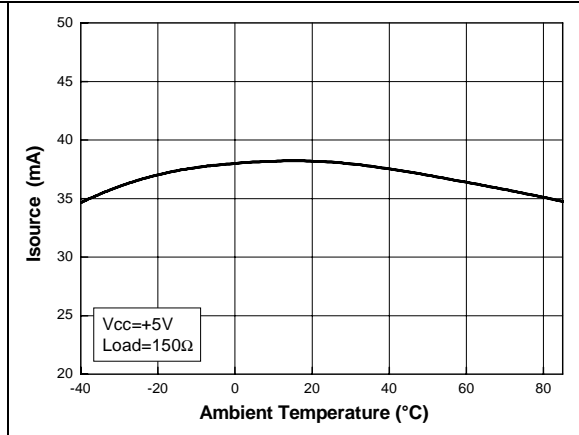
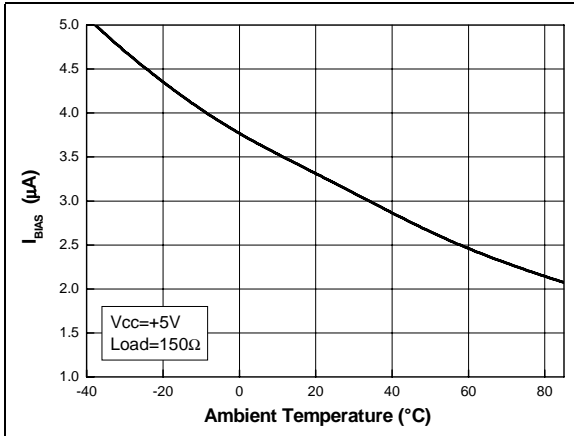

Figure 17.  $I_{bias}$  vs.  $T_{amb}$



### 3.1 Synchronization tip

The TSH173, in single 0/5V supply, is designed to drive the video signal on the line without any damage to the synchronization tip. This is achieved by a small internal DC shift and a very low output rail. The DAC offset, as shown in *Figure 18*, can be as low as 0V. Nevertheless, in order to minimize the DC component on the line, the output can be AC coupled by a capacitor (*Figure 20*).

**Figure 18. Input signal**

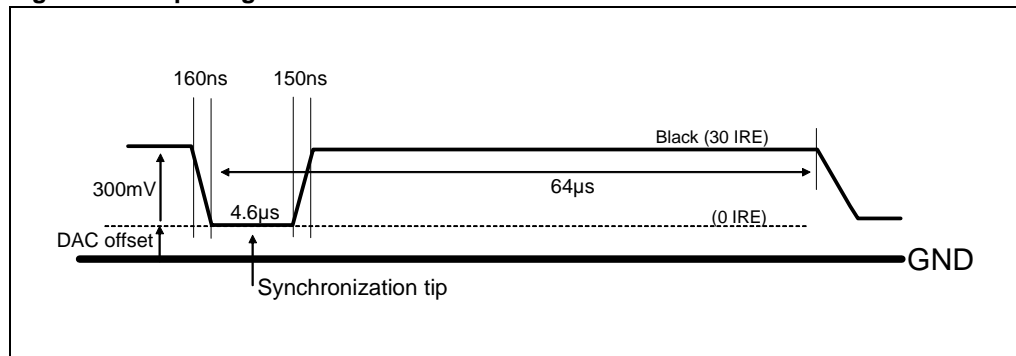

**Figure 19. DC coupled output configuration**

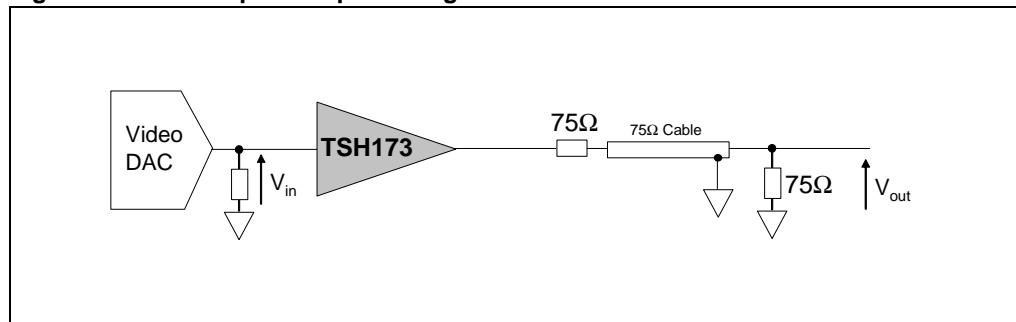

**Figure 20. AC coupled output configuration**

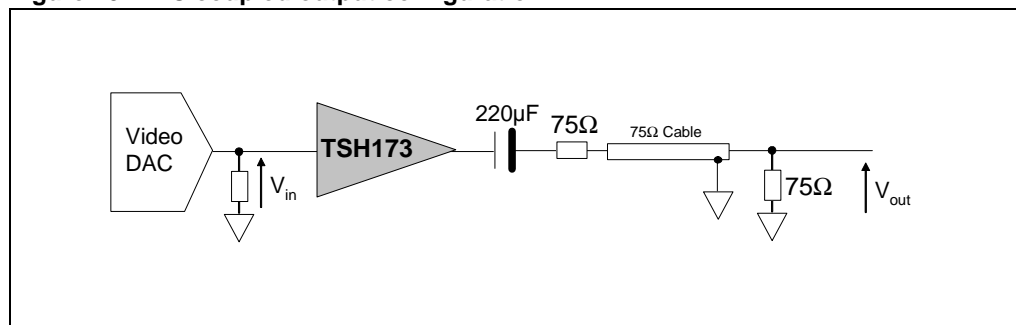



## 3.2 Power supply considerations

Correct power supply bypassing is very important for optimizing performance in high-frequency ranges. Bypass capacitors should be placed as close as possible to the IC pins to improve high-frequency bypassing. A capacitor greater than  $10\mu\text{F}$  is necessary to minimize the distortion. For better quality bypassing, we recommend to add a  $10\text{nF}$  capacitor, also placed as close as possible to the IC pins. Bypass capacitors must be incorporated for both the negative and the positive supply.

**Figure 21. Circuit for power supply bypassing**

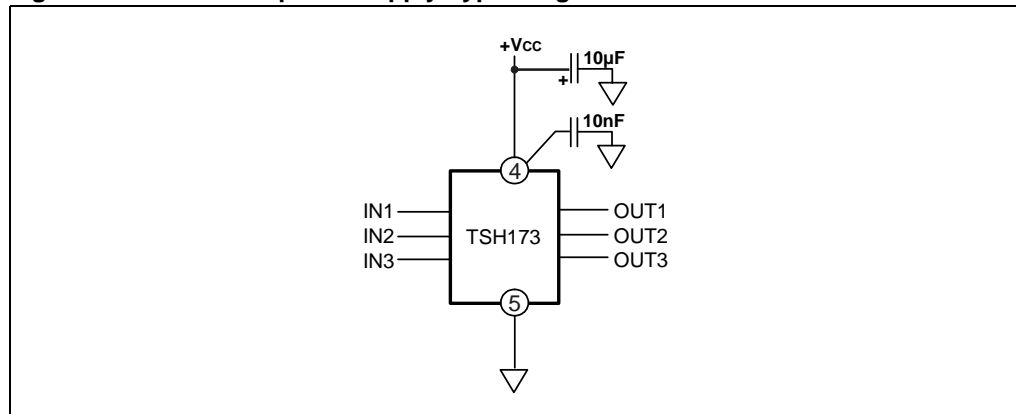

## 4 Using the TSH173 to drive video components

Figure 22. Video line interface implementation schematics

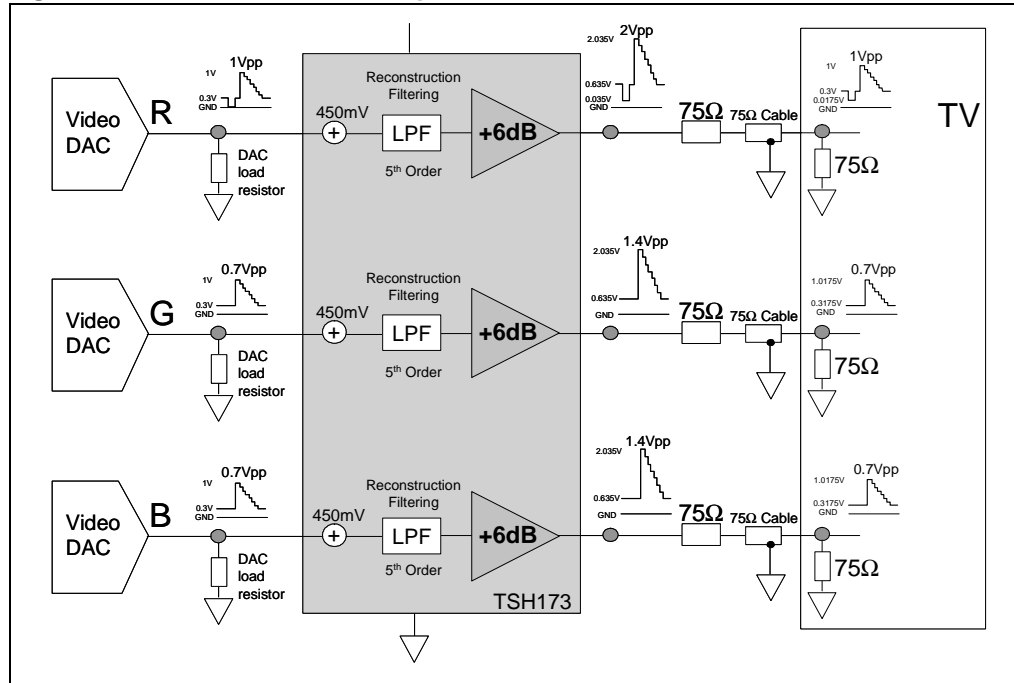

The interface is illustrated in Figure 23. It is composed of:

- Three 75-ohm resistors
- Three matching resistors
- One 10 $\mu$ F power supply decoupling capacitor
- One 10nF power supply decoupling capacitor

Figure 23. Bill of materials of the interface

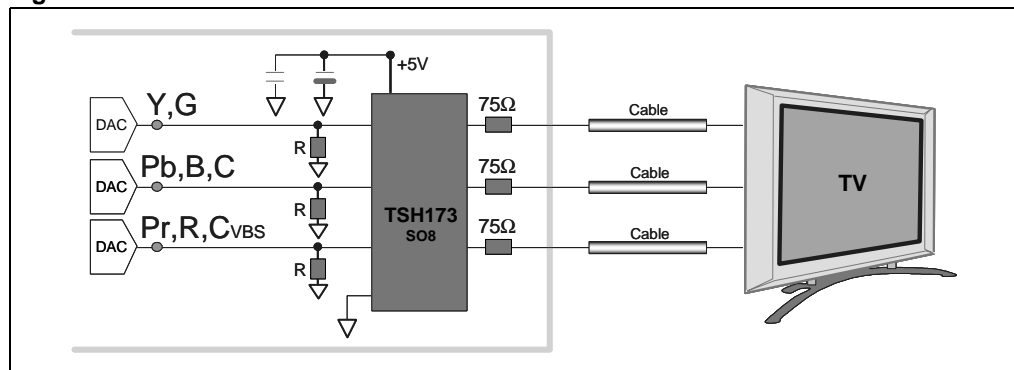

## 5 Package mechanical data

Figure 24. SO-8 package

Ref.	Dimensions					
	Millimeters			Inches		
	Min.	Typ.	Max.	Min.	Typ.	Max.
A	1.35		1.75	0.053		0.069
A1	0.10		0.25	0.04		0.010
A2	1.10		1.65	0.043		0.065
B	0.33		0.51	0.013		0.020
C	0.19		0.25	0.007		0.010
D	4.80		5.00	0.189		0.197
E	3.80		4.00	0.150		0.157
e		1.27			0.050	
H	5.80		6.20	0.228		0.244
h	0.25		0.50	0.010		0.020
L	0.40		1.27	0.016		0.050
k	8° (max.)					
ddd			0.1			0.04

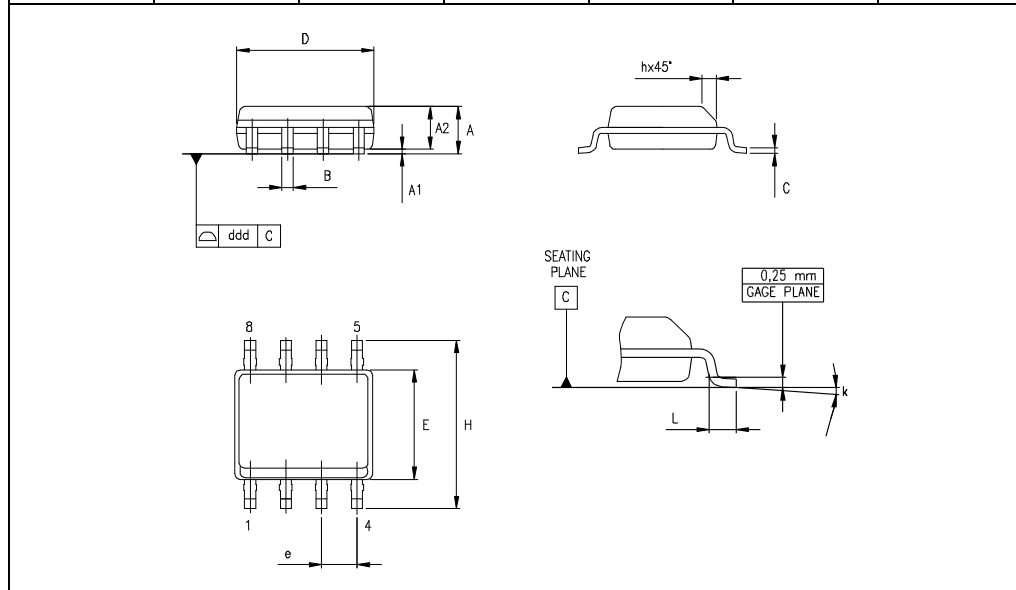

## 6 Ordering information

Table 4. Order codes

Part number	Temperature range	Package	Packaging	Marking
TSH173ID	-40°C to +85°C	SO-8	Tube	TSH173I
TSH173IDT		SO-8	Tape & reel	TSH173I

## 7 Revision history

Date	Revision	Changes
21-Mar-2007	1	Initial release.

**Please Read Carefully:**

Information in this document is provided solely in connection with ST products. STMicroelectronics NV and its subsidiaries ("ST") reserve the right to make changes, corrections, modifications or improvements, to this document, and the products and services described herein at any time, without notice.

All ST products are sold pursuant to ST's terms and conditions of sale.

Purchasers are solely responsible for the choice, selection and use of the ST products and services described herein, and ST assumes no liability whatsoever relating to the choice, selection or use of the ST products and services described herein.

No license, express or implied, by estoppel or otherwise, to any intellectual property rights is granted under this document. If any part of this document refers to any third party products or services it shall not be deemed a license grant by ST for the use of such third party products or services, or any intellectual property contained therein or considered as a warranty covering the use in any manner whatsoever of such third party products or services or any intellectual property contained therein.

**UNLESS OTHERWISE SET FORTH IN ST'S TERMS AND CONDITIONS OF SALE ST DISCLAIMS ANY EXPRESS OR IMPLIED WARRANTY WITH RESPECT TO THE USE AND/OR SALE OF ST PRODUCTS INCLUDING WITHOUT LIMITATION IMPLIED WARRANTIES OF MERCHANTABILITY, FITNESS FOR A PARTICULAR PURPOSE (AND THEIR EQUIVALENTS UNDER THE LAWS OF ANY JURISDICTION), OR INFRINGEMENT OF ANY PATENT, COPYRIGHT OR OTHER INTELLECTUAL PROPERTY RIGHT.**

**UNLESS EXPRESSLY APPROVED IN WRITING BY AN AUTHORIZED ST REPRESENTATIVE, ST PRODUCTS ARE NOT RECOMMENDED, AUTHORIZED OR WARRANTED FOR USE IN MILITARY, AIR CRAFT, SPACE, LIFE SAVING, OR LIFE SUSTAINING APPLICATIONS, NOR IN PRODUCTS OR SYSTEMS WHERE FAILURE OR MALFUNCTION MAY RESULT IN PERSONAL INJURY, DEATH, OR SEVERE PROPERTY OR ENVIRONMENTAL DAMAGE. ST PRODUCTS WHICH ARE NOT SPECIFIED AS "AUTOMOTIVE GRADE" MAY ONLY BE USED IN AUTOMOTIVE APPLICATIONS AT USER'S OWN RISK.**

Resale of ST products with provisions different from the statements and/or technical features set forth in this document shall immediately void any warranty granted by ST for the ST product or service described herein and shall not create or extend in any manner whatsoever, any liability of ST.

ST and the ST logo are trademarks or registered trademarks of ST in various countries.

Information in this document supersedes and replaces all information previously supplied.

The ST logo is a registered trademark of STMicroelectronics. All other names are the property of their respective owners.

© 2007 STMicroelectronics - All rights reserved

STMicroelectronics group of companies

Australia - Belgium - Brazil - Canada - China - Czech Republic - Finland - France - Germany - Hong Kong - India - Israel - Italy - Japan - Malaysia - Malta - Morocco - Singapore - Spain - Sweden - Switzerland - United Kingdom - United States of America

[www.st.com](http://www.st.com)

