



TSH94

High speed low power quad operational amplifier with standby position

Features

- Two separate standby functions: low consumption and high impedance outputs
- Low supply current: 4.5 mA
- High speed: 150 MHz - 110 V/ μ s
- Unity gain stability
- Low offset voltage: 3 mV
- Low noise 4.2 nV/ \sqrt Hz
- Low cost
- Specified for 600 Ω and 150 Ω loads
- High video performance:
 - Differential gain: 0.03%
 - Differential phase: 0.07°
 - Gain flatness: 6 MHz, 0.1 dB max at 10 dB gain
- High audio performance

Applications

- Set-top-boxes
- TV
- DVD players

Description

The TSH94 is a quad low-power high-frequency operation amplifier, designed for high-quality video signal processing. The device offers an excellent speed consumption ratio with 4.5 mA per amplifier for a 150 MHz bandwidth.

High slew rate and low noise also make it suitable for high-quality audio applications.

The TSH94 offers two separate complementary STANDBY functions: STANDBY 1 acting on the n° 2 operator and STANDBY 2 acting on the n° 3 operator.

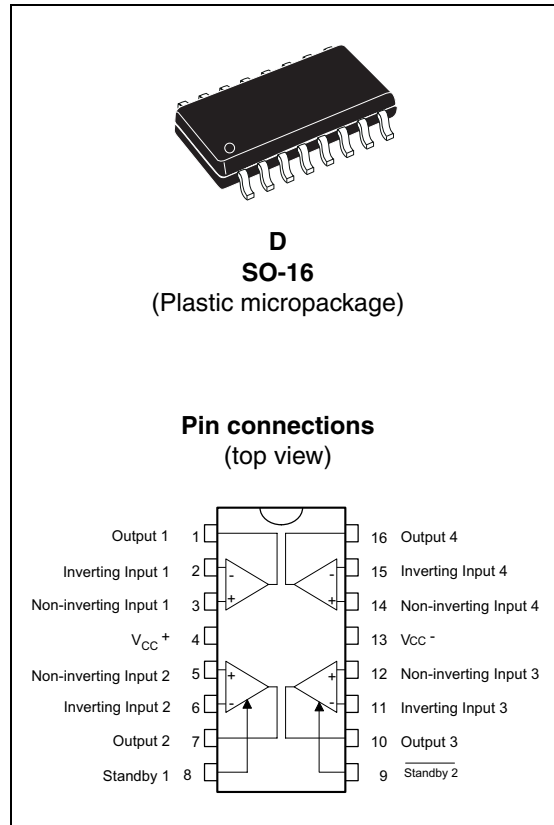

These functions reduce the consumption of the corresponding operator and put the output in a high impedance state.

1 Schematic diagram

Figure 1. Schematic diagram

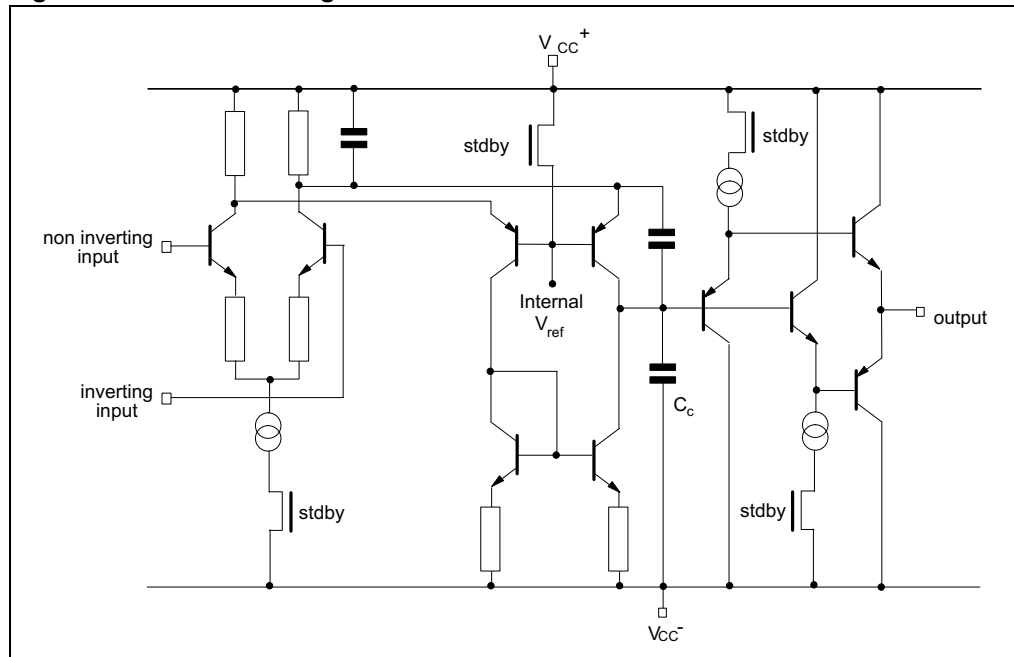

2 Absolute maximum ratings and operating conditions

Table 1. Absolute maximum ratings

Symbol	Parameter	Value	Unit
V_{CC}	Supply voltage ⁽¹⁾	14	V
V_{id}	Differential input voltage ⁽²⁾	±5	V
V_i	Input voltage ⁽³⁾	-0.3 to 12	V
T_{oper}	Operating free-air temperature range	-40 to +125	°C
T_{stg}	Storage temperature range	-65 to +150	°C
ESD	CDM: charged device model ⁽⁴⁾	1.5	kV
	HBM: human body model ⁽⁵⁾	2	kV
	MM: machine model ⁽⁶⁾	200	V

1. All voltage values, except differential voltage are with respect to network ground terminal.
2. Differential voltages are the non-inverting input terminal with respect to the inverting input terminal.
3. The magnitude of input and output voltages must never exceed $V_{CC}^+ + 0.3$ V.
4. Charged device model: all pins and the package are charged together to the specified voltage and then discharged directly to the ground through only one pin. This is done for all pins.
5. Human body model: a 100 pF capacitor is charged to the specified voltage, then discharged through a 1.5 kΩ resistor between two pins of the device. This is done for all couples of connected pin combinations while the other pins are floating.
6. Machine model: a 200 pF capacitor is charged to the specified voltage, then discharged directly between two pins of the device with no external series resistor (internal resistor < 5 Ω). This is done for all couples of connected pin combinations while the other pins are floating

Table 2. Operating conditions

Symbol	Parameter	Value	Unit
V_{CC}	Supply voltage	7 to 12	V
V_{icm}	Common mode input voltage range	$V_{CC}^- + 2$ to $V_{CC}^+ - 1$	V

3 Electrical characteristics

Table 3. $V_{CC}^+ = 5\text{ V}$, $V_{CC}^- = -5\text{ V}$, pin 8 connected to 0 V, pin 9 connected to V_{CC}^+ , $T_{amb} = 25^\circ\text{ C}$
(unless otherwise specified)

Symbol	Parameter	Min.	Typ.	Max.	Unit
V_{io}	Input offset voltage $V_{ic} = V_o = 0\text{ V}$ $T_{min} \leq T_{amb} \leq T_{max}$			3 5	mV
I_{io}	Input offset current $T_{min} \leq T_{amb} \leq T_{max}$		1	2 5	μA
I_{ib}	Input bias current $T_{min} \leq T_{amb} \leq T_{max}$		5	15 20	μA
I_{CC}	Supply current (per amplifier, no load) $T_{min} \leq T_{amb} \leq T_{max}$		4.5	6 8	mA
CMR	Common mode rejection ratio $V_{ic} = -3\text{ V to } +4\text{ V}$, $V_o = 0\text{ V}$ $T_{min} \leq T_{amb} \leq T_{max}$	80 70	100		dB
SVR	Supply voltage rejection ratio $V_{CC} = \pm 5\text{ V to } \pm 3\text{ V}$ $T_{min} \leq T_{amb} \leq T_{max}$	60 50	75		dB
A_{vd}	Large signal voltage gain $R_L = 10\text{ k}\Omega$, $V_o = \pm 2.5\text{ V}$ $T_{min} \leq T_{amb} \leq T_{max}$	57 54	70		dB
V_{OH}	High level output voltage $V_{id} = 1\text{ V}$ $R_L = 600\ \Omega$ $R_L = 150\ \Omega$ $T_{min} \leq T_{amb} \leq T_{max}$, $R_L = 150\ \Omega$	3 2.5 2.4	3.5 3		V
V_{OL}	Low level output voltage $V_{id} = 11\text{ V}$ $R_L = 600\ \Omega$ $R_L = 150\ \Omega$ $T_{min} \leq T_{amb} \leq T_{max}$, $R_L = 150\ \Omega$		-3.5 -2.8	-3 -2.5 -2.4	V
I_o	Output short-circuit current $V_{id} = \pm 1\text{ V}$ Source Sink $T_{min} \leq T_{amb} \leq T_{max}$, Source Sink	20 20 15 15	36 40		mA
GBP	Gain bandwidth product $A_{VCL} = 100$, $R_L = 600\ \Omega$, $C_L = 15\text{ pF}$, $f = 7.5\text{ MHz}$	90	150		MHz
f_T	Transition frequency		90		MHz
SR	Slew rate $V_{in} = -2\text{ to } +2\text{ V}$, $A_{VCL} = +1$, $R_L = 600\ \Omega$, $C_L = 15\text{ pF}$	70	110		V/ μs
e_n	Equivalent input voltage noise $R_s = 50\ \Omega$, $f = 1\text{ kHz}$		4.2		nV/ $\sqrt{\text{Hz}}$
ϕ_m	Phase margin $A_{VM} = +1$		35		Degrees
V_{O1}/V_{O2}	Channel separation $f = 1\text{ MHz to } 10\text{ MHz}$		65		dB
G_f	Gain flatness $f = \text{DC to } 6\text{ MHz}$, $A_{VCL} = 10\text{ dB}$			0.1	dB
THD	Total harmonic distortion $f = 1\text{ kHz}$, $V_o = \pm 2.5\text{ V}$, $R_L = 600\ \Omega$		0.01		%

Table 3. $V_{CC}^+ = 5\text{ V}$, $V_{CC}^- = -5\text{ V}$, pin 8 connected to 0 V, pin 9 connected to V_{CC}^+ , $T_{amb} = 25^\circ\text{ C}$
(unless otherwise specified) (continued)

Symbol	Parameter	Min.	Typ.	Max.	Unit
ΔG	Differential gain $f = 3.58\text{ MHz}$, $A_{VCL} = +2$, $R_L = 150\ \Omega$		0.03		%
$\Delta\varphi$	Differential phase $f = 3.58\text{ MHz}$, $A_{VCL} = +2$, $R_L = 150\ \Omega$		0.07		Degree

Standby mode

Table 4. $V_{CC}^+ = 5\text{ V}$, $V_{CC}^- = -5\text{ V}$, $T_{amb} = 25^\circ\text{ C}$ (unless otherwise specified)

Symbol	Parameter	Min.	Typ.	Max.	Unit
V_{STBY}	Pin 8/9 threshold voltage for STANDBY mode	$V_{CC}^+ - 2.2$	$V_{CC}^+ - 1.6$	$V_{CC}^+ - 1.0$	V
$I_{CC-STBY}$	Total consumption				mA
	Standby 1 & 2 = 0		13.7		
	Standby 1 & 2 = 1		13.7		
	Standby 1 = 1, Standby 2 = 0		9.4		
I_{sol}	Input/output isolation ($f = 1\text{ MHz}$ to 10 MHz)		70		dB
t_{on}	Time from standby mode to active mode		200		ns
t_{off}	Time from active mode to standby mode		200		ns
I_D	Standby driving current		2		pA
I_{OL}	Output leakage current		20		pA
I_{IL}	Input leakage current		20		pA

Table 5. Standby control pin status

Logic input		Status		
Standby 1	Standby 2	Op-amp 2	Op-amp 3	Op-amps 1 & 4
0	0	Enable	Standby	Enable
0	1	Enable	Enable	Enable
1	0	Standby	Standby	Enable
1	1	Standby	Enable	Enable

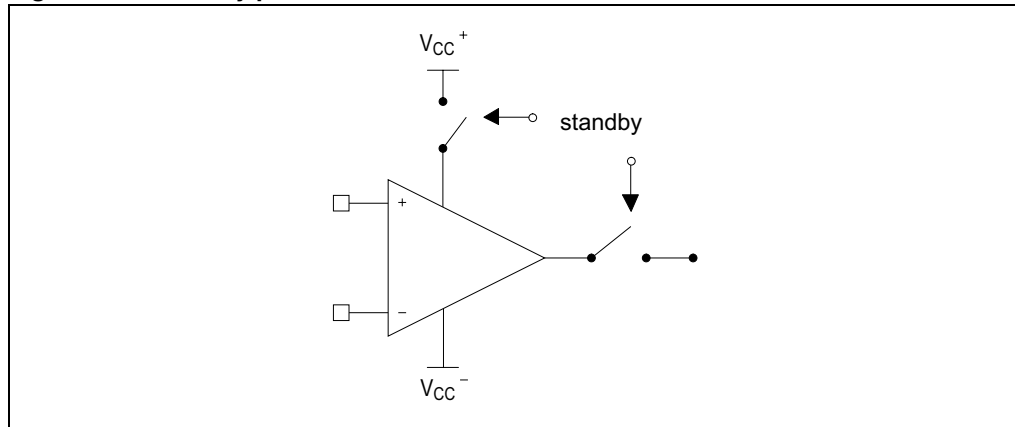
Figure 2. Standby position

To put the device in standby, apply a logic level on the standby MOS input. Because ground is a virtual level for the device, the threshold voltage is to V_{CC}^+ ($V_{CC}^+ - 1.6$ V typ, see [Table 4](#)).

Figure 3. Closed-loop frequency response

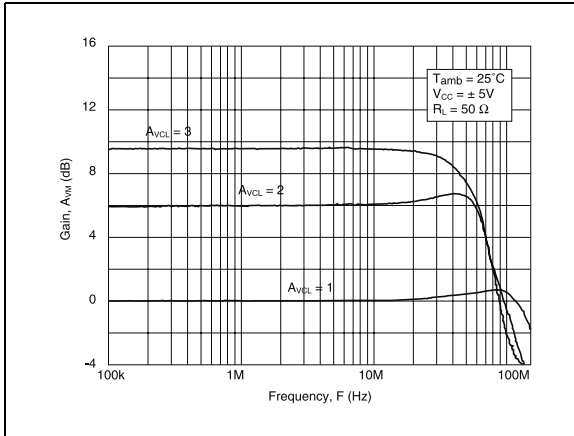

Figure 4. Gain flatness and phase shift versus frequency

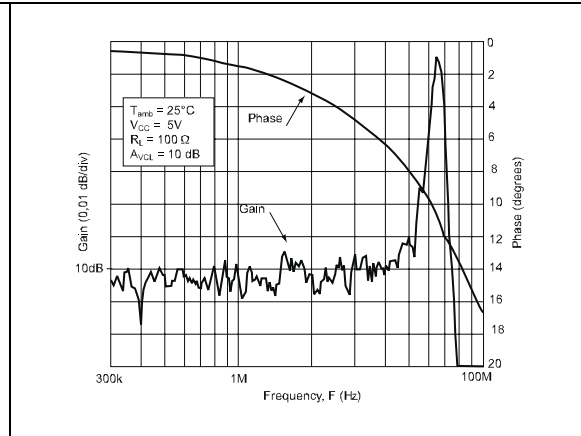

Figure 5. Open-loop frequency response and phase shift

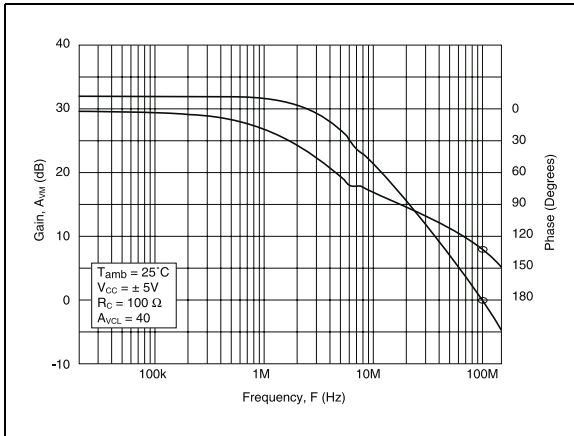

Figure 6. Static open-loop voltage gain

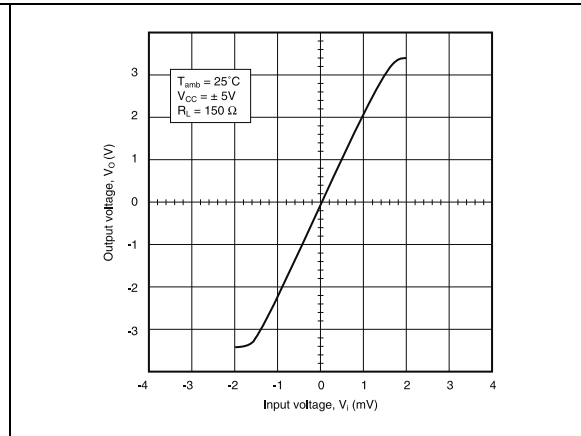

Figure 7. Audio bandwidth frequency response and phase shift (TSH94 vs standard 15 MHz audio op-amp)

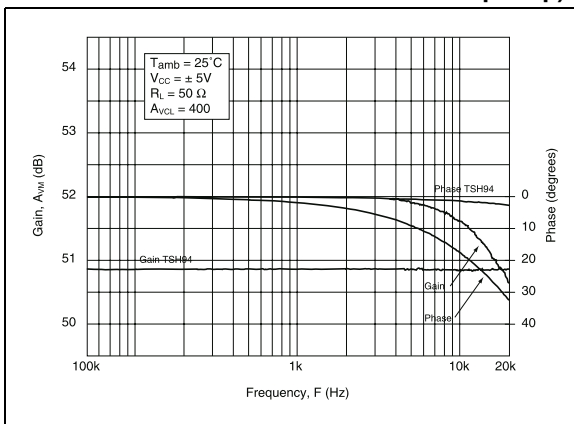

Figure 8. Large signal follower response

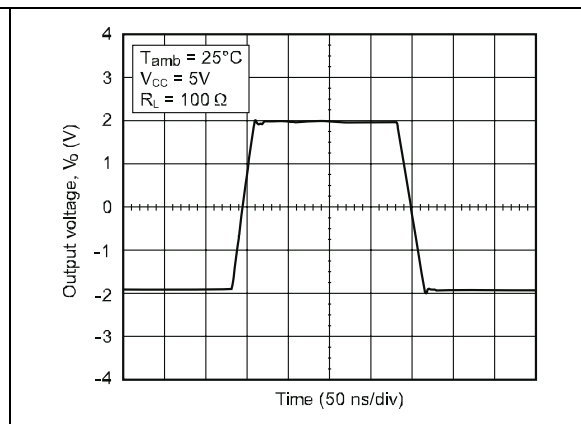

Figure 9. Small signal follower response

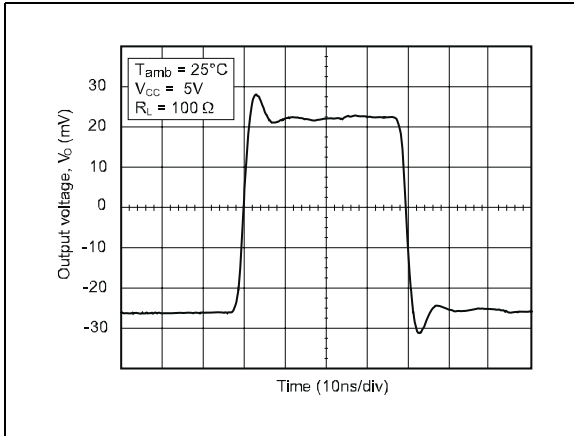

Figure 10. Crosstalk isolation versus frequency (SO-16 package)

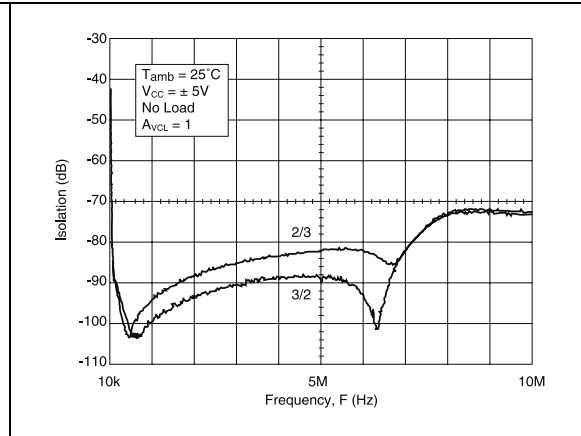

Figure 11. Crosstalk isolation versus frequency (SO-16 package)

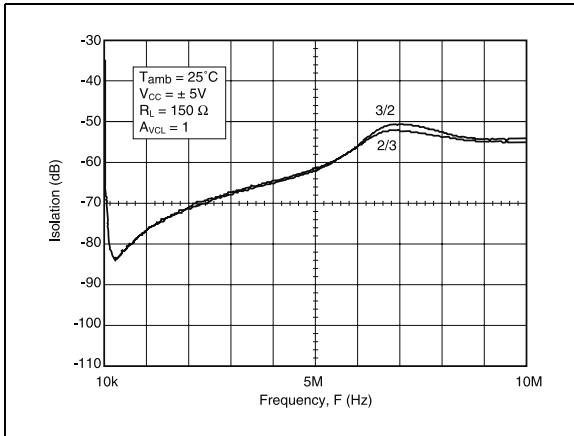

Figure 12. Input/output isolation in standby mode (SO-16 package)

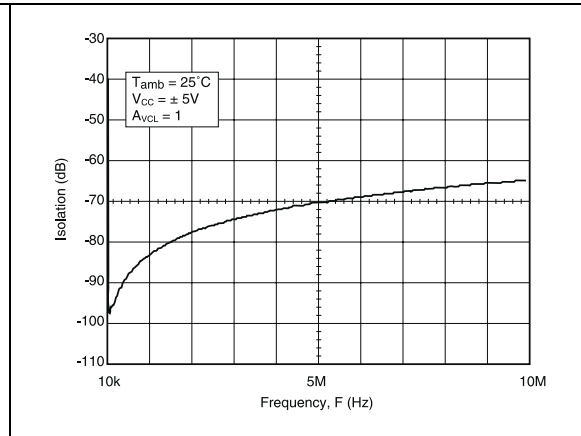

Figure 13. Standby switching

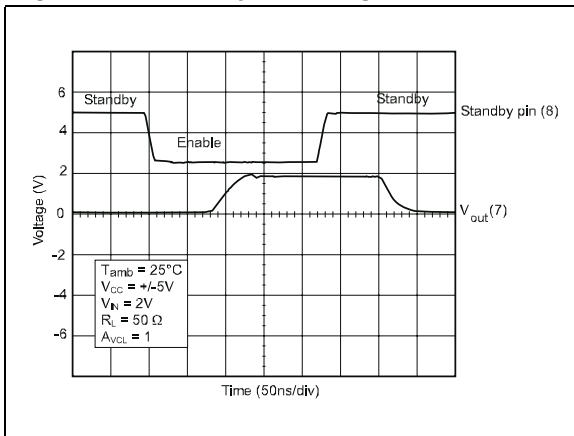

Figure 14. Signal multiplexing (see Figure 18)

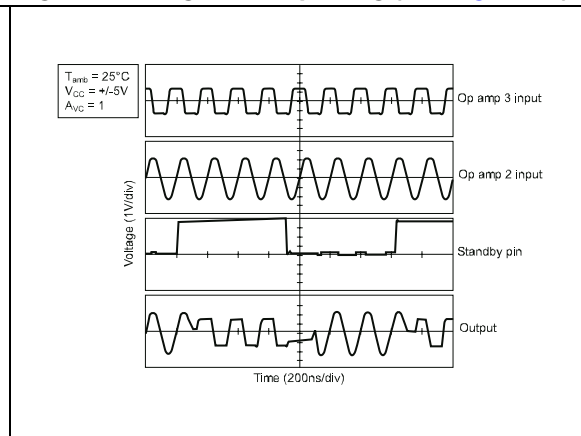

Figure 15. Common input impedance versus frequency

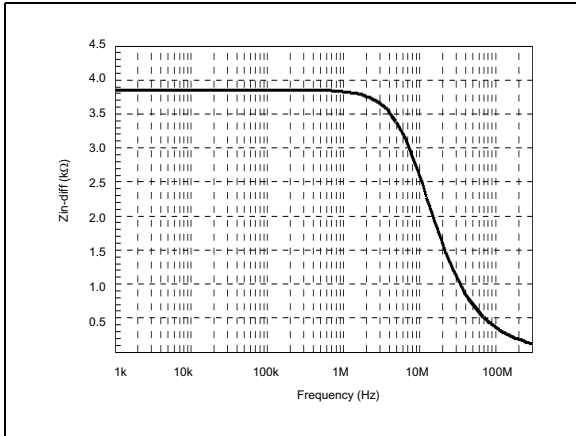

Figure 16. Differential input impedance versus frequency

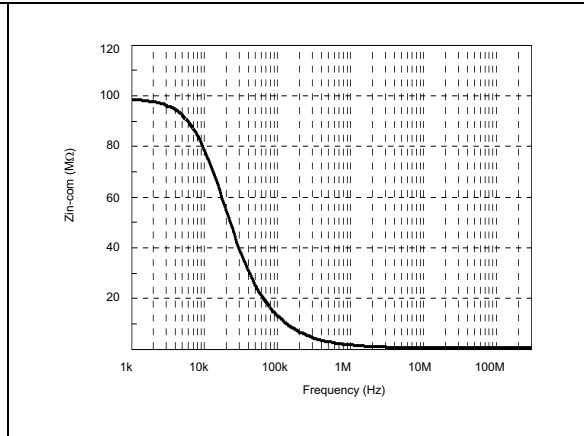
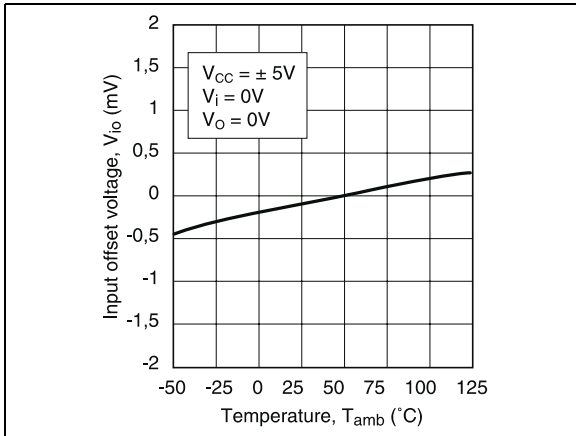

Figure 17. Input offset voltage drift versus temperature



4 Application information

Figure 18. Signal multiplexing

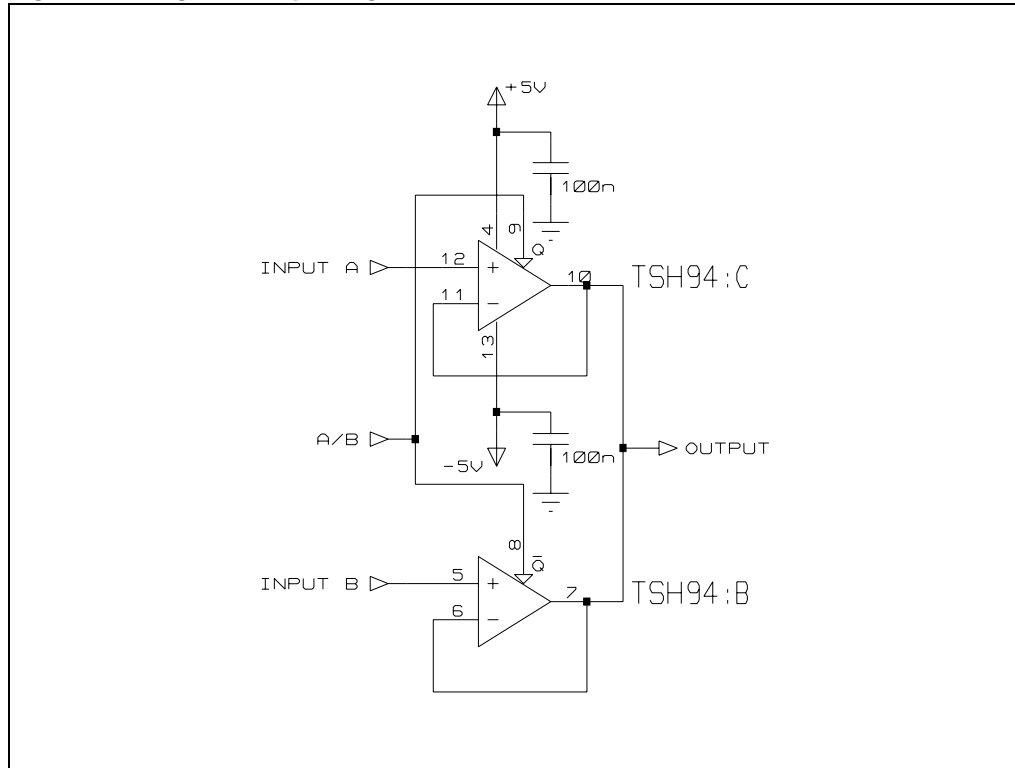
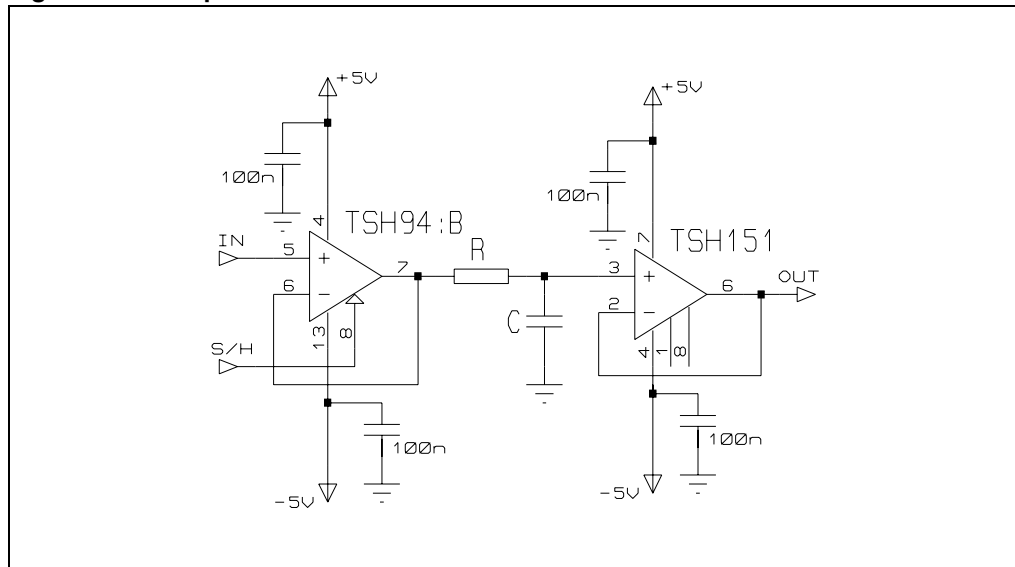

Figure 19. Sample and hold



5 Macromodel information

5.1 TSH94I without standby

The macromodel information provided in this section applies to TSH94I (model without standby).

```

** Standard Linear Ics Macromodels, 1996.
** CONNECTIONS :
* 1 INVERTING INPUT
* 2 NON-INVERTING INPUT
* 3 OUTPUT
* 4 POSITIVE POWER SUPPLY
* 5 NEGATIVE POWER SUPPLY
.SUBCKT TSH94 1 3 2 4 5 (analog)
*****
.MODEL MDTH D IS=1E-8 KF=1.809064E-15
CJO=10F
* INPUT STAGE
CIP 2 5 1.000000E-12
CIN 1 5 1.000000E-12
EIP 10 5 2 5 1
EIN 16 5 1 5 1
RIP 10 11 2.600000E-01
RIN 15 16 2.600000E-01
RIS 11 15 3.645298E-01
DIP 11 12 MDTH 400E-12
DIN 15 14 MDTH 400E-12
VOFP 12 13 DC 0.000000E+00
VOFN 13 14 DC 0
IPOL 13 5 1.000000E-03
CPS 11 15 2.986990E-10
DINN 17 13 MDTH 400E-12
VIN 17 5 2.000000E+00
DINR 15 18 MDTH 400E-12
VIP 4 18 1.000000E+00
FCP 4 5 VOFP 3.500000E+00
FCN 5 4 VOFN 3.500000E+00
FIBP 2 5 VOFP 1.000000E-02
FIBN 5 1 VOFN 1.000000E-02
* AMPLIFYING STAGE
FIP 5 19 VOFP 2.530000E+02
FIN 5 19 VOFN 2.530000E+02
RG1 19 5 3.160721E+03
RG2 19 4 3.160721E+03
CC 19 5 2.000000E-09
DOPM 19 22 MDTH 400E-12
DONM 21 19 MDTH 400E-12
HOPM 22 28 VOUT 1.504000E+03
VIPM 28 4 5.000000E+01
HONM 21 27 VOUT 1.400000E+03

```

```

VINM 5 27 5.000000E+01
*****
RZP1 5 80 1E+06
RZP2 4 80 1E+06
GZP 5 82 19 80 2.5E-05
RZP2H 83 4 10000
RZP1H 83 82 80000
RZP2B 84 5 10000
RZP1B 82 84 80000
LZPH 4 83 3.535e-02
LZPB 84 5 3.535e-02
EOUT 26 23 82 5 1
VOUT 23 5 0
ROUT 26 3 35
COUT 3 5 30.000000E-12
DOP 19 25 MDTH 400E-12
VOP 4 25 2.361965E+00
DON 24 19 MDTH 400E-12
VON 24 5 2.361965E+00
.ENDS

```

Table 6. Electrical characteristics with $V_{CC} = \pm 5\text{ V}$, $T_{amb} = 25^\circ\text{ C}$ (unless otherwise specified)

Symbol	Conditions	Value	Unit
V_{io}		0	mV
A_{vd}	$R_L = 600\ \Omega$	3.2	V/mV
I_{CC}	No load/amp	5.2	mA
V_{icm}		-3 to 4	V
V_{OH}	$R_L = 600\ \Omega$	+3.6	V
V_{OL}	$R_L = 600\ \Omega$	-3.6	V
I_{sink}	$V_o = 0\text{ V}$	40	mA
I_{source}	$V_o = 0\text{ V}$	40	mA
GBP	$R_L = 600\ \Omega$, $C_L = 15\text{ pF}$	147	MHz
SR	$R_L = 600\ \Omega$, $C_L = 15\text{ pF}$	110	V/ μs
ϕ_m	$R_L = 600\ \Omega$, $C_L = 15\text{ pF}$	42	Degrees

5.2 TSH94I with standby

The macromodel information provided in this section applies to TSH94I (model with standby).

```
* 1 INVERTING INPUT
* 2 NON-INVERTING INPUT
* 3 OUTPUT
* 4 POSITIVE POWER SUPPLY
* 5 NEGATIVE POWER SUPPLY
* 6 STANDBY
.SUBCKT TSH94 1 3 2 4 5 6 (analog)
*****
***** switch *****
.SUBCKT SWITCH20 10 IN OUT COM
.MODEL DIDEAL D N=0.1 IS=1E-08
DP IN 1 DIDEAL 400E-12
DN OUT 2 DIDEAL 400E-12
EP 1 OUT COM 10 2
EN 2 IN COM 10 2
RFUIT1 IN 1 1E+09
RFUIT2 OUT 2 1E+09
RCOM COM 0 1E+12
.ENDS SWITCH
***** inverter *****
.SUBCKT INV 20 10 IN OUT
.MODEL DIDEAL D N=0.1 IS=1E-08
RP1 20 15 1E+09
RN1 15 10 1E+09
RIN IN 10 1E+12
RIP IN 20 1E+12
DPINV OUT 20 DIDEAL 400E-12
DNINV 10 OUT DIDEAL 400E-12
GINV 0 OUT IN 15 -6.7E-7
CINV 0 OUT 210f
.ENDS INV
***** AOP *****
.MODEL MDTH D IS=1E-8 KF=1.809064E-15
CJO=10F
* INPUT STAGE
CIP 2 5 1.000000E-12
CIN 1 5 1.000000E-12
EIP 10 5 2 5 1
EIN 16 5 1 5 1
RIP 10 11 2.600000E-01
RIN 15 16 2.600000E-01
RIS 11 15 3.645298E-01
DIP 11 12 MDTH 400E-12
DIN 15 14 MDTH 400E-12
VOFP 12 13 DC 0.000000E+00
VOFN 1314DC 0
FPOL 13 5 VSTB 1E+03
CPS 11 15 2.986990E-10
```

```

DINN 17 13 MDTH 400E-12
VIN 17 5 2.000000e+00
DINR 15 18 MDTH 400E-12
VIP 4 18 1.000000E+00
FCP 4 5 VOFP 3.500000E+00
FCN 5 4 VOFN 3.500000E+00
ISTBO 4 5 130UA
FIBP 2 5 VOFP 1.000000E-02
FIBN 5 1 VOFN 1.000000E-02
* AMPLIFYING STAGE
FIP 5 19 VOFP 2.530000E+02
FIN 5 19 VOFN 2.530000E+02
RG1 19 120 3.160721E+03
XCOM1 4 0 120 5 COM SWITCH
RG2 19 121 3.160721E+03
XCOM2 4 0 4 121 COM SWITCH
CC 19 5 2.000000E-09
DOPM 19 22 MDTH 400E-12
DONM 21 19 MDTH 400E-12
HOPM 22 28 VOUT 1.504000E+03
VIPM 28 4 5.000000E+01
HONM 21 27 VOUT 1.400000E+03
VINM 5 27 5.000000E+01
***** ZP *****
RZP1 5 80 1E+06
RZP2 4 80 1E+06
GZP 5 82 19 80 2.5E-05
RZP2H 83 4 10000
RZP1H 83 82 80000
RZP2B 84 5 10000
RZP1B 82 84 80000
LZPH 4 83 3.535e-02
LZPB 84 5 3.535e-02
*****
EOUT 26 23 82 5 1
VOUT 23 5 0
ROUT 26 103 35
COUT 103 5 30.000000E-12
XCOM 4 0 103 3 COM SWITCH
DOP 19 25 MDTH 400E-12
VOP 4 25 2.361965E+00
DON 24 19 MDTH 400E-12
VON 24 5 2.361965E+00
***** STAND BY *****
RMI1 4 111 1E+7
RMI2 0 111 2E+7
RONOFF 6 60 1K
CONOGG 60 0 10p
RSTBIN 60 0 1E+12
ESTBIN 106 0 6 0 1
ESTBREF 106 107 111 0 1
DSTB1 107 108 MDTH 400E-12

```

```
VSTB 108 109 0
ISTB 109 0 1U
RSTB 109 110 1
DSTB2 0 110 MDTH 400E-12
XINV 4 0 6 COM INV
.ENDS
```

6 Package information

In order to meet environmental requirements, ST offers these devices in different grades of ECOPACK[®] packages, depending on their level of environmental compliance. ECOPACK[®] specifications, grade definitions and product status are available at: www.st.com. ECOPACK[®] is an ST trademark.

6.1 SO-16 package information

Figure 21. SO-16 package mechanical drawing

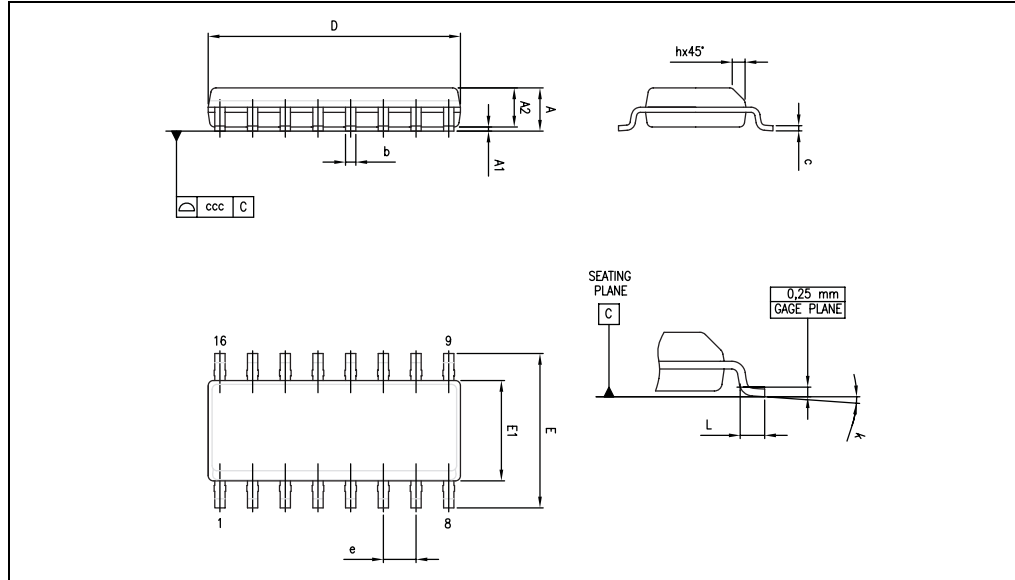

Table 7. SO-16 package mechanical data

Ref.	Dimensions					
	Millimeters			Inches		
	Min.	Typ.	Max.	Min.	Typ.	Max.
A			1.75			0.069
A1	0.10		0.25	0.004		0.010
A2	1.25			0.049		
b	0.31		0.51	0.012		0.020
c	0.17		0.25	0.007		0.010
D ⁽¹⁾	9.80	9.90	10.00	0.386	0.390	0.394
E	5.80	6.00	6.20	0.228	0.236	0.244
E1 ⁽²⁾	3.80	3.90	4.00	0.150	0.154	0.157
e		1.27			0.050	
h	0.25		0.50	0.010		0.020
L	0.40		1.27	0.016		0.050
k	0		8			
ccc			0.10			0.004

- Does not include mold flash, protrusions or gate burrs. Mold flash, protrusions or gate burrs not to exceed 0.15 mm in total.
- Does not include interlead flash or protrusions. Interlead flash or protrusions not to exceed 0.25 mm per side.

7 Ordering information

Table 8. Order codes

Part number	Temperature range	Package	Packing	Marking
TSH94ID TSH94IDT	-40° C to +125° C	SO-16	Tube or Tape & reel	H94I

8 Revision history

Table 9. Document revision history

Date	Revision	Changes
5-Oct-2000	1	Initial release.
6-Jun-2007	2	Table 8: Order codes updated and moved to Section 7: Ordering information . Automotive grade order codes added. Format update.
27-Nov-2007	3	Corrected unit in feature list on cover page from 110V/ms to 110V/ μ s. Added ESD parameters in Table 1: Absolute maximum ratings . Updated footnote in Table 8: Order codes .
11-May-2009	4	Removed TSH94IYD-IYDT from Table 8: Order codes .
01-Dec-2009	5	Changed marking from TSH94I to H94I in Table 8: Order codes .

Please Read Carefully:

Information in this document is provided solely in connection with ST products. STMicroelectronics NV and its subsidiaries ("ST") reserve the right to make changes, corrections, modifications or improvements, to this document, and the products and services described herein at any time, without notice.

All ST products are sold pursuant to ST's terms and conditions of sale.

Purchasers are solely responsible for the choice, selection and use of the ST products and services described herein, and ST assumes no liability whatsoever relating to the choice, selection or use of the ST products and services described herein.

No license, express or implied, by estoppel or otherwise, to any intellectual property rights is granted under this document. If any part of this document refers to any third party products or services it shall not be deemed a license grant by ST for the use of such third party products or services, or any intellectual property contained therein or considered as a warranty covering the use in any manner whatsoever of such third party products or services or any intellectual property contained therein.

UNLESS OTHERWISE SET FORTH IN ST'S TERMS AND CONDITIONS OF SALE ST DISCLAIMS ANY EXPRESS OR IMPLIED WARRANTY WITH RESPECT TO THE USE AND/OR SALE OF ST PRODUCTS INCLUDING WITHOUT LIMITATION IMPLIED WARRANTIES OF MERCHANTABILITY, FITNESS FOR A PARTICULAR PURPOSE (AND THEIR EQUIVALENTS UNDER THE LAWS OF ANY JURISDICTION), OR INFRINGEMENT OF ANY PATENT, COPYRIGHT OR OTHER INTELLECTUAL PROPERTY RIGHT.

UNLESS EXPRESSLY APPROVED IN WRITING BY AN AUTHORIZED ST REPRESENTATIVE, ST PRODUCTS ARE NOT RECOMMENDED, AUTHORIZED OR WARRANTED FOR USE IN MILITARY, AIR CRAFT, SPACE, LIFE SAVING, OR LIFE SUSTAINING APPLICATIONS, NOR IN PRODUCTS OR SYSTEMS WHERE FAILURE OR MALFUNCTION MAY RESULT IN PERSONAL INJURY, DEATH, OR SEVERE PROPERTY OR ENVIRONMENTAL DAMAGE. ST PRODUCTS WHICH ARE NOT SPECIFIED AS "AUTOMOTIVE GRADE" MAY ONLY BE USED IN AUTOMOTIVE APPLICATIONS AT USER'S OWN RISK.

Resale of ST products with provisions different from the statements and/or technical features set forth in this document shall immediately void any warranty granted by ST for the ST product or service described herein and shall not create or extend in any manner whatsoever, any liability of ST.

ST and the ST logo are trademarks or registered trademarks of ST in various countries.

Information in this document supersedes and replaces all information previously supplied.

The ST logo is a registered trademark of STMicroelectronics. All other names are the property of their respective owners.

© 2009 STMicroelectronics - All rights reserved

STMicroelectronics group of companies

Australia - Belgium - Brazil - Canada - China - Czech Republic - Finland - France - Germany - Hong Kong - India - Israel - Italy - Japan - Malaysia - Malta - Morocco - Philippines - Singapore - Spain - Sweden - Switzerland - United Kingdom - United States of America

www.st.com

