



TJM4558

WIDE BANDWIDTH DUAL BIPOLAR OPERATIONAL AMPLIFIERS

- INTERNALLY COMPENSATED
- SHORT-CIRCUIT PROTECTION
- GAIN AND PHASE MATCH BETWEEN AMPLIFIER
- LOW POWER CONSUMPTION
- PIN TO PIN COMPATIBLE WITH MC1458/LM358
- GAIN BANDWIDTH PRODUCT (at 100kHz) 5.5MHz

DESCRIPTION

The TJM4558 is a high performance monolithic dual operational amplifier.

The circuit combines all the outstanding features of the MC1458 and, in addition possesses three times the unity gain bandwidth of the industry standard.

ORDER CODE

| Part Number | Temperature Range | Package | | |
|-------------|-------------------|---------|---|---|
| | | N | D | P |
| TJM4558C | 0°C, +70°C | • | • | • |
| TJM4558I | -40°C, +105°C | • | • | • |

Example : TJM4558CN

N = Dual in Line Package (DIP)
D = Small Outline Package (SO) - also available in Tape & Reel (DT)
P = Thin Shrink Small Outline Package (TSSOP) - only available in Tape & Reel (PT)

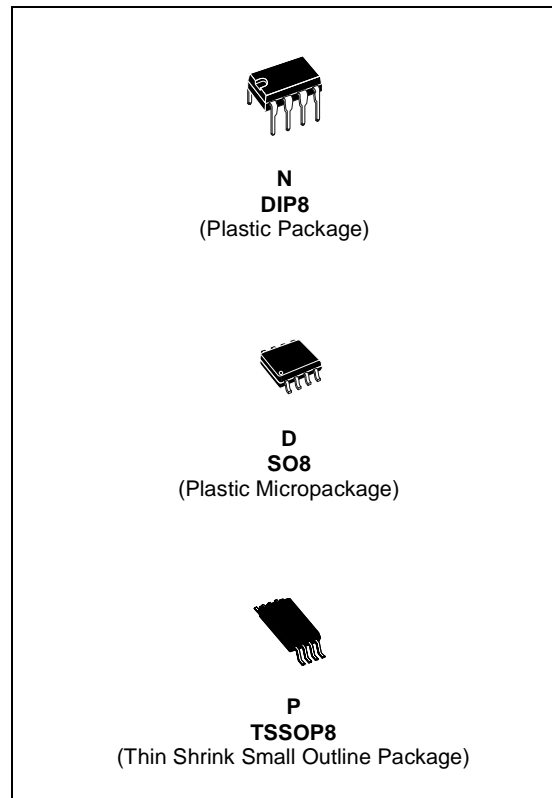

PIN CONNECTIONS (top view)

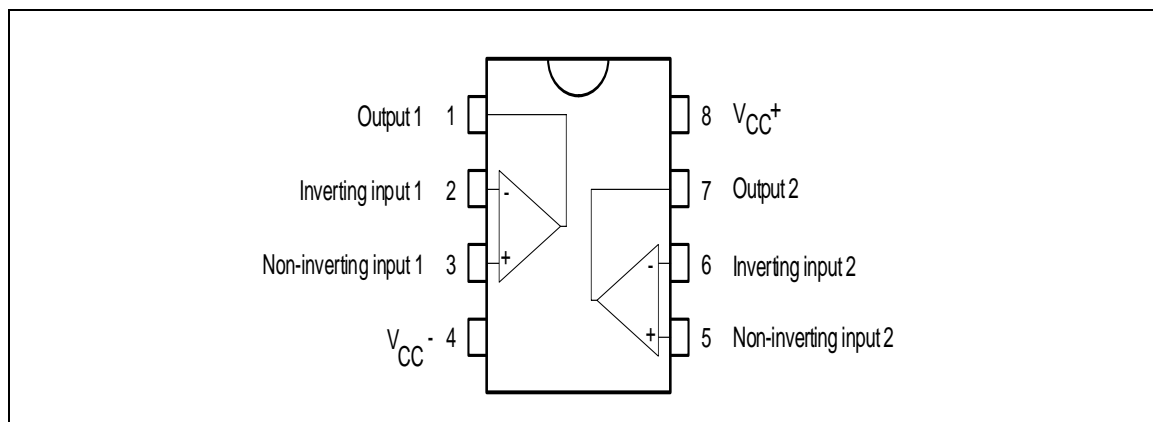

TJM4558

SCHEMATIC DIAGRAM (1/2 TJM4558)

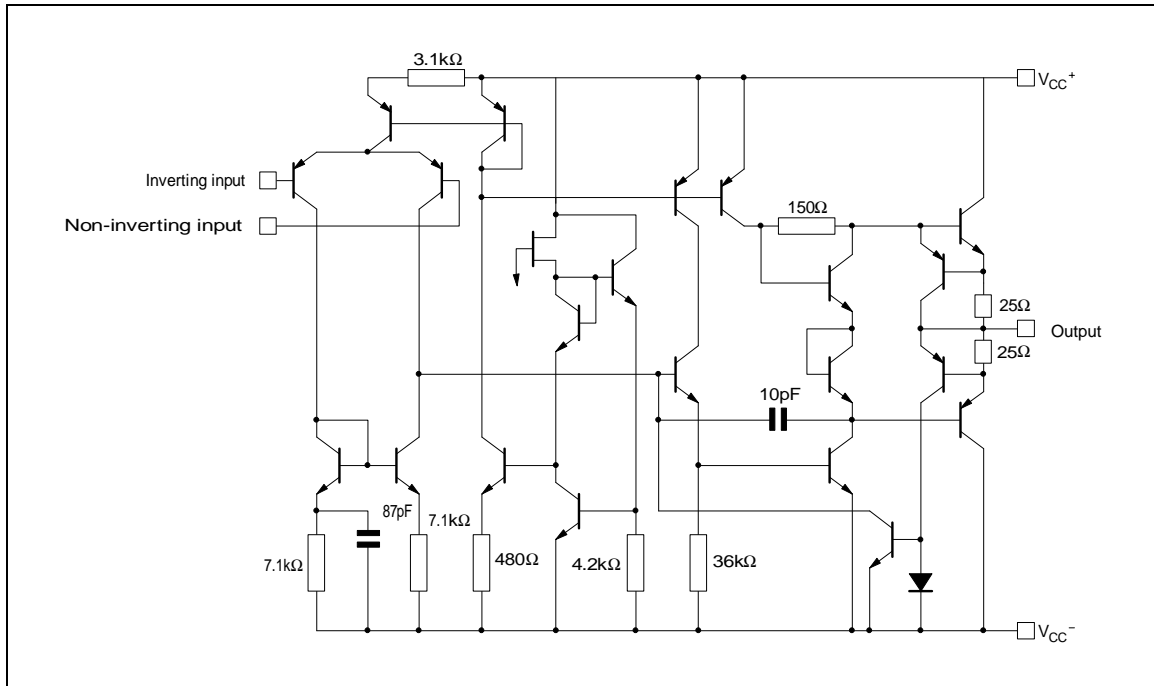

ABSOLUTE MAXIMUM RATINGS

| Symbol | Parameter | TJM4558I | TJM4558C | Unit |
|------------|--------------------------------------|-------------|----------|------|
| V_{CC} | Supply Voltage | ±22 | | V |
| V_i | Input Voltage | ±15 | | V |
| V_{id} | Differential Input Voltage | ±30 | | V |
| P_{tot} | Power Dissipation | 680 | | mW |
| | Output Short Circuit Duration | Infinite | | |
| T_{oper} | Operating Free-Air Temperature Range | -40 to +105 | 0 to +70 | °C |
| T_{stg} | Storage Temperature | -65 to +150 | | °C |

ELECTRICAL CHARACTERISTICS

$V_{CC} = \pm 15V$, $T_{amb} = 25^\circ C$ (unless otherwise specified)

| Symbol | Parameter | Min. | Typ. | Max. | Unit |
|----------|--|----------|-----------|--------|------|
| V_{io} | Input Offset Voltage ($R_s \leq 10k\Omega$) $T_{amb} = +25^\circ C$ $T_{min.} \leq T_{amb} \leq T_{max.}$ | | 1 | 5 6 | mV |
| I_{io} | Input Offset Current $T_{amb} = +25^\circ C$ $T_{min.} \leq T_{amb} \leq T_{max.}$ | | 20 40 | 100 | nA |
| I_{ib} | Input Bias Current $T_{amb} = +25^\circ C$ $T_{min.} \leq T_{amb} \leq T_{max.}$ | | 50 100 | 400 | nA |
| A_{vd} | Large Signal Voltage Gain ($R_L = 2k\Omega$, $V_o = \pm 10V$) $T_{amb} = +25^\circ C$ $T_{min.} \leq T_{amb} \leq T_{max.}$ | 50 25 | 200 | | V/mV |

| Symbol | Parameter | Min. | Typ. | Max. | Unit |
|-----------------|--|--|--|----------------------|------------------------|
| SVR | Supply Voltage Rejection Ratio ($R_s \leq 10k\Omega$) $T_{amb} = +25^\circ C$ $T_{min} \leq T_{amb} \leq T_{max}$. | | 90 77 | | dB |
| I_{CC} | Supply Current, all amplifiers, no load $T_{amb} = +25^\circ C$ $T_{min} \leq T_{amb} \leq T_{max}$. | | 2.3 4 | 4.5 | mA |
| V_{icm} | Input Common Mode Voltage Range $T_{amb} = +25^\circ C$ $T_{min} \leq T_{amb} \leq T_{max}$. | ± 12 ± 12 | | | V |
| CMR | Common-mode Rejection Ratio ($R_s \leq 10k\Omega$) $T_{amb} = +25^\circ C$ $T_{min} \leq T_{amb} \leq T_{max}$. | | 90 70 | | dB |
| I_{os} | Output Short Circuit Current | 10 | 20 | | mA |
| V_o | Output Voltage Swing $T_{amb} = +25^\circ C$ $T_{min} \leq T_{amb} \leq T_{max}$. | $R_L = 10k\Omega$ $R_L = 2k\Omega$ $R_L = 10k\Omega$ $R_L = 2k\Omega$ | ± 12 ± 10 ± 12 ± 10 | ± 14 ± 13 | V |
| SR | Slew Rate ($V_i = \pm 10$, $R_L = 2k\Omega$, $C_L = 100pF$, $T_{amb} = 25^\circ C$, unity gain) | | 2.2 | | V/ μs |
| t_r | Rise Time ($V_i = \pm 20mV$, $R_L = 2k\Omega$, $C_L = 100pF$, $T_{amb} = 25^\circ C$, unity gain) | | 0.3 | | μs |
| K_{OV} | Overshoot ($V_i = \pm 20mV$, $R_L = 2k\Omega$, $C_L = 100pF$, $T_{amb} = 25^\circ C$, unity gain) | | 15 | | % |
| R_i | Input Resistance | 0.3 | 2 | | M Ω |
| C_i | Input Capacitance | | 1.4 | | pF |
| R_o | Output Resistance | | 75 | | Ω |
| B | Unity Gain Bandwidth | | 2.8 | | MHz |
| GBP | Gain Bandwidth Product ($V_i = 10mV$, $R_L = 2k\Omega$, $C_L = 100pF$, $f = 100kHz$, $T_{amb} = 25^\circ C$) | | 5.5 | | MHz |
| THD | Total Harmonic Distortion ($f = 1kHz$, $A_v = 20dB$, $R_L = 2k\Omega$, $V_o = 2V_{pp}$, $C_L = 100pF$, $T_{amb} = 25^\circ C$) | | 0.008 | | % |
| e_n | Equivalent Input Noise Voltage ($R_S = 100\Omega$, $f = 1kHz$) | | 12 | | $\frac{nV}{\sqrt{Hz}}$ |
| V_{O1}/V_{O2} | Channel Separation | | 120 | | dB |

TRANSIENT RESPONSE TEST CIRCUIT

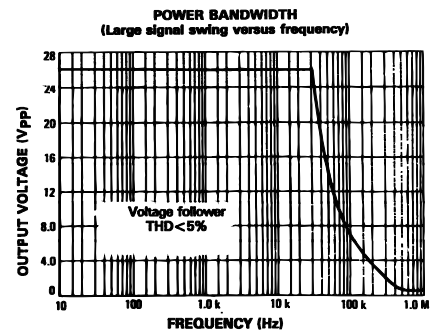
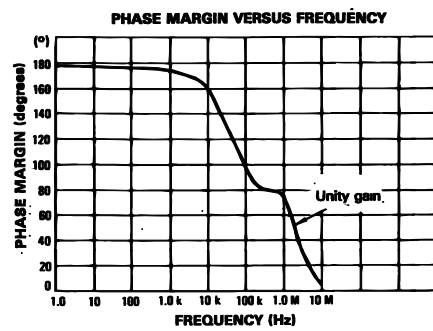
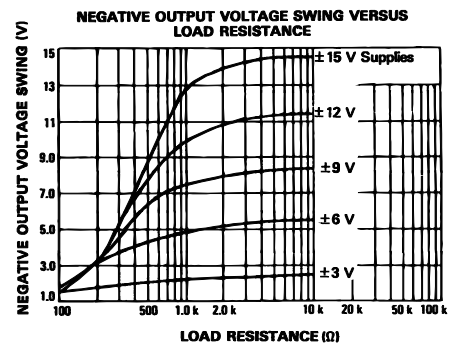
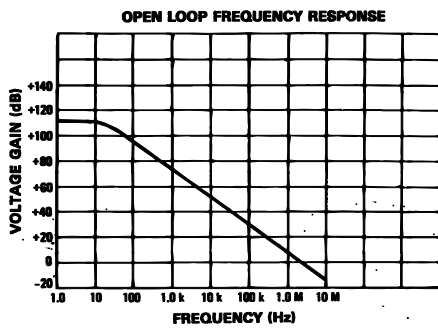
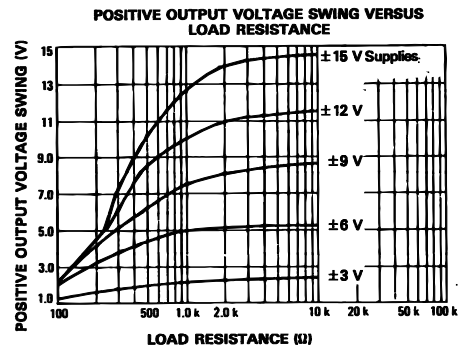
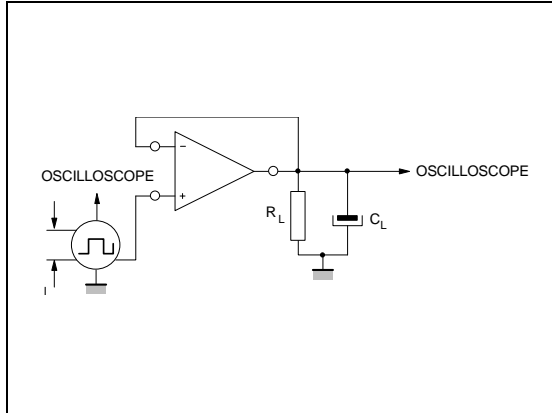

PACKAGE MECHANICAL DATA

| Plastic DIP-8 MECHANICAL DATA | | | | | | |
|-------------------------------|------|------|------|-------|-------|-------|
| DIM. | mm. | | | inch | | |
| | MIN. | TYP. | MAX. | MIN. | TYP. | MAX. |
| A | | 3.3 | | | 0.130 | |
| a1 | 0.7 | | | 0.028 | | |
| B | 1.39 | | 1.65 | 0.055 | | 0.065 |
| B1 | 0.91 | | 1.04 | 0.036 | | 0.041 |
| b | | 0.5 | | | 0.020 | |
| b1 | 0.38 | | 0.5 | 0.015 | | 0.020 |
| D | | | 9.8 | | | 0.386 |
| E | | 8.8 | | | 0.346 | |
| e | | 2.54 | | | 0.100 | |
| e3 | | 7.62 | | | 0.300 | |
| e4 | | 7.62 | | | 0.300 | |
| F | | | 7.1 | | | 0.280 |
| I | | | 4.8 | | | 0.189 |
| L | | 3.3 | | | 0.130 | |
| Z | 0.44 | | 1.6 | 0.017 | | 0.063 |

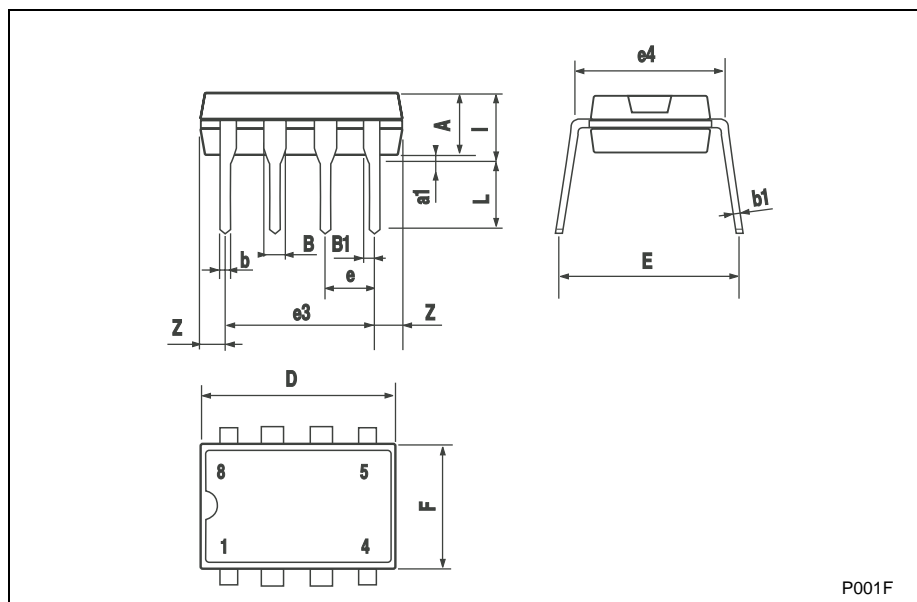

P001F

PACKAGE MECHANICAL DATA

| SO-8 MECHANICAL DATA | | | | | | |
|----------------------|-----------|------|------|-------|-------|-------|
| DIM. | mm. | | | inch | | |
| | MIN. | TYP. | MAX. | MIN. | TYP. | MAX. |
| A | 1.35 | | 1.75 | 0.053 | | 0.069 |
| A1 | 0.10 | | 0.25 | 0.04 | | 0.010 |
| A2 | 1.10 | | 1.65 | 0.043 | | 0.065 |
| B | 0.33 | | 0.51 | 0.013 | | 0.020 |
| C | 0.19 | | 0.25 | 0.007 | | 0.010 |
| D | 4.80 | | 5.00 | 0.189 | | 0.197 |
| E | 3.80 | | 4.00 | 0.150 | | 0.157 |
| e | | 1.27 | | | 0.050 | |
| H | 5.80 | | 6.20 | 0.228 | | 0.244 |
| h | 0.25 | | 0.50 | 0.010 | | 0.020 |
| L | 0.40 | | 1.27 | 0.016 | | 0.050 |
| k | 8° (max.) | | | | | |
| ddd | | | 0.1 | | | 0.04 |

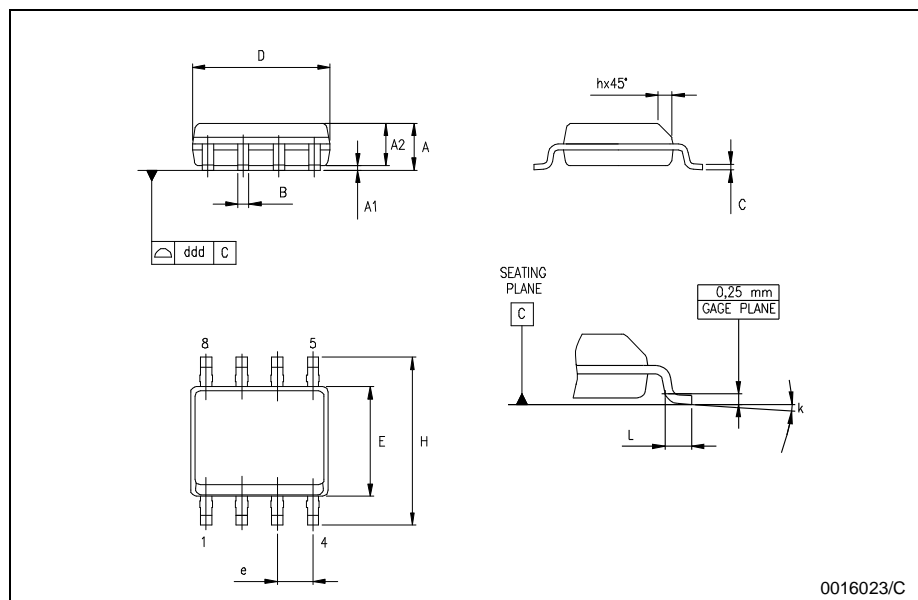

PACKAGE MECHANICAL DATA

| TSSOP8 MECHANICAL DATA | | | | | | |
|------------------------|------|------|------|-------|--------|-------|
| DIM. | mm. | | | inch | | |
| | MIN. | TYP. | MAX. | MIN. | TYP. | MAX. |
| A | | | 1.2 | | | 0.047 |
| A1 | 0.05 | | 0.15 | 0.002 | | 0.006 |
| A2 | 0.80 | 1.00 | 1.05 | 0.031 | 0.039 | 0.041 |
| b | 0.19 | | 0.30 | 0.007 | | 0.012 |
| c | 0.09 | | 0.20 | 0.004 | | 0.008 |
| D | 2.90 | 3.00 | 3.10 | 0.114 | 0.118 | 0.122 |
| E | 6.20 | 6.40 | 6.60 | 0.244 | 0.252 | 0.260 |
| E1 | 4.30 | 4.40 | 4.50 | 0.169 | 0.173 | 0.177 |
| e | | 0.65 | | | 0.0256 | |
| K | 0° | | 8° | 0° | | 8° |
| L | 0.45 | 0.60 | 0.75 | 0.018 | 0.024 | 0.030 |
| L1 | | 1 | | | 0.039 | |

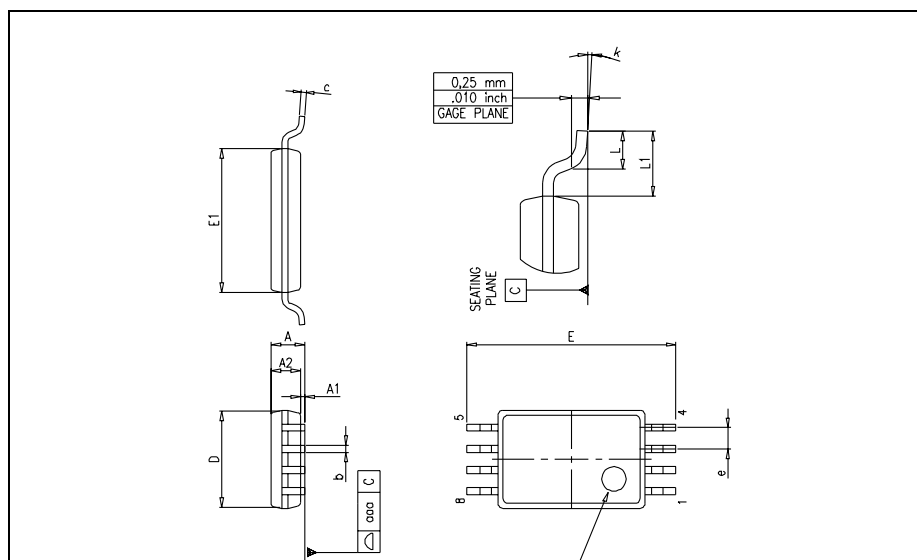

Information furnished is believed to be accurate and reliable. However, STMicroelectronics assumes no responsibility for the consequences of use of such information nor for any infringement of patents or other rights of third parties which may result from its use. No license is granted by implication or otherwise under any patent or patent rights of STMicroelectronics. Specifications mentioned in this publication are subject to change without notice. This publication supersedes and replaces all information previously supplied. STMicroelectronics products are not authorized for use as critical components in life support devices or systems without express written approval of STMicroelectronics.

The ST logo is a registered trademark of STMicroelectronics
All other names are the property of their respective owners.

© 2003 STMicroelectronics - All Rights Reserved

STMicroelectronics GROUP OF COMPANIES

Australia - Belgium - Brazil - Canada - China - Czech Republic - Finland - France - Germany
Hong Kong - India - Israel - Italy - Japan - Malaysia - Malta - Morocco - Singapore - Spain
Sweden - Switzerland - United Kingdom - United States

<http://www.st.com>

