



TS27M4C, TS27M4I, TS27M4M

Precision low power CMOS quad operational amplifiers

Features

- Low power consumption: 150 $\mu\text{A}/\text{op}$
- Output voltage can swing to ground
- Excellent phase margin on capacitive loads
- Unity gain stable
- Two input offset voltage selections

Description

These devices are low cost, low power quad operational amplifiers designed to operate with single or dual supplies. These operational amplifiers use the ST silicon gate CMOS process allowing an excellent consumption-speed ratio. These series are ideally suited for low consumption applications.

Three power consumptions are available thus offering the best consumption-speed ratio for your application:

- $I_{CC} = 10 \mu\text{A}/\text{amp}$: TS27L4 (very low power)
- $I_{CC} = 150 \mu\text{A}/\text{amp}$: TS27M4 (low power)
- $I_{CC} = 1 \text{ mA}/\text{amp}$: TS274 (standard)

These CMOS amplifiers offer very high input impedance and extremely low input currents. The major advantage versus JFET devices is the very low input currents drift with temperature (see [Figure 4 on page 7](#)).

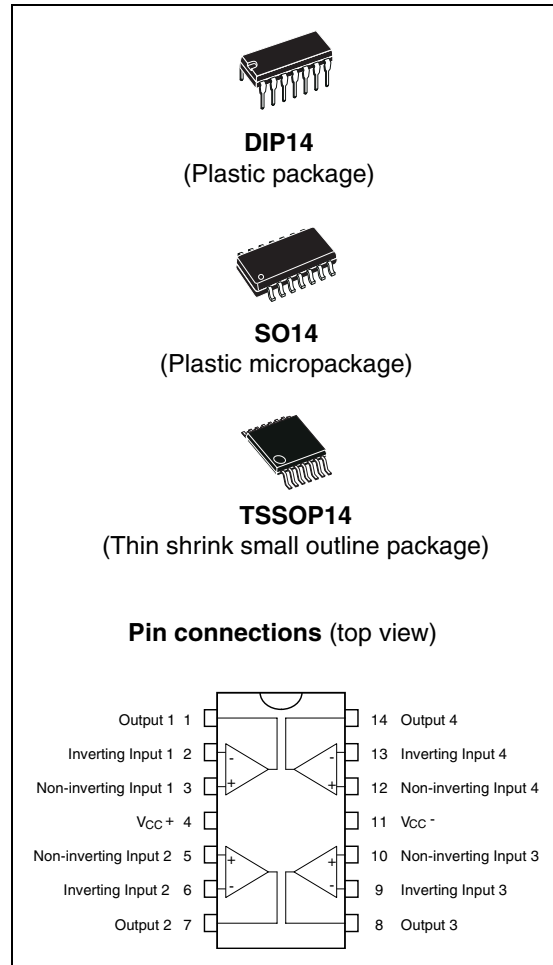

1 Circuit schematics

Figure 1. Block diagram

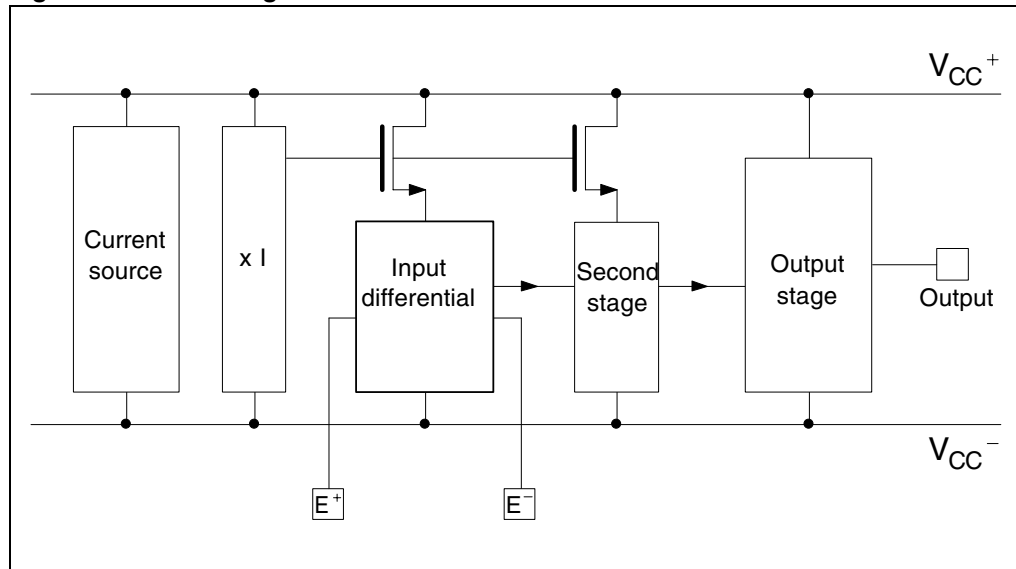
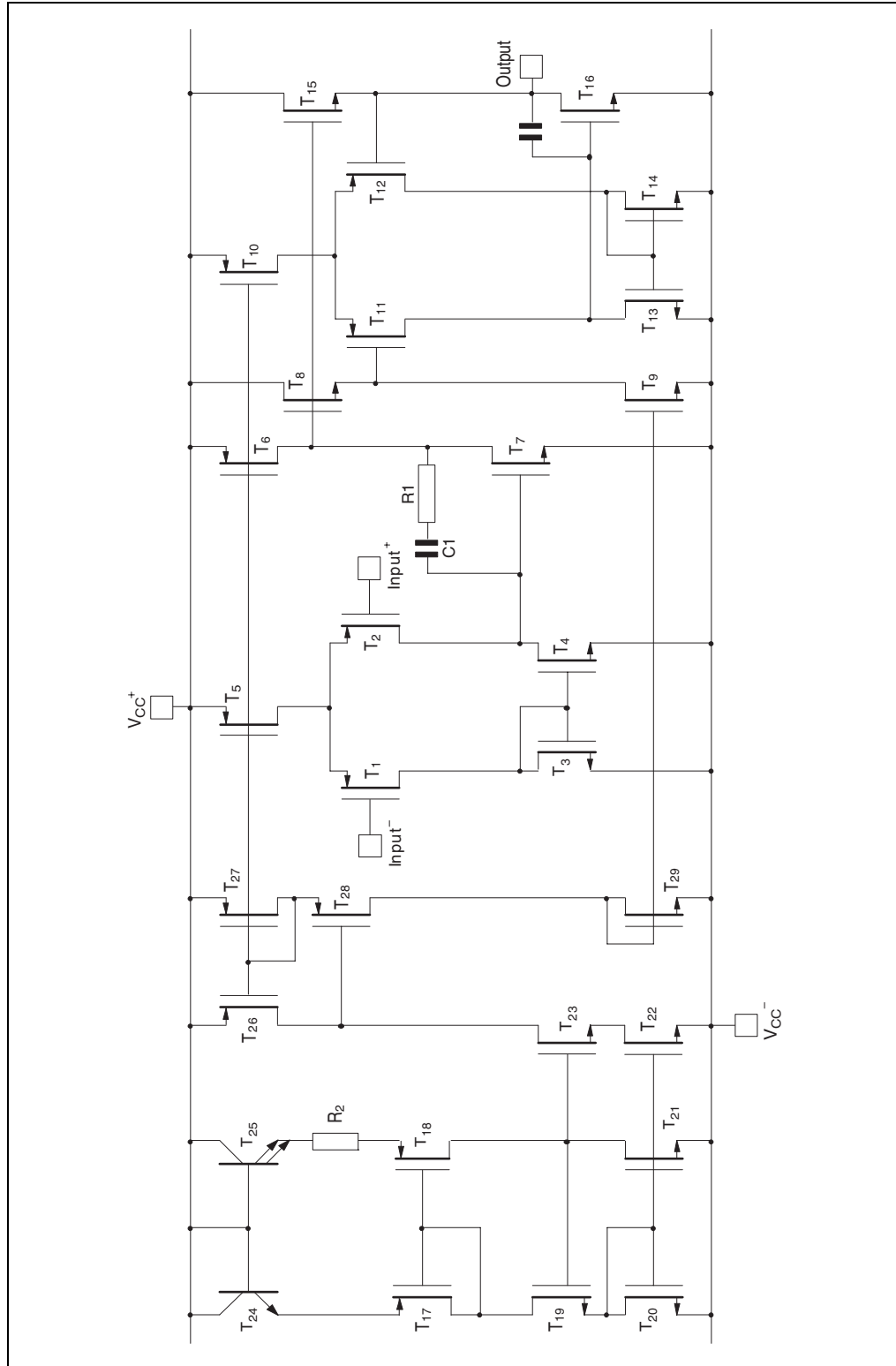

Figure 2. Schematic diagram (for 1/4 TS27M4)



2 Absolute maximum ratings and operating conditions

Table 1. Absolute maximum ratings (AMR)

Symbol	Parameter	TS27M4C/AC	TS27M4I/AI	TS27M4M/AM	Unit
V_{CC+}	Supply voltage ⁽¹⁾	18			V
V_{id}	Differential input voltage ⁽²⁾	±18			V
V_{in}	Input voltage ⁽³⁾	-0.3 to 18			V
I_o	Output current for $V_{CC+} \geq 15V$	±30			mA
I_{in}	Input current	±5			mA
T_{oper}	Operating free-air temperature range	0 to +70	-40 to +125	-55 to +125	°C
T_{stg}	Storage temperature range	-65 to +150			°C
R_{thja}	Thermal resistance junction to ambient ⁽⁴⁾				°C/W
	SO-14	105			
	TSSOP14	100			
R_{thjc}	Thermal resistance junction to case ⁽⁴⁾				°C/W
	SO-14	31			
	TSSOP14	32			
ESD	HBM: human body model ⁽⁵⁾	1			kV
	MM: machine model ⁽⁶⁾	100			V
	CDM: charged device model ⁽⁷⁾	1.5			kV

1. All values, except differential voltage are with respect to network ground terminal.
2. Differential voltages are the non-inverting input terminal with respect to the inverting input terminal.
3. The magnitude of the input and the output voltages must never exceed the magnitude of the positive supply voltage.
4. Short-circuits can cause excessive heating and destructive dissipation. Values are typical.
5. Human body model: a 100 pF capacitor is charged to the specified voltage, then discharged through a 1.5kΩ resistor between two pins of the device. This is done for all couples of connected pin combinations while the other pins are floating.
6. Machine model: a 200 pF capacitor is charged to the specified voltage, then discharged directly between two pins of the device with no external series resistor (internal resistor < 5Ω). This is done for all couples of connected pin combinations while the other pins are floating.
7. Charged device model: all pins and the package are charged together to the specified voltage and then discharged directly to the ground through only one pin. This is done for all pins.

Table 2. Operating conditions

Symbol	Parameter	Value	Unit
V_{CC+}	Supply voltage	3 to 16	V
V_{icm}	Common mode input voltage range	0 to $V_{CC+} - 1.5$	V

3 Electrical characteristics

Table 3. $V_{CC}^+ = +10\text{ V}$, $V_{CC}^- = 0\text{ V}$, $T_{\text{amb}} = +25^\circ\text{ C}$ (unless otherwise specified)

Symbol	Parameter	TS27M4C/AC			TS27M4I/AI TS27M4M/AM			Unit
		Min.	Typ.	Max.	Min.	Typ.	Max.	
V_{io}	Input offset voltage $V_O = 1.4\text{V}$, $V_{ic} = 0\text{V}$ TS27M4C/I/M TS27M4AC/AI/AM $T_{\text{min}} \leq T_{\text{amb}} \leq T_{\text{max}}$		1.1 0.9	10 5		1.1 0.9	10 5	mV
	TS27M4C/I/M TS27M4AC/AI/AM			12 6.5			12 6.5	
DV_{io}	Input offset voltage drift		2			2		$\mu\text{V}/^\circ\text{C}$
I_{io}	Input offset current note ⁽¹⁾ $V_{ic} = 5\text{V}$, $V_O = 5\text{V}$ $T_{\text{min}} \leq T_{\text{amb}} \leq T_{\text{max}}$		1	100		1	200	pA
I_{ib}	Input bias current ⁽¹⁾ $V_{ic} = 5\text{V}$, $V_O = 5\text{V}$ $T_{\text{min}} \leq T_{\text{amb}} \leq T_{\text{max}}$		1	150		1	300	pA
V_{OH}	High level output voltage $V_{id} = 100\text{mV}$, $R_L = 100\text{k}\Omega$ $T_{\text{min}} \leq T_{\text{amb}} \leq T_{\text{max}}$	8.7 8.6	8.9		8.7 8.5	8.9		V
V_{OL}	Low level output voltage $V_{id} = -100\text{mV}$			50			50	mV
A_{vd}	Large signal voltage gain $V_{ic} = 5\text{V}$, $R_L = 100\text{k}\Omega$, $V_O = 1\text{V}$ to 6V $T_{\text{min}} \leq T_{\text{amb}} \leq T_{\text{max}}$	30 20	50		30 10	50		V/mV
GBP	Gain bandwidth product $A_v = 40\text{dB}$, $R_L = 100\text{k}\Omega$, $C_L = 100\text{pF}$, $f_{in} = 100\text{kHz}$		1			1		MHz
CMR	Common mode rejection ratio $V_{ic} = 1\text{V}$ to 7.4V , $V_O = 1.4\text{V}$	65	80		65	80		dB
SVR	Supply voltage rejection ratio $V_{CC}^+ = 5\text{V}$ to 10V , $V_O = 1.4\text{V}$	60	80		60	80		dB
I_{CC}	Supply current (per amplifier) $A_v = 1$, no load, $V_O = 5\text{V}$ $T_{\text{min}} \leq T_{\text{amb}} \leq T_{\text{max}}$		150	200 250		150	200 300	μA
I_o	Output short-circuit current $V_O = 0\text{V}$, $V_{id} = 100\text{mV}$		60			60		mA
I_{sink}	Output sink current $V_O = V_{CC}$, $V_{id} = -100\text{mV}$		45			45		mA
SR	Slew rate at unity gain $R_L = 100\text{k}\Omega$, $C_L = 100\text{pF}$, $V_i = 3$ to 7V		0.6			0.6		$\text{V}/\mu\text{s}$

Table 3. $V_{CC}^+ = +10\text{ V}$, $V_{CC}^- = 0\text{ V}$, $T_{\text{amb}} = +25^\circ\text{ C}$ (unless otherwise specified) (continued)

Symbol	Parameter	TS27M4C/AC			TS27M4I/AI TS27M4M/AM			Unit
		Min.	Typ.	Max.	Min.	Typ.	Max.	
ϕ_m	Phase margin at unity gain $A_v = 40\text{dB}$, $R_L = 100\text{k}\Omega$, $C_L = 100\text{pF}$		45			45		Degrees
K_{OV}	Overshoot factor		30			30		%
e_n	Equivalent input noise voltage $f = 1\text{kHz}$, $R_s = 100\Omega$		38			38		$\frac{\text{nV}}{\sqrt{\text{Hz}}}$
V_{O1}/V_{O2}	Channel separation		120			120		dB

1. Maximum values include unavoidable inaccuracies of the industrial tests.

Figure 3. Supply current (each amplifier) versus supply voltage

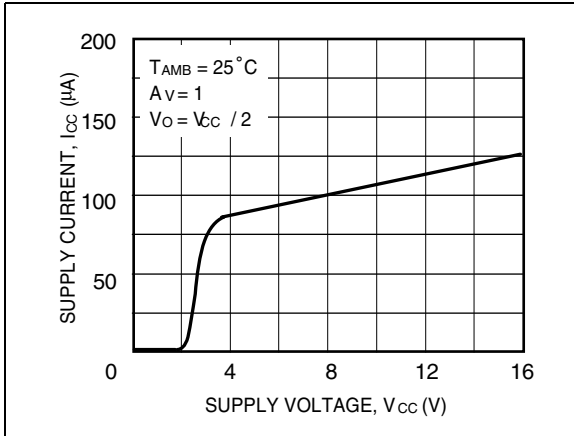

Figure 4. Input bias current versus free air temperature

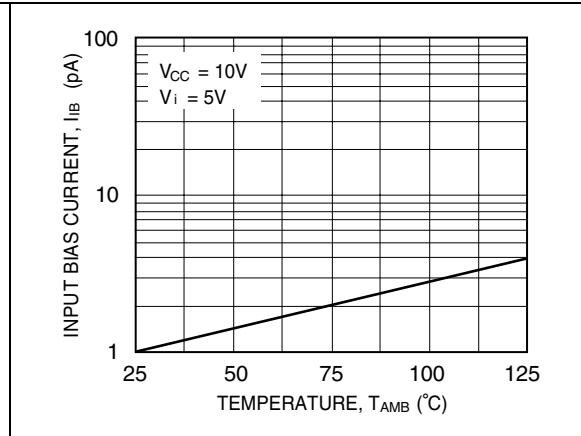

Figure 5. High level output voltage versus high level output current

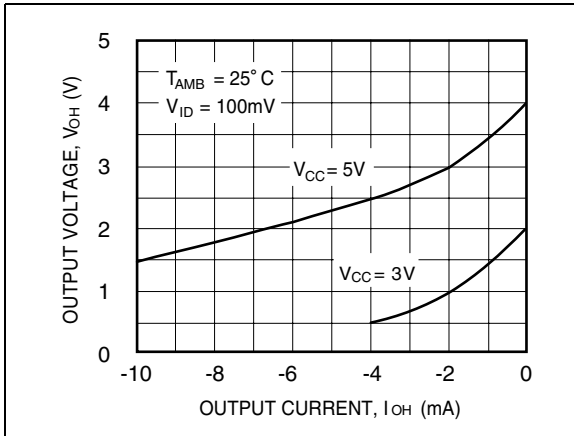

Figure 6. High level output voltage versus high level output current

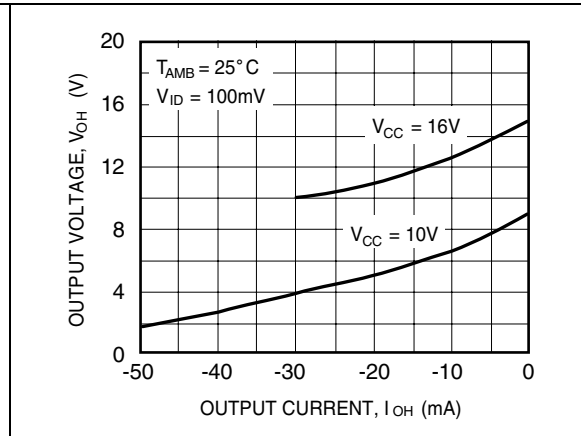

Figure 7. Low level output voltage versus low level output current

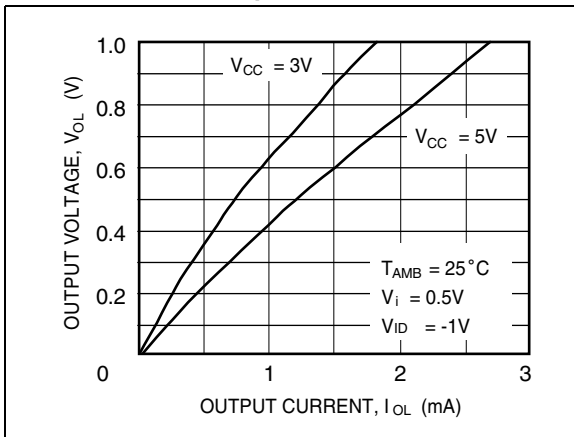

Figure 8. Low level output voltage versus low level output current

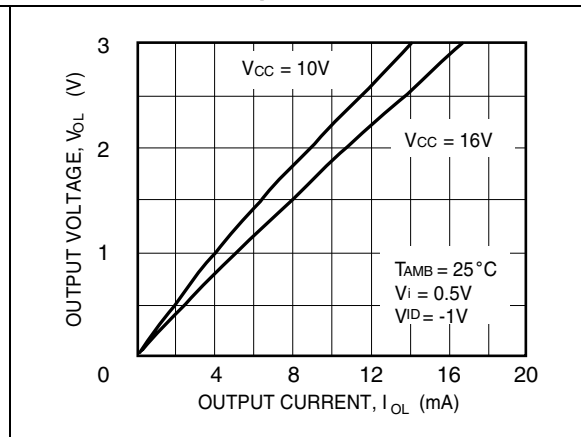

Figure 9. Open loop frequency response and phase shift **Figure 10. Gain bandwidth product versus supply voltage**

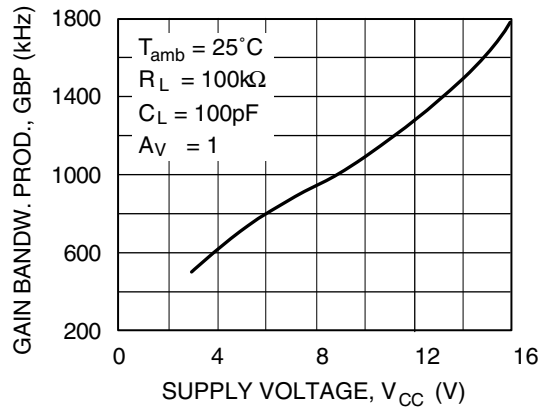
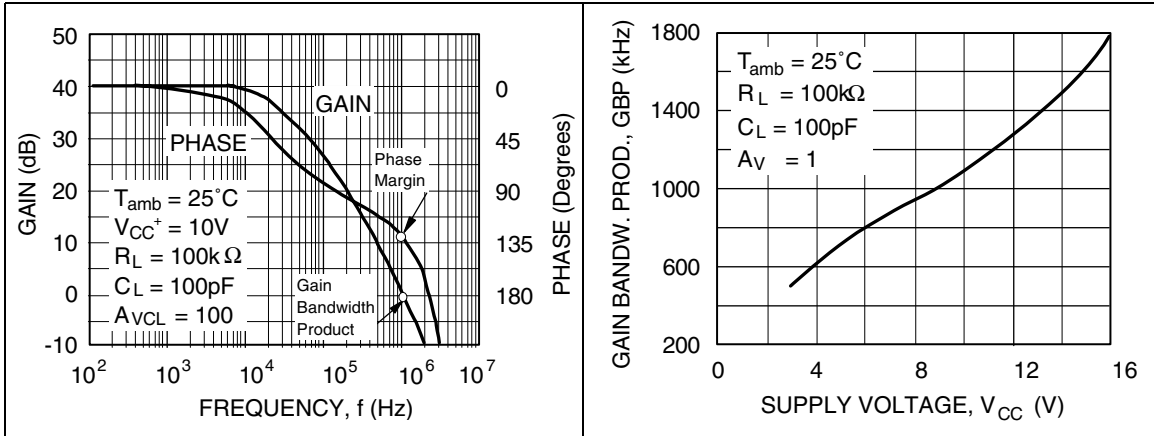

Figure 11. Phase margin versus supply voltage **Figure 12. Phase margin versus capacitive load**

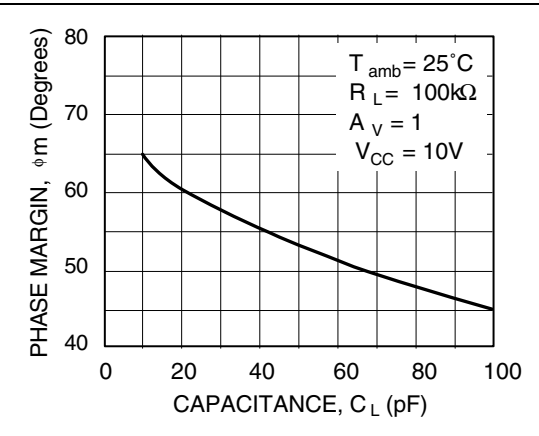
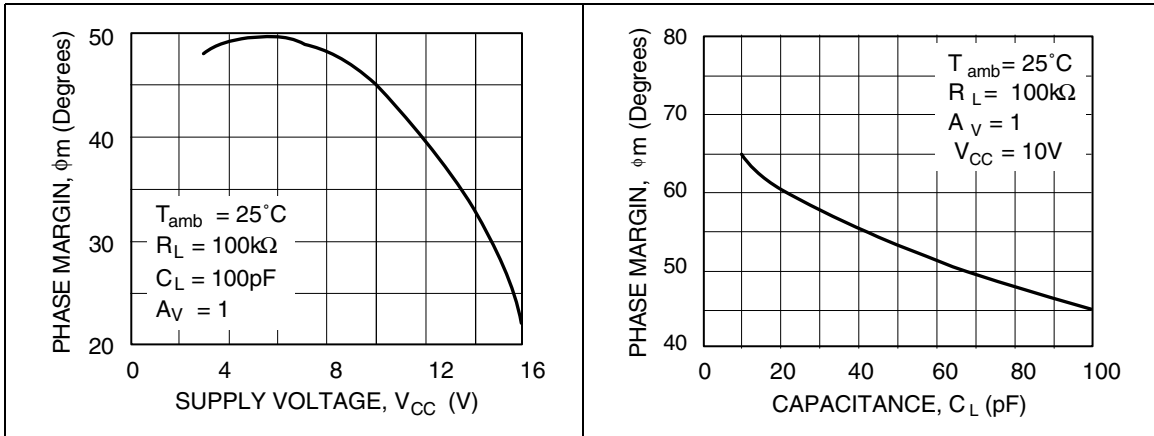
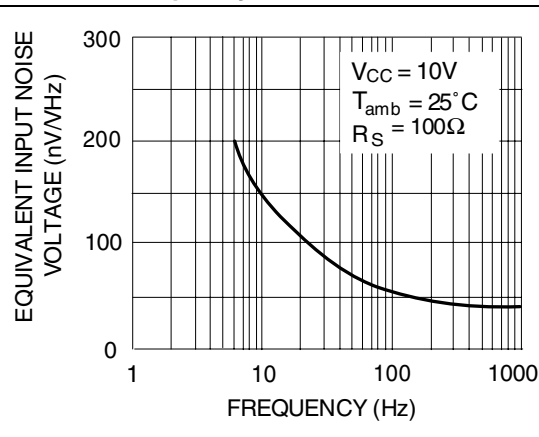
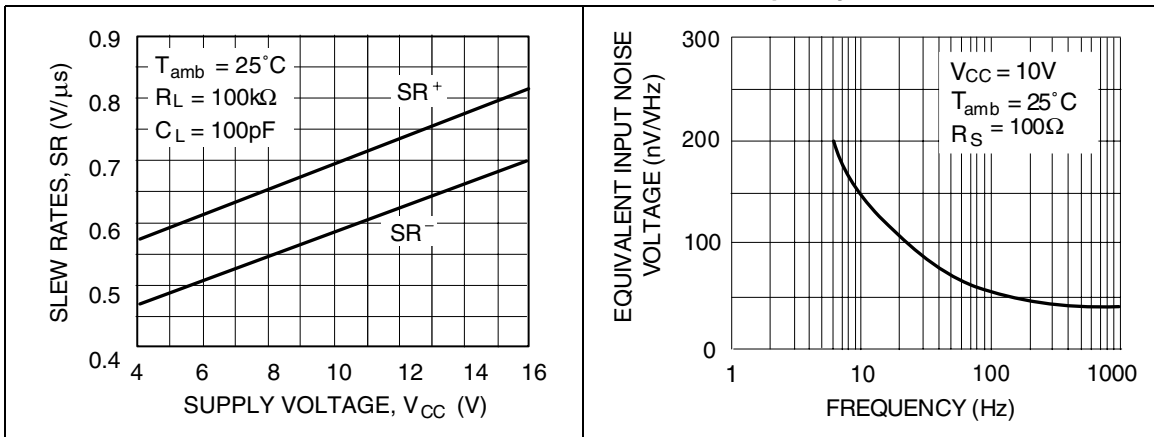

Figure 13. Slew rate versus supply voltage **Figure 14. Input voltage noise versus frequency**



4 Package information

In order to meet environmental requirements, STMicroelectronics offers these devices in ECOPACK® packages. These packages have a lead-free second level interconnect. The category of second level interconnect is marked on the package and on the inner box label, in compliance with JEDEC Standard JESD97. The maximum ratings related to soldering conditions are also marked on the inner box label. ECOPACK is an STMicroelectronics trademark. ECOPACK specifications are available at: www.st.com.

4.1 DIP14 package information

Figure 15. DIP14 package mechanical drawing

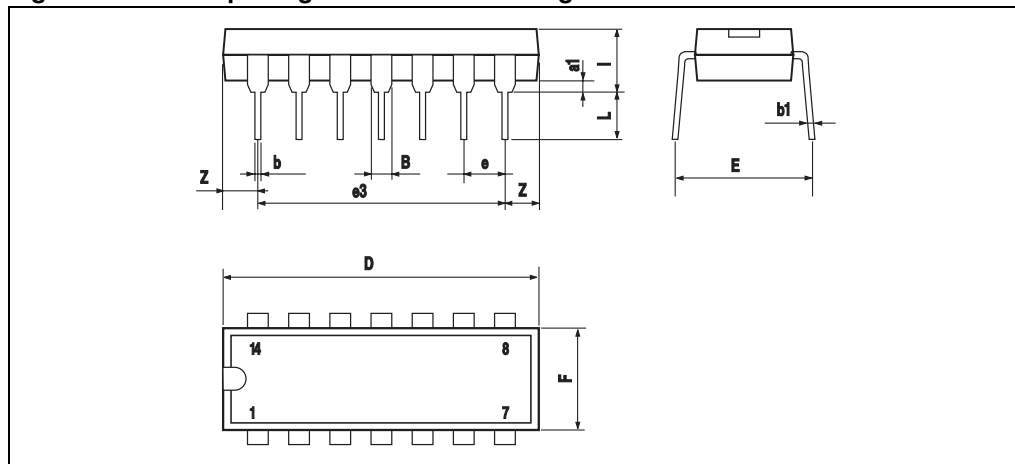

Table 4. DIP14 package mechanical data

Ref.	Millimeters			Inches		
	Min.	Typ.	Max.	Min.	Typ.	Max.
a1	0.51			0.020		
B	1.39		1.65	0.055		0.065
b		0.5			0.020	
b1		0.25			0.010	
D			20			0.787
E		8.5			0.335	
e		2.54			0.100	
e3		15.24			0.600	
F			7.1			0.280
l			5.1			0.201
L		3.3			0.130	
Z	1.27		2.54	0.050		0.100

4.2 SO-14 package information

Figure 16. SO-14 package mechanical drawing

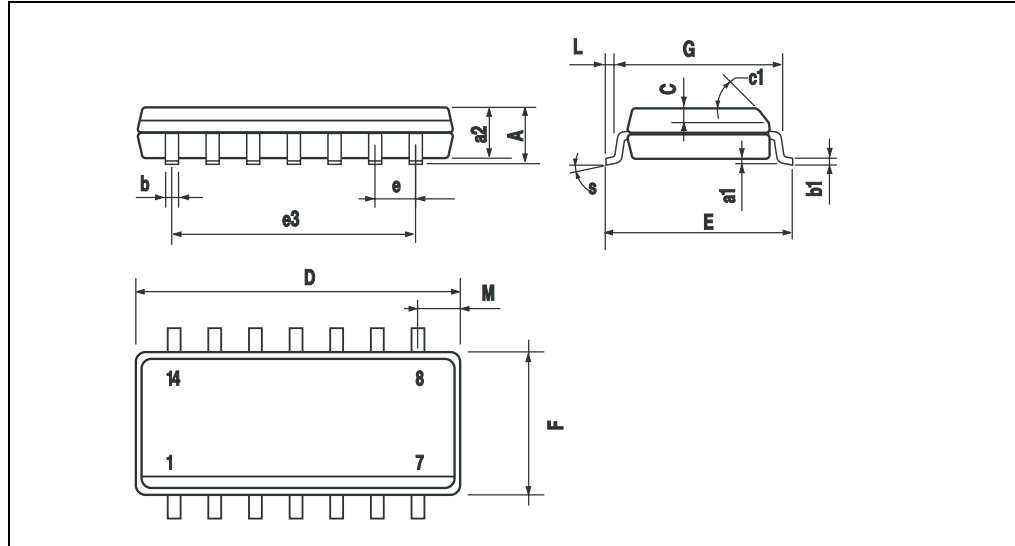

Table 5. SO-14 package mechanical data

Ref.	Dimensions					
	Millimeters			Inches		
	Min.	Typ.	Max.	Min.	Typ.	Max.
A			1.75			0.068
a1	0.1		0.2	0.003		0.007
a2			1.65			0.064
b	0.35		0.46	0.013		0.018
b1	0.19		0.25	0.007		0.010
C		0.5			0.019	
c1	45° (typ.)					
D	8.55		8.75	0.336		0.344
E	5.8		6.2	0.228		0.244
e		1.27			0.050	
e3		7.62			0.300	
F	3.8		4.0	0.149		0.157
G	4.6		5.3	0.181		0.208
L	0.5		1.27	0.019		0.050
M			0.68			0.026
S	8° (max.)					

4.3 TSSOP14 package information

Figure 17. TSSOP14 package mechanical drawing

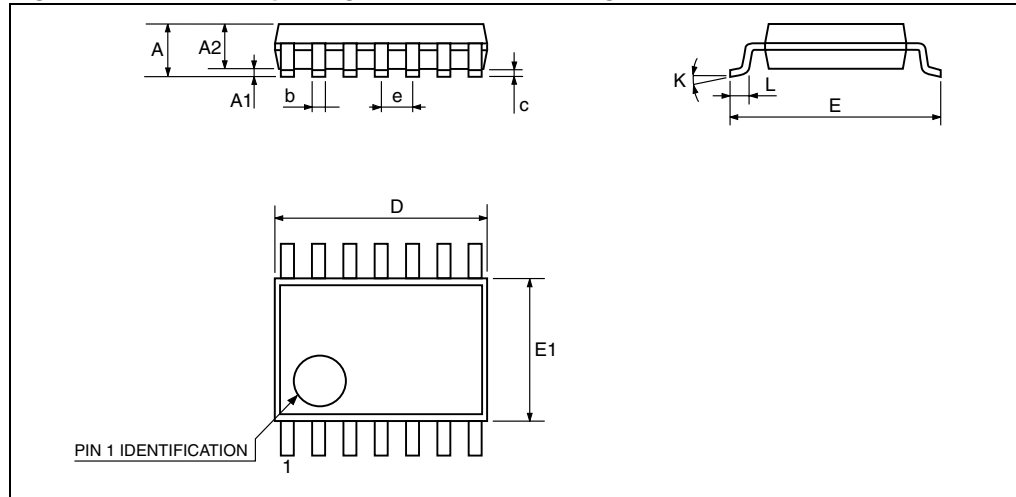

Figure 18. TSSOP14 package mechanical data

Ref.	Dimensions					
	Millimeters			Inches		
	Min.	Typ.	Max.	Min.	Typ.	Max.
A			1.2			0.047
A1	0.05		0.15	0.002	0.004	0.006
A2	0.8	1	1.05	0.031	0.039	0.041
b	0.19		0.30	0.007		0.012
c	0.09		0.20	0.004		0.0089
D	4.9	5	5.1	0.193	0.197	0.201
E	6.2	6.4	6.6	0.244	0.252	0.260
E1	4.3	4.4	4.48	0.169	0.173	0.176
e		0.65 BSC			0.0256 BSC	
K	0°		8°	0°		8°
L1	0.45	0.60	0.75	0.018	0.024	0.030

5 Ordering information

Table 6. Order codes

Order code	Temperature range	Package	Packing	Marking
TS27M4CD TS27M4CDT	0°C, +70°C	SO-14	Tube or Tape & reel	27M4C
TS27M4ACD TS27M4ACDT				27M4AC
TS27M4CN TS27M4ACN		DIP14	Tube	TS27M4CN TS27M4ACN
TS27M4CPT TS27M4ACPT		TSSOP14	Tape & reel	27M4C 27M4AC
TS27M4ID TS27M4IDT	-40°C, +125°C	SO-14	Tube or Tape & reel	27M4I
TS27M4AID TS27M4AIDT				27M4AI
TS27M4IN TS27M4AIN		DIP14	Tube	TS27M4IN TS27M4AIN
TS27M4IPT TS27M4AIPT		TSSOP14	Tape & reel	27M4I 27M4AI
TS27M4MD TS27M4MDT	-55°C, +125°C	SO-14	Tube or Tape & reel	27M4M
TS27M4AM TS27M4AMDT				27M4AM
TS27M4MN TS27M4AMN		DIP14	Tube	TS27M4MN TS27M4AMN
TS27M4MPT TS27M4AMPT		TSSOP14	Tape & reel	27M4M 27M4AM

6 Revision history

Table 7. Document revision history

Date	Revision	Changes
07-Jan-2001	1	Initial release.
08-Sep-2008	2	Removed TS27M4B version of device. Added R_{thja} , R_{thjc} , and ESD parameters in Table 1: Absolute maximum ratings (AMR) . Expanded Table 6: Order codes . Updated document format.

Please Read Carefully:

Information in this document is provided solely in connection with ST products. STMicroelectronics NV and its subsidiaries ("ST") reserve the right to make changes, corrections, modifications or improvements, to this document, and the products and services described herein at any time, without notice.

All ST products are sold pursuant to ST's terms and conditions of sale.

Purchasers are solely responsible for the choice, selection and use of the ST products and services described herein, and ST assumes no liability whatsoever relating to the choice, selection or use of the ST products and services described herein.

No license, express or implied, by estoppel or otherwise, to any intellectual property rights is granted under this document. If any part of this document refers to any third party products or services it shall not be deemed a license grant by ST for the use of such third party products or services, or any intellectual property contained therein or considered as a warranty covering the use in any manner whatsoever of such third party products or services or any intellectual property contained therein.

UNLESS OTHERWISE SET FORTH IN ST'S TERMS AND CONDITIONS OF SALE ST DISCLAIMS ANY EXPRESS OR IMPLIED WARRANTY WITH RESPECT TO THE USE AND/OR SALE OF ST PRODUCTS INCLUDING WITHOUT LIMITATION IMPLIED WARRANTIES OF MERCHANTABILITY, FITNESS FOR A PARTICULAR PURPOSE (AND THEIR EQUIVALENTS UNDER THE LAWS OF ANY JURISDICTION), OR INFRINGEMENT OF ANY PATENT, COPYRIGHT OR OTHER INTELLECTUAL PROPERTY RIGHT.

UNLESS EXPRESSLY APPROVED IN WRITING BY AN AUTHORIZED ST REPRESENTATIVE, ST PRODUCTS ARE NOT RECOMMENDED, AUTHORIZED OR WARRANTED FOR USE IN MILITARY, AIR CRAFT, SPACE, LIFE SAVING, OR LIFE SUSTAINING APPLICATIONS, NOR IN PRODUCTS OR SYSTEMS WHERE FAILURE OR MALFUNCTION MAY RESULT IN PERSONAL INJURY, DEATH, OR SEVERE PROPERTY OR ENVIRONMENTAL DAMAGE. ST PRODUCTS WHICH ARE NOT SPECIFIED AS "AUTOMOTIVE GRADE" MAY ONLY BE USED IN AUTOMOTIVE APPLICATIONS AT USER'S OWN RISK.

Resale of ST products with provisions different from the statements and/or technical features set forth in this document shall immediately void any warranty granted by ST for the ST product or service described herein and shall not create or extend in any manner whatsoever, any liability of ST.

ST and the ST logo are trademarks or registered trademarks of ST in various countries.

Information in this document supersedes and replaces all information previously supplied.

The ST logo is a registered trademark of STMicroelectronics. All other names are the property of their respective owners.

© 2008 STMicroelectronics - All rights reserved

STMicroelectronics group of companies

Australia - Belgium - Brazil - Canada - China - Czech Republic - Finland - France - Germany - Hong Kong - India - Israel - Italy - Japan - Malaysia - Malta - Morocco - Singapore - Spain - Sweden - Switzerland - United Kingdom - United States of America

www.st.com