

THIS DRAWING IS UNPUBLISHED.
 DIFFUSION RESTREINTE AMP
 © COPYRIGHT 19...
 RELEASED FOR PUBLICATION
 TOUTE LA DIFFUSION
 ALL RIGHTS RESERVED.
 TOUS DROITS RESERVES

LOC	DIST	REVISIONS				
P	LTR	REV	DESCRIPTION MODIFICATIONS	DATE	DWN DESS.	APVD APP.
	A		Coupe CC, 3.5/3.8 était 3.81	29NOV2004	GR	GR

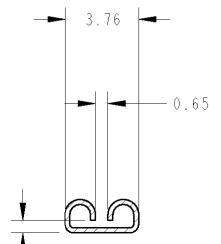

Entre-fer pour languette 2.8 x 0.5
 Gap for tab 2.8 x 0.5 series.

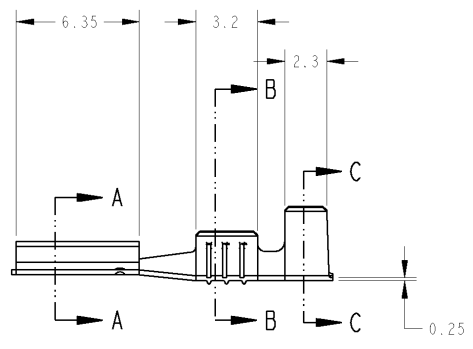
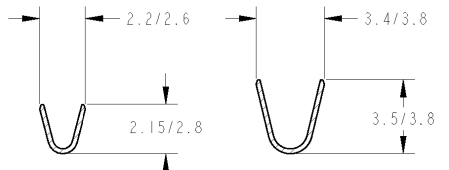

COUPE A-A COUPE B-B COUPE C-C

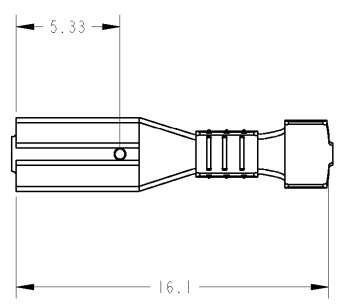

1 PRODUIT LIVRE EN BANDE. PAS 17.9±0.1.
 CONTINUOUS STRIP ON REEL, FEED 17.9±0.1.

1.5 2.5	0.3 1	0.5	NICKELE	ACIER	140813-2
DIA. ISOLANT	SECTION mm2	Ep. TAB	FINITION	MATIERE	REFERENCE

<small>THIS DRAWING IS A CONTROLLED DOCUMENT FOR AMP INCORPORATED. IT IS SUBJECT TO CHANGE AND THE CONTROLLING ENGINEERING ORGANIZATION SHOULD BE CONTACTED FOR THE LATEST REVISION. (ET PLAN EST UN DOCUMENT CONTROLÉ PAR AMP INCORPORATED. IL EST SUSCEPTIBLE D'ÊTRE REVISÉ. CONTACTER LE SERVICE TECHNOLOGIE D'AMP DE FRANCE POUR OBTENIR LA DERNIÈRE RÉVISION.)</small>		DWN /DESIGNE Gérard ROBERT CHK /VERIFIE Gérard ROBERT APVD /APPROUVE Yves PETRONILIN	AMP DE FRANCE 95301 PONTOISE
DIMENSIONS: mm	TOLERANCES UNLESS OTHERWISE SPECIFIED TOLERANCES NUM. SPEC. (FEES 3 SOIV. NB. DE DECIMALES): 0 PLC /DEC: ±. 1 PLC /DEC: ±0.5 2 PLC /DEC: ±0.13 3 PLC /DEC: ±0.013 4 PLC /DEC: ±0.0001 ANGLES ±	NAME TITRE .110 SERIES RECEPTACLE, FASTON	RESTRICTED TO RESERVE A
MATERIAL MATIERE VOIR TABLEAU	FINISH VOIR TABLEAU	PRODUCT SPEC SPEC. PRODUIT APPLICATION SPEC SPEC. APPLICATION 114-35000	WEIGHT MASSE APPROX. -
CUSTOMER DRAWING /PLAN CLIENT		SIZE FORMAT A3	CAGE CODE 00779
UNIFORMEMENT POUR REFERENCE		DRAWING NO N° PLAN 140813	SCALE ECHELLE 5:1
SHEET FEUILLE OF DE		REV A	

AMP 1470-19 REV 27JUN96

Prof/ENGINEER DRAWING