

4

3

2

1

THIS DRAWING IS UNPUBLISHED. RELEASED FOR PUBLICATION
 © COPYRIGHT - By - ALL RIGHTS RESERVED.

LOC	DIST	REVISIONS			
P	LTR	DESCRIPTION	DATE	DWN	APVD
AF	50	W3	REVISED PER ECO-11-005027	11MAR11	RK HMR

1 CONTINUOUS STRIP ON REELS.

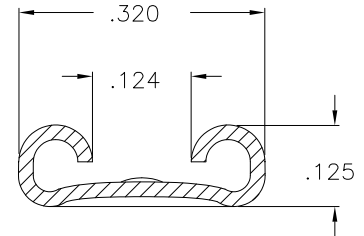
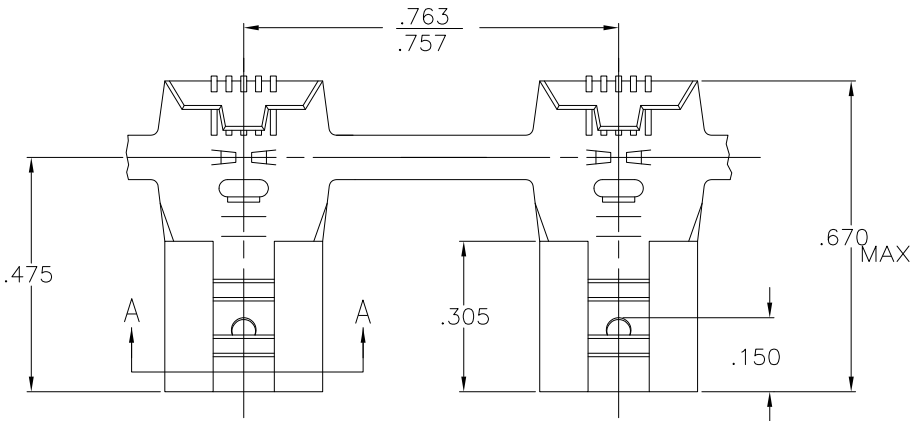

SECTION A-A

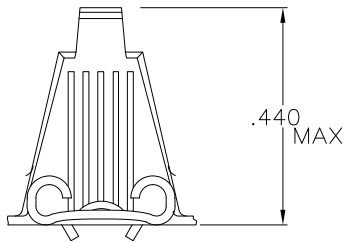

OBSOLETE

REV. REEL L.H.	12-10	.032 ±.001	TIN	.018 PHOS. BRONZE	62057-8
REV. REEL L.H.	12-10	.032 ±.001	SILVER	.018 PHOS. BRONZE	62057-7
REV. REEL L.H.	12-10	.032 ±.001		.018 BRASS	62057-6
	12-10	.032 ±.001	TIN	.018 PHOS. BRONZE	62057-5
REV. REEL L.H.	12-10	.032 ±.001	TIN	.018 4M BRASS	62057-4
	12-10	.032 ±.001	TIN	.018 4M BRASS	62057-3
	12-10	.032 ±.001	SILVER	.018 PHOS. BRONZE	62057-1
REELING	WIRE SIZE	TAB THK	FINISH	MATERIAL	PART NO.

THIS DRAWING IS A CONTROLLED DOCUMENT.		DWN	JR RUTH	2/3/86	 TE Connectivity
DIMENSIONS: INCHES		CHK	R KUZO	2/7/86	
TOLERANCES UNLESS OTHERWISE SPECIFIED:		APVD	C MEYERS	2/7/86	
0 PLC	± -	PRODUCT SPEC		NAME	.250 SERIES FLAG FASTON RECEPTACLE
1 PLC	± -	APPLICATION SPEC		SIZE	
2 PLC	± -	WEIGHT		A3	00779
3 PLC	± .015	MATERIAL		DRAWING NO	
4 PLC	± -	FINISH		C-62057	
ANGLES	± -	SEE TABLE		RESTRICTED TO	
SEE TABLE		CUSTOMER DRAWING		SCALE	1:1
				SHEET	1 of 1
				REV	W3